

Oksana Nadtoka

## NONLINEAR OPTICAL EFFECTS IN POLYMERIC AZOESTERS

Kyiv National Taras Shevchenko University  
64, Volodymyrska str., 01033 Kyiv, Ukraine; oksananadtoka@ukr.net

Received: March 31, 2010 / Accepted: May 20, 2010

© Nadtoka O., 2010

**Abstract.** The new photochromic polymers based on methacrylic azoesters were synthesized. The azobenzene side chains of obtained polymers contain different groups of both acceptor and donor nature as well as flexible alkyl spacer. The third order nonlinear optical susceptibilities ( $\chi^{(3)}$ ) of the studied solutions were measured by degenerating four wave mixing (DFWM) method. As a result, the enhancement of the molecular conjugation and the high NLO chromophore concentration in the molecular chain contribute much to heightening the third-order NLO effect. The electronic effect of the substituent on the azobenzol group and the push-pull electronic structure contributes much to enhancing the NLO property.

**Keywords:** azopolymer; polymethacrylate, third-order nonlinear optical property.

## 1. Introduction

Among the potential materials for reversible optical data storage, azobenzene side-chain polymers are especially promising due to their unique optical properties. Holograms of a very high diffraction efficiency and exceptional stability can be written (and erased) by the laser illumination in this material. Azobenzene polymers are interesting because they combine the properties of anisotropy with photoresponsive behavior that give rise to applications in such areas as LC displays, NLO materials and information storage devices, etc. [1-4].

Several inorganic, organic and polymeric materials have been found to be promising for nonlinear optics. Azobenzene based polymer systems play an important role in NLO studies and a large amount of data have been accumulated in this area.

Apart from NLO properties, an azobenzene system exhibits photoswitching properties, which make it suitable for variable kinds of applications. Azobenzenes exist in two isomeric forms (Fig. 1), the E (*trans*) and Z (*cis*) form, which can be recognized by differences in their UV absorption spectra [5, 6]. In principle, azobenzenes can

function as molecular switches by applying the light of different wavelengths to obtain varying amounts of *cis* and *trans* isomers, where the excess of one of the two isomers may be detected by a change in UV absorption spectra.

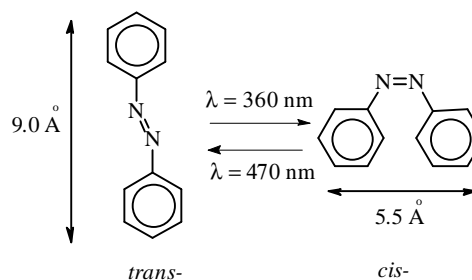

Fig. 1. Azobenzene isomerization

Photoanisotropic materials are widely investigated for optical storage and processing applications. The most promising of them seems to be side/main chain azopolymers because of the large value of the photoinduced birefringence in them. Azobenzene-containing polymers possess advantages for high optical nonlinearities due to a photoinduced *trans-cis* isomerization, molecular reorientation and nonlinear absorption and the disadvantage because of a micro-crystallinity which causes a light diffusion and is not suitable for a quality optical surface.

They are easy to prepare, process and fabricate in devices. Also, they can be readily integrated in semiconductor electronics and fiber-optic transmission lines. As a result, polymeric materials promise to make optoelectronic technologies more practical and widespread. They could make major impacts on telecommunications [7], as polymer based electrooptic modulators and switches have begun to enter the market and other applications are waiting for their turn.

In this paper a series of aromatic azobenzol compounds containing vinyl as monomers is presented. The azobenzene-containing side-chain polymers containing azo NLO chromophore in each side chain have been

synthesized *via* free radical polymerization. The obtained polymers have the repetitive azobenzene side chains as NLO chromophore in each chain unit, which causes the corresponding enhancement of the macroscopical NLO effect. Besides, the introduction of methacrylate chain from the methacryloyl chloride improves the solubility of azobenzol compounds, which provides much potentiality in filmforming. The influence of the push-pull electronic effect on the third-order NLO property of polymer by changing the substituents which have different electronic effect on the azobenzol group was studied on the other hand.

## 2. Experimental

### 2.1. Materials

The general structure of azopolymers is shown in Table 1. All chemicals were purchased from commercial

suppliers and used without further purification unless otherwise noted. Standard distillation procedures were applied. The structures of all the precursors and final products were confirmed by a liquid  $^1\text{H}$  NMR spectroscopy. All  $^1\text{H}$  NMR spectra were taken in  $\text{CDCl}_3$ . The obtained results were in a good agreement with the proposed structures. The phase transitions were studied by differential scanning calorimetry (DSC) using Perkin Elmer DSC-2 instrument equipped with IFA GmbH processor at the scan rate of 20 K/min. The calorimetry calibration was carried out according to well-known recent recommendations [8-10] using sapphire and quartz as standards.

### 2.2. Monomer Synthesis

The synthetic route for the target azomonomers (M1–M4) is shown in Scheme 1. The corresponding azochromophores were synthesized by general methods

Table 1

#### Objects of Investigation

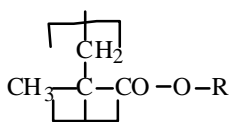

Code	R	$T_g$ , K	$I_{\max}$ , nm	$M_n$	$M_w$	$M_w/M_n$
P1		396	330	4500	5670	1.26
P2		433	360	5600	7800	1.39
P3		432	345	6500	8500	1.32
P4		385	360	3000	4200	1.38

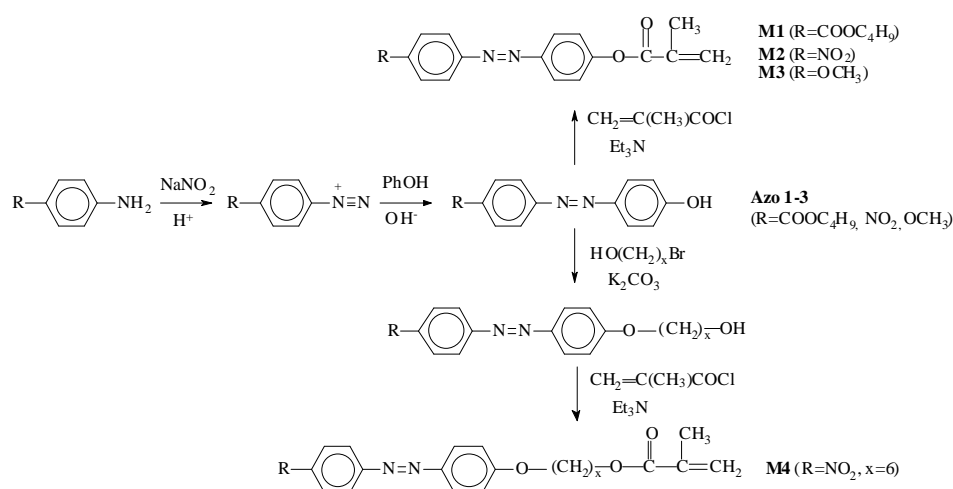

Scheme 1. Synthesis of methacrylic azomonomers

[11]. Then azocompound (0.06 mol) and triethylamine (9.0 ml; 0.06 mol) were dissolved in THF (200 ml). The solution was kept in an ice bath for 10 min. A solution of distilled methacryloyl chloride (6.0 ml, 0.06 mol) was added slowly to the above mixture. After the addition of methacryloyl chloride, the resulting mixture was stirred at room temperature overnight. Then the solution was poured into distilled water (1 l) and the obtained residue was filtered and air-dried. Recrystallization of monomers was carried out in ethanol.

#### 4-methacryloxy-4-butoxycarbonylazobenzene

**(M1):** Yellow crystals; yield 60 %; mp 336 K (by DSC). <sup>1</sup>H NMR (CDCl<sub>3</sub>), *d* (ppm): 7.89 (d, 2H, Ar), 7.73 (d, 2H, Ar), 7.93 (d, 2H, Ar), 6.94 (d, 2H, Ar), 6.34 (s, 1H, =CH<sub>2</sub>), 5.90 (s, 1H, =CH<sub>2</sub>), 2.10 (s, 3H, -CH<sub>3</sub>), 4.17 (m, 2H, CH<sub>2</sub>), 1.72 (m, 9H, C<sub>4</sub>H<sub>9</sub>). UV-vis (Ethanol) *I*<sub>max</sub>: 363, 495 nm. Elem. Anal. Calcd for C<sub>21</sub>H<sub>22</sub>O<sub>4</sub>N<sub>2</sub>: C, 67.38%; H, 5.88 %; N, 7.65 %. Found: C, 67.40%; H, 5.90 %; N, 7.61 %.

#### 4-methacryloxy-4-nitroazobenzene (M2):

Orange crystals; yield 85 %; mp 413 K (by DSC). <sup>1</sup>H NMR (CDCl<sub>3</sub>), *d* (ppm): 8.43 (d, 2H, Ar), 8.07 (d, 2H, Ar), 8.03 (d, 2H, Ar), 7.40 (d, 2H, Ar), 6.34 (s, 1H, =CH<sub>2</sub>), 5.91 (s, 1H, =CH<sub>2</sub>), 2.05 (s, 3H, -CH<sub>3</sub>). UV-vis (Ethanol) *I*<sub>max</sub>: 360, 480 nm. Elem. Anal. Calcd for C<sub>16</sub>H<sub>13</sub>O<sub>4</sub>N<sub>3</sub>: C, 61.74 %; H, 4.18 %; N, 13.50 %. Found: C, 61.70 %; H, 4.16 %; N, 13.52%.

#### 4-methacryloxy-4-methoxyazobenzene (M3):

Yellow crystals; yield 78 %; mp 393 K (by DSC). <sup>1</sup>H NMR (CDCl<sub>3</sub>), *d* (ppm): 8.21 (d, 2H, Ar), 8.01 (d, 2H, Ar), 7.83 (d, 2H, Ar), 7.33 (d, 2H, Ar), 6.35 (s, 1H, =CH<sub>2</sub>), 5.9 (s, 1H, =CH<sub>2</sub>), 4.11 (s, 3H, OCH<sub>3</sub>), 2.06 (s, 3H, CH<sub>3</sub>). UV-vis (Ethanol) *I*<sub>max</sub>: 345, 470 nm. Elem. Anal. Calcd for C<sub>17</sub>H<sub>16</sub>O<sub>3</sub>N<sub>2</sub>: C, 68.92 %; H, 5.4 %; N, 19.59 %. Found: C, 67 %; H, 5.45%; N, 19.52%.

#### 4-methacryloxyhexyloxy-4-nitroazobenzene

**(M4):** Orange crystals; yield 50 %; mp 345 K (by DSC). <sup>1</sup>H NMR (CDCl<sub>3</sub>), *d* (ppm): 8.02 (d, 2H, Ar), 8.34 (d, 2H, Ar), 7.68 (d, 2H, Ar), 7.10 (d, 2H, Ar), 6.30 (s, 1H, =CH<sub>2</sub>), 5.95 (s, 1H, =CH<sub>2</sub>), 2.20 (s, 3H, -CH<sub>3</sub>), 4.10 (m, 2H, ArOCH<sub>2</sub>), 3.9 (m, 2H, HOCH<sub>2</sub>), 1.72 (m, 4H, H<sub>2</sub>). UV-vis (Ethanol) *I*<sub>max</sub>: 365, 490 nm. Elem. Anal. Calcd for C<sub>22</sub>H<sub>25</sub>O<sub>5</sub>N<sub>3</sub>: C, 64.23 %; H, 6.08 %; N, 10.22 %. Found: C, 64.27 %; H, 6.06 %; N, 10.2%.

## 2.3. Polymerization

Polymers P1-P4 were synthesized by free-radical polymerization in toluene. The polymerization was carried out in 10 wt % toluene solution of monomer with AIBN as a free radical initiator (1 wt % of monomer) at 353 K over more than 10 h. Polymers were isolated from the reaction solution by precipitation into the excess of methanol followed by reprecipitation from toluene into methanol and then dried at 293 K overnight.

The obtained polymers were dissolved in dimethylformamide. The solutions of polymers were filtered through a 0.2 μm nylon filter before using.

## 2.4. Degenerating Four Wave Mixing Method

Nonlinear optical properties of azopolymers solutions (C = 12 g/l) were investigated using the DFWM method. The DFWM measurements were performed using Nd:YAG laser (Quantel Model YG472) working at 532 nm with 30 ps pulses duration and 1 Hz repetition rate [12]. In this experiment, three optical pulses (two pump beams *I*<sub>1</sub> and *I*<sub>2</sub> and a probe beam *I*<sub>3</sub>) were obtained by using two beam splitters (Fig. 2).

Carbon disulfide (CS<sub>2</sub>) was used as a reference material to calibrate the DFWM measurements (*c*<sup><3></sup> = 1.11 · 10<sup>-12</sup> esu). The polymers were contained in 2 mm thick quartz curves.

The DFWM reflectivity (*R*) was calculated from the propagation equation of the four beams in interaction and a linear and nonlinear absorption taken into account can be expressed as follows [13, 14]:

$$R = \frac{I_4(0)}{I_3(0)} = \frac{K^2}{\left[ q \coth(qL) - \frac{f}{2} \right]^2} \quad (1)$$

$$\text{with } q^2 = \left( \frac{f}{2} \right)^2 - K^2, \quad f = -a - 2b(I_1 + I_2)$$

$$\text{and } K^2 = \left( \frac{48p^3}{n^2cI} \right)^2 \left[ (c^{<3>})^2 + (c^{<3>})^2 \right] I_1 I_2 \quad (2)$$

where *a*, *b*, *L*, *I* and *n* are the linear absorption coefficient, the nonlinear absorption coefficient, the sample thickness, the laser wavelength and the linear refractive index, respectively.

We used the nonlinear transmission measurement to determine the two-photon absorption coefficient (*b*) that corresponds to the imaginary parts of the third order nonlinear optical susceptibility at 532 nm in the picosecond regime. We should notice that the investigated compounds exhibited only the linear absorption at the excitation wavelength.

Therefore, the only parameter that remains to be determined is the third order nonlinear optical susceptibility *c*<sup><3></sup>. Taking into account the linear and nonlinear absorption, the variation of the intensity of the pump waves along the *z*-axis may be expressed:

$$\frac{dI}{dz} = -(a + bI)I \quad (3)$$

The transmission can be calculated from the following equation:

$$T = \frac{I(L)}{I(0)} = \frac{a e^{(-aL)}}{a + bI(0)(1 - e^{-aL})} \quad (4)$$

The best fit of Eq. (4) to experimental data allows us to deduce *a* and *b* coefficients. Thus, knowing the

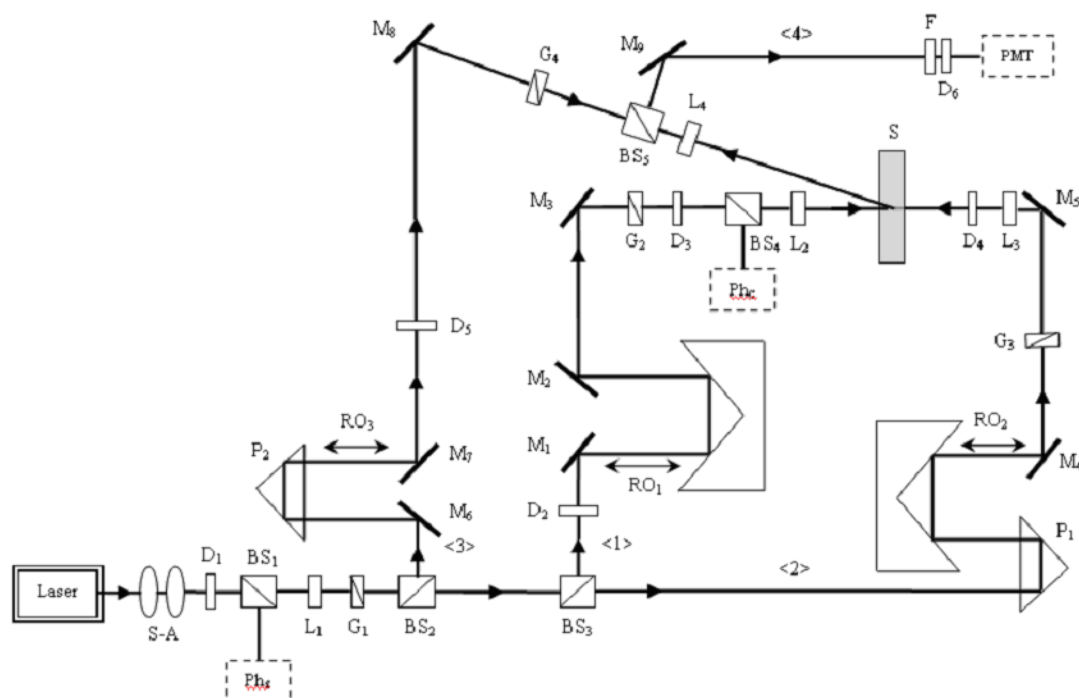

**Fig. 2.** Experimental set up of DFWM: S – sample, RO – delay lines, G – Glan prism, Ph<sub>s</sub> and Ph<sub>c</sub> – synchronization and control photodiodes, BS – beam-splitters, PMT – photomultiplier tube, <1> and <2> – pump waves, <3> – probe wave, <4> – fourth wave

analytic formula of the DFWM reflectivity  $R$  and measuring the  $I_4$  intensity, one can determine the absolute value of  $c^{<3>}$ .

The geometry of the DFWM experimental setup is presented in Fig. 2. As a source of radiation we used 532 nm from a Q-switched mode locked Quantel Nd:YAG laser of 30 ps duration, and a repetition frequency of 1 Hz. The first beam-splitter divides the beam to synchronize the acquisition from a fast photodiode. A Glan-Tompson prism (G) and a half-plate ( $\lambda/2$ ) allow to modify the intensity of the laser beam. The second beam-splitter reflects about 6 % of intensity (probe beam <3>). Non-reflected part of the beam goes to the next (third) beam splitter, which divides it in two pump beams <1> and <2>. Their intensities satisfy the relation  $I_1(z=0) = I_2(z=L)$ . The probe wave <3> is a weak probe beam ( $I_3 = 10^{-2} I_1$ ) which forms an angle of  $12^\circ$  with the direction of the two pump waves. The signal wave <4> is emitted in the opposite direction to the probe beam.

### 3. Results and Discussion

#### 3.1. Solubility of Side-Chain Polymers

The polymers are soluble in DMF and DMSO. They can even be dissolved in chloroform and dichlorethane. It shows the potential for film-forming and further application in devices. The monomers dissolve better than polymers

in alcohols and it is favorable for dissociation and purification of polymers.

#### 3.2. The Non-Linear Optical (NLO) Properties of Side-Chain Azopolymers

As shown in Table 2, all methacrylic azopolymers have high third-order NLO coefficient values for azo chromophores which are parts of them. In the result of polymerization, the obtained polymers in each chain unit have repetitive azobenzene side fragments which are NLO chromophores. Although the degree of polymerization is not very high, which is due to the steric effect of azobenzene chromophore in a polymer side chain, the macroscopical third-order NLO effect of polymer is enhanced by the non-linear superimposed NLO effect of the repetitive azobenzene chromophores in the same molecular chain of the polymer and some other effects such as photoelectric conjugation and selective orientation in the polymer chain.

Such NLO active substance as the Liquid Crystals (LC) and Cobalt Phthalocyanine (CoPc) which are known for their strong nonlinear optical properties [15] have been chosen for comparison.

The third-order nonlinear optical susceptibility ( $c^{<3>}$ ) of studied polymers is one order higher than for LC. So, in the molecular structure of azobenzol intermediate Azo2, the substituent on the one end of azobenzene is hydroxyl which is a donor group. When the electron

withdrawing group such as nitro group lies on the other end of azobenzene, the push-pull electronic structure was formed. The fluidity of electrons in the molecular chain is better and the intra-molecular charge transfer can be well performed, which is favourable to enhancing the NLO property [14]. But the methoxyl group on the other end of azobenzene (Azo3) cannot form the push-pull electronic structure with hydroxyl. After esterification with methacryloyl chloride, the conjugation in the molecule of azobenzol compound was enhanced and the energy gap between HOMO and LUMO is let up, which intensified the third-order NLO effect. Besides, after esterification, the substituent on the end of azobenzene is transformed from the hydroxyl group to the ester group (M3), which can form a push-pull electronic structure with the methoxyl group on the other end of azobenzene. Therefore, after polymerization the value of the third-order NLO coefficient of azobenzol-containing side-chain polymer P3 is much higher than that of azopolymers P1, P2 and P4.

*Table 2*  
**The third-order nonlinear optical coefficient ( $C^{<3>}$ ) of azopolymers**

Sample	The third-order NLO coefficient ( $C_{DFWM}^{<3>}$ ), $\times 10^{-13}$ esu
DMF	1.38
P1	2.26
P2	3.03
P3	9.15
P4	3.71
CoPc <sup>[a]</sup>	25.2
LC <sup>[b]</sup>	0.3

Note: <sup>a</sup>cobalt phthalocyanine (CoPc); <sup>b</sup>liquid crystal (LC) for comparison

In the case of CoPc, the value of the third-order nonlinear optical susceptibility ( $C^{<3>}$ ) is higher than that for azopolymers. Nevertheless in contrast to inorganic compound these polymers have a number of valuable advantages. First of all they possess excellent film-forming and plastic properties and they are chemically inert as well. Polymer materials might provide the systems with unique possibilities and higher flexibilities in comparison with inorganic materials because of the relatively easy way to penetrate organic polymeric materials into practical devices (microdevices such as micromachines and microelectronic mechanical systems, *etc.*).

## 4. Conclusions

A new series of aromatic azobenzol monomers containing vinyl has been synthesized. *Via* free radical

polymerization of these monomers azobenzene-containing side-chain polymers containing azo NLO chromophore in each side chain were obtained. Azopolymers have high third-order NLO coefficients and the value increases with the increase of molecular conjugation. The electronic effect of substituents in the azobenzol group also influences the third-order NLO properties significantly. When the push-pull electronic structure forms, the electron in the molecular chain flows freely and the energy gap of the conjugate system decreases, which contributes much to enhancing the NLO property of polymers. Excellent film-forming of polymers offers great promise for practical device applications.

## Acknowledgements

The author is greatly thankful to Dr. O. Krupka for a given technical opportunity to carry out researches.

## References

- [1] Sutherland R.: Handbook of Nonlinear Optics. Marcer Dekker, New York 1996.
- [2] Kumar G.: Azo Functional Polymers: Functional Group Approach in Macromolecular Design. Technomic Publication, Lancaster 1992.
- [3] Demus D., Goodby J., Gray G. *et al.*: Handbook of Liquid Crystals. Wiley-VCH, New York 1998.
- [4] Sekkat Z. and Knoll W.: Photoreactive Organic Thin Films. Academic Press, Amsterdam 2002.
- [5] Durr H. and Laurent H.: Photochromism: molecules and systems in studies in organic chemistry. Elsevier, Amsterdam 1990.
- [6] Epstov A.: Organic Photochromes, V. 3. Plenum Press, New York 1971.
- [7] Meredith G., Van Dusen J. and Williams D.: Macromolecules, 1982, **15**, 1385.
- [8] Wunderlich B., Boller A., Okazaki I. and Ishikiriyama K.: Thermochim. Acta, 1997, **304/305**, 125.
- [9] Ribeiro M. and Grolier J.-P.: Thermal Anal. & Calorimetry, 1999, **57**, 253.
- [10] Wunderlich B.: Prog. Polymer Sci. 2003, **28**, 383.
- [11] Vorozhtcov N.: Osnovy Synteza Promezhutochnykh Produktov i Krasyteley. Moskwa 1955.
- [12] Sahraoui B. and Rivoire G.: Opt. Comm., 1997, **138**, 109.
- [13] Smokal V., Czapllicki R., Derkowska B. *et al.*: Synth. Met., 2007, **157**, 708.
- [14] Li N., Lu J., Xu Q. and Wang L.: Opt. Mat., 2006 **28**, 1412.
- [15] Yaroshchuk O., Sergan T., Kelly J. and Gerus I.: Jpn. J. Appl. Phys., 2002, **41**, 275.

## НЕЛІНІЙНО ОПТИЧНІ ВЛАСТИВОСТІ В ПОЛІАЗОЕСТЕРАХ

*Анотація.* Синтезовані нові фотохромні полімери на основі метакрилових естерів. Показано, що бічні азобензольні ланки отриманих полімерів містять різні групи донорно-

акцепторної природи, а також гнучкий алкільний спейсер. Методом змішування чотирьох вироджених хвиль (ЗЧВХ) виміряно нелінійно-оптичну сприйнятливості третього порядку ( $\chi^{(3)}$ ) досліджуваних розчинів. Показано, що зростання внутрішньо-молекулярного спряження та висока концентрація НЛО хромофорів у макромолекулярному ланцюгу впливає на

посилення НЛО ефекту третього порядку. Встановлено, що електронний ефект замісника в азобензольній групі та пушпульна електронна структура значно покращують НЛО властивості.

**Ключові слова:** азополімер, поліметакрилат, нелінійно оптичні властивості третього порядку.