

ON CRACK DEVELOPMENT IN REINFORCED SLAB OF STEEL CONCRETE COMPOSITE BEAMS

© Flaga K., Furtak K., 2010

Надано налігичні і графічні розв'язки, які оцінюють ефект напружень усадження, що ініціюють тріщиноутворення в армованій плиті сталобетонних складених балок. Доведено, що це напруження впливає на місце походження тріщин – низу плити або верху, де деформації і напруження від зовнішнього навантаження найістотніші.

Ключові слова: напруження усадження, тріщиноутворення, складені балки, плита.

Analytical and graphic solutions enabling an evaluation of the effect of shrinkage strain on initiation of cracking in reinforced slab of steel-concrete composite beams have been given. It was proved that this strain affects the place of crack origin, the slab bottom or top, where strains and stress from external loads are most significant.

Keywords: shrinkage strain, cracking, composite beams, slab.

1. Introduction. The problem of cracking of reinforced concrete slabs in steel-concrete composite beams is not new. However, it has usually been treated marginally with the main focus on the load capacity of elements [4, 5]. It was reflected also in norms [6,7] and in the proposal of a new norm for composite structure design, based on EC 4 [2].

Still less attention has been paid to the effect of thermal stress induced by cement hydration heat and changes in ambient temperature [1, 3, 4]. Slightly more attention has been paid to the influence of concrete shrinkage on slab cracking [4].

One of important factors of composite beams thermal resistance to reinforced concrete slab cracking is the so-called resistance coefficient $b = A_s / A_c$ defined as the ratio between steel girder section area A_s and concrete slab section area A_c . Obviously, it is a proof parameter because in actual reality neither the shape of the steel girder nor mutual relationship between the fields of the booms of this girder and web are unimportant.

On the basis of [1, 3, 4] it can be assumed that when $b \leq 0,5$, thermal stress from cement hydration heat do not have any significant effect. The more so that they occur at the initial stage of concrete curing, when the value of its modulus of elasticity is much lower than the one adopted in static-strength calculations.

From the point of view of composite beam state of effort what matters more is residual stress from shrinkage strain. It develops at the stage of concrete reaching determinative (generally 28-day) compressive and tensile strengths as well as a value of the modulus of elasticity. It can affect the stress and strain state in composite girders and influence slab cracking [4].

The aim of the paper is to present an analysis of the influence of shrinkage strain on the causes and sequence of crack initiation in a reinforced slab integrated with a steel girder. The analysis deals with the initial stage of crack forming influenced by concrete shrinkage and external loads.

2. Strains and stresses in reinforced slab. General remarks. In the analysis of strain and stress in a reinforced slab integrated with a steel girder it was assumed that the whole of it is in the tension zone. This means that the neutral axis of the composite girder runs in the steel part. Moreover, linear changeability of the stresses in concrete and the validity of the principle of plane section were assumed (fig.1).

It was assumed that the ratio between concrete tensile strength and its modulus of elasticity is constant over the given time period. Creep was disregarded, since the time between load operation to first cracks initiation is short.

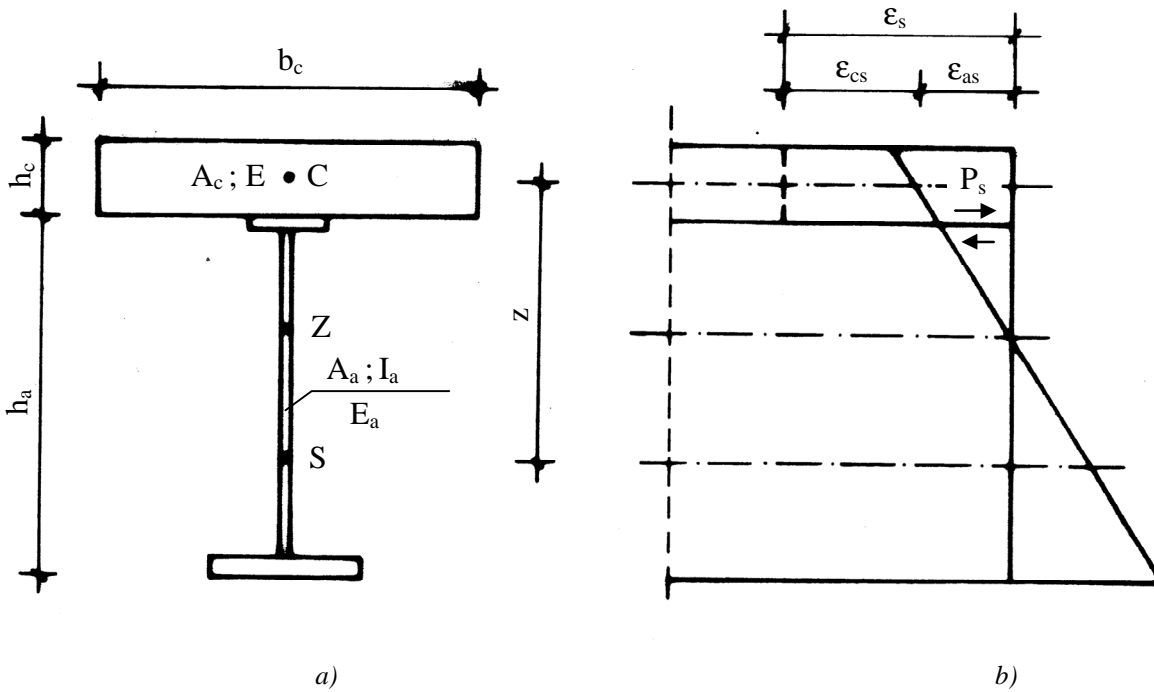

Fig. 1. Denotation used in: a) cross section, b) concrete shrinkage induced longitudinal strain

- **Shrinkage strains and stresses.** Due to concrete shrinkage strain and steel girder resistance the delaminating force P_s appears in the composition plane (cf. fig.1). Its operation is eccentric relative to center line of gravity of the steel girder and reinforced slab, analysed separately.

Since the tensile force P_s affecting the slab operates on the edge of the rectangular section, the strain it causes is described by equations (fig. 2):

- for extreme filament

$$e_{cgs} = - \frac{2P_s}{E_c b_c h_c}, \quad (1)$$

- for filament in the composition plane

$$e_{cds} = \frac{4P_s}{E_c b_c h_c}, \quad (2)$$

where E_c — modulus of elasticity of concrete; b_c —width of slab; h_c – thickness of slab.

In a general format it can be written:

$$P_s = P_s(t) = N_c(t) = N_a(t) \quad (3)$$

where $N_c(t)$ and $N_a(t)$ are forces acting on the reinforced slab and steel girder, respectively, applied in the composition plane, dependent on time t .

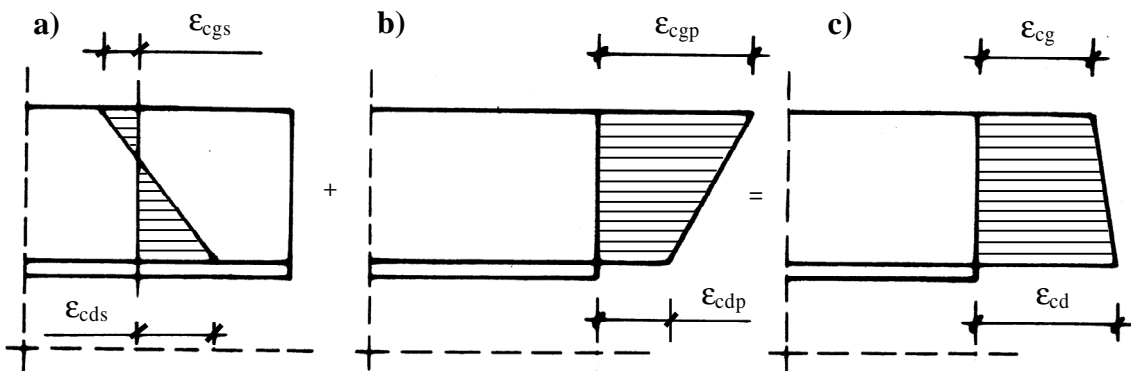

Fig. 2. Strains in reinforced concrete: a) from concrete shrinkage, b) from external loads, c) summary strain

On the basis of [4] it was assumed that (cf. fig. 2):

$$N_c(t) = e_{cs}(t) E_c(t) A_c, \quad (4)$$

$$N_a = \frac{e_{as}(t)}{d_a}, \quad (5)$$

$$e_{cs}(t) + e_{as}(t) = e_s(t), \quad (6)$$

where:

- $\varepsilon_s(t)$ - free shrinkage strain,
- $\varepsilon_{as}(t)$ - proof strain of steel girder on the neutral axis of reinforced slab,
- $\varepsilon_{cs}(t)$ - strain in concrete caused by steel girder resistance to concrete shrinkage,
- δ_a - generalised factor of stiffness of steel girder

$$d_a = \frac{1}{E_a A_a} + \frac{z^2}{E_a I_a}, \quad (7)$$

- $E_c(t)$ - modulus of elasticity of concrete
- A_c - cross section of reinforced slab,
- z - distance between centroids steel girder and reinforced slab,
- E_a - modulus of elasticity of steel,
- A_a - cross section of steel girder,
- I_a - moment of inertia of steel girder relative to its central axis.

After transformations we obtain:

$$e_{as}(t) = \frac{d_a}{d_a + d_c} e_s(t), \quad (8)$$

$$e_{cs}(t) = \frac{d_a}{d_a + d_c} e_s(t), \quad (9)$$

where:

- δ_c - generalised coefficient of stiffness of reinforced slab

$$\delta_c = \frac{1}{E_c A_c}, \quad (10)$$

- A_c - reinforced slab section.

Using equations (2) ÷ (4) we obtain:

$$e_{cds}(t) = \frac{4N_c(t)}{E_c(t)A_c} = \frac{4d_c}{d_a + d_c} e_s(t), \quad (11)$$

$$e_{cgs}(t) = \frac{2d_c}{d_a + d_c} e_s(t). \quad (12)$$

• **Strains and stresses from external loads.** At full integration and applying the composite structure technical theory the values of external load induced strains are:

- for extreme filament

$$e_{cgp} = \frac{M}{W_{cg} E_c} = \frac{M}{E_c I_{zc}} x, \quad (13)$$

- for filament in composition plane

$$e_{cdp} = \frac{M}{W_{cd} E_c} = \frac{M}{E_c I_{zc}} (x - h_c), \quad (14)$$

where:

- I_{zc} - moment of inertia of composite section relative to neutral axis, reduced to concrete section

$$I_{zc} = nI_a + I_c + nA_a a_a^2 + A_c a_c^2, \quad (15)$$

$$n = Ea/Ec, \quad (16)$$

- x - distance between extreme filaments under tension from composite girder centroid,
- h_c - reinforced slab thickness,
- a_a - distance between reinforced slab centroid and girder neutral axis,
- a_c - distance between steel girder centroid and composite girder neutral axis,
- I_c - moment of inertia of reinforced slab relative to its neutral axis,
- W_{cg} - strength factor for extreme filament of reinforced slab,
- W_{cd} - strength factor for reinforced slab filaments at the composition plane level.

So we get:

$$E_c I_{zc} = B_{zc} = E_a I_a + E_c I_c + E_a A_a a_a^2 + E_c A_c a_c^2. \quad (17)$$

After substituting (17) in (13) and (14) we obtain:

$$e_{cgp} = \frac{M}{B_{zc}} x, \quad (18)$$

$$e_{cdp} = \frac{M}{B_{zc}} (x - h_c). \quad (19)$$

• **Total strains.** Total strains are a sum of concrete shrinkage and external load. It is defined by equations:

- for extreme filaments

$$e_{cg} = \frac{2d_c}{d_a + d_c} e_s(t) + \frac{M}{B_{zc}} x, \quad (20)$$

- for filaments in composition plane

$$e_{cd} = \frac{4d_c}{d_c + d_c} e_s(t) + \frac{M}{B_{zc}} (x - h_c). \quad (21)$$

3. Evaluation of cracking state

• **Concrete shrinkage induced cracking.** Concrete shrinkage induced cracking takes place when:

$$e_{cds}(t) = \frac{4N_c(t)}{E_{c(t)}A_c} > e_{ct,lim}. \quad (22)$$

After substituting (4) and (10) to (26) we obtain:

$$e_{cds}(t) = \frac{4d_c}{d_c + d_c} e_s(t) > e_{ct,lim}, \quad (23)$$

Hence:

$$\frac{e_{ct,lim}}{e_s(t)} < \frac{4d_c}{d_a + d_c}. \quad (24)$$

The equation describing concrete limit elongation ability can be written as [4]:

$$e_{ct,lim} = \frac{f_{ctm}}{E_c} \eta_f, \quad (25)$$

$$h_f = 1 + \frac{0,08 r_r}{f^{1,5}}, \quad (26)$$

where:

f_{ctm} - mean concrete tensile strength, MPa,

E_{ct} - concrete modulus of tensile elasticity assumed to be equal to concrete compressive elasticity E_c , [MPa],

ρ_r - degree of reinforcement referred to effective cross sectional area of concrete under tension,

Φ - diameter of reinforcement bars [m].

Taking into account (25) and (26) inequality (24) can be transformed into:

$$\frac{f_{ctm}}{E_c e_s(t)} h_f < \frac{4d_c}{d_a + d_c}, \quad (27)$$

$$h_c(t) h_f < \frac{4d_c}{d_a + d_c}, \quad (28)$$

$$h_c(t) = \frac{f_{ctm}}{E_c e_s(t)} \quad (29)$$

where:

Reinforced slab cracking induced by concrete shrinkage will take place when:

$$\omega = \frac{h_c(t) h_f}{4d_c} (d_a + d_c) < 1, \quad (30)$$

or

$$\omega = \frac{h_c(t) h_f}{4} (1 + d) < 1, \quad (31)$$

or

$$\omega = \frac{h_c(t) h_f}{4b_0} (1 + b_0) < 1, \quad (32)$$

where b_0 is generalised resistance coefficient

$$b_0 = \frac{1}{d} = \frac{d_c}{d_a}. \quad (33)$$

• **Cracking induced by concrete shrinkage and external loads combined.** The analysis of equations describing e_{cg} i e_{cd} points to the fact that it is impossible to state unequivocally which of the strains will reach $e_{ct,lim}$ sooner. It depends on shrinkage strain and geometric characteristics of the section, including the generalised coefficient of resistance b_0 as well as class of concrete and slab reinforcement.

What may be an indicator is in this case the slope of strain curve in the slab induced by concrete shrinkage and external loads. In the former case we obtain:

$$k_s = \frac{e_{cds} - e_{cgs}}{h_c} = \frac{6d_c}{(d_a + d_c)} e_s(t), \quad (34)$$

in the latter case:

$$k_p = \frac{e_{cg} - e_{cd}}{h_c} = \frac{M}{B_{zc}}. \quad (35)$$

The resultant slope of strain curve can be derived from equation:

$$k = k_s / k_p = \frac{6d_c B_{zc}}{(d_a + d_c) h_c} \frac{e_s(t)}{M}. \quad (36)$$

If $k > 1$, the slab will start cracking on the steel girder side, while if $k < 1$ from the extreme filaments. At $k = 1$ at the time of cracking the slab will be under axial tension.

If $\varepsilon_{cds} < \varepsilon_{ct,lim}$, shrinkage cracks will not occur. Then external load induced strain that will cause slab cracking is:

$$\Delta e_{ct}(t) = e_{ct,lim} - e_{cds}(t) = e_{ct,lim} - \frac{4d_c}{d_a + d_c} e_s(t), \quad (37)$$

$$\Delta e_{ct}(t) = e_{ct,lim} - \frac{4b_0}{1 + b_0} e_s(t). \quad (38)$$

or

Dividing both sides of equation (37) by $e_{ct,lim}$ we obtain:

$$I = \frac{\Delta e_{ct}(t)}{e_{ct,lim}} = 1 - \frac{4b_0}{(1+b_0)} \frac{e_s(t)}{e_{ct,lim}} = 1 - \frac{4b_0}{1+b_0} h_s, \quad (39)$$

$$h_s = \frac{e_s(t)}{e_{ct,lim}} \quad (40)$$

where:

4. Analysis of solutions. The results of analysis of the effect of particular parameters on the state of cracking have been shown in a graphic form in subsequent figures 3 ÷ 7. Figure 3 illustrates the effect of the degree of reinforcement r_r and reinforcement bars diameter f on concrete limit elongability $e_{ct,lim}$.

What has been adopted as the effect of this impact the value of coefficient h_f , after equation (26).

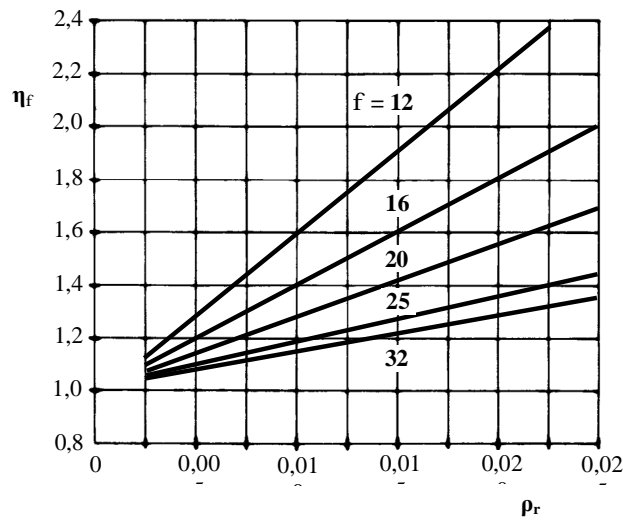

Fig. 3. Effect of reinforcement degree r_r and diameter of reinforcement bars f on concrete limit elongability

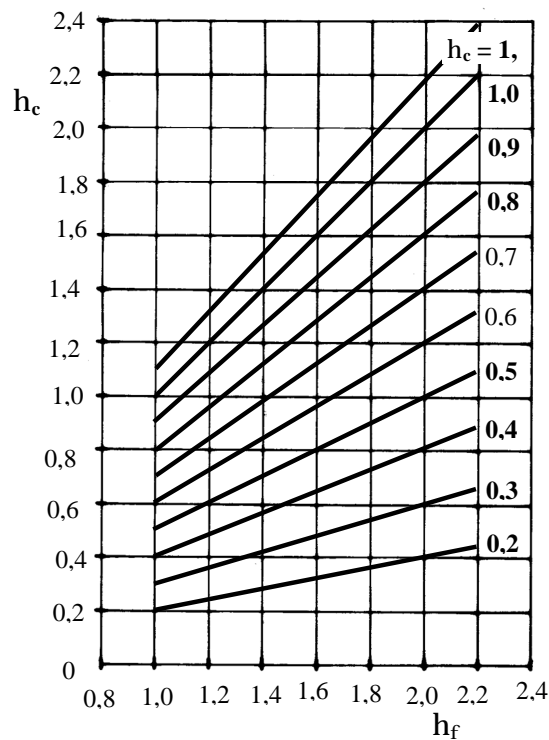

Fig. 4. Combined effect of reinforcement bar diameter f and concrete shrinkage e_s on coefficient $\eta_c f$

The combined effect of reinforcement bar diameter and concrete strength has been shown in fig. 4. As input parameters coefficients h_f and h_c , described by equations (26) and (28), have been adopted. A wide range of the values of these coefficients has been taken into account. This range, however, lies within realistic boundaries, considering the real steel-concrete composite elements.

Figure 5 illustrates the effect of the generalised resistance coefficient b_0 . Parameters (f , e_s , f_{cm} , E_c) discussed earlier refer to the interacting reinforced slab, whereas coefficient b_0 covers also the steel girder, thus including the total composite section. If at the design stage coefficient k in fig. 5 is lower than one, shrinkage cracking will occur (with no contribution from external loads). They will first appear on the bottom surface of the slab (on the composition surface side).

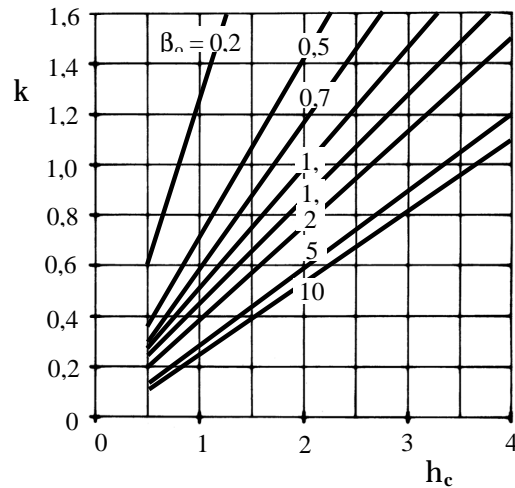

Fig. 5. Effect of generalised resistance coefficient b_0 on slab strain curve slope

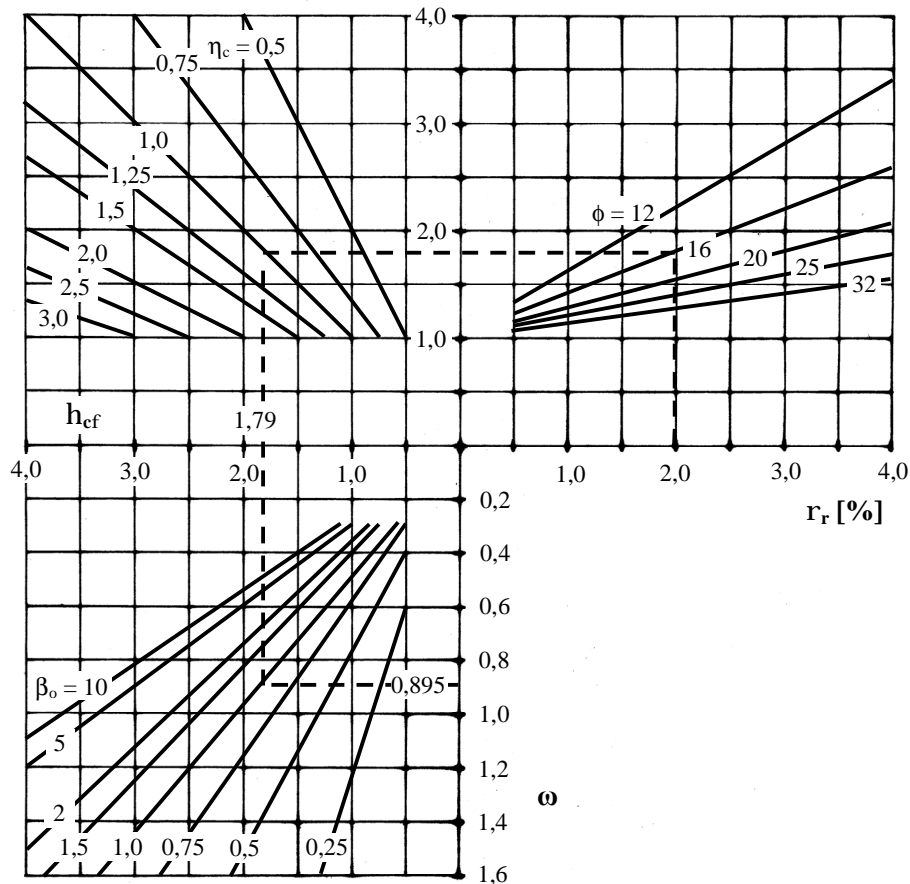

Fig. 6. Chart for evaluation of shrinkage cracking initiation possibility

It is easy to evaluate the real possibility of shrinkage cracking initiation using fig. 6. It covers the effect of all the parameters affecting the state of stress and strain as well as concrete elongability, and thus any possibility of occurrence of shrinkage cracks.

The value $\omega = 0,875 < 1,0$ for $r_r = 0,02$, $f = 16$ mm, $h_c = 0,5$ i $b_0 = 1,0$, shown in fig. 6, indicates that reinforced slab cracking will be induced by concrete shrinkage, even before external load is applied. If $\omega \geq 1,0$, the slab may crack under the effect of additional strain $\Delta\varepsilon_{ct}(t)$. The analysis in this aspect has been shown in fig. 7. The negative values of I indicate shrinkage cracking occurrence before external load is applied.

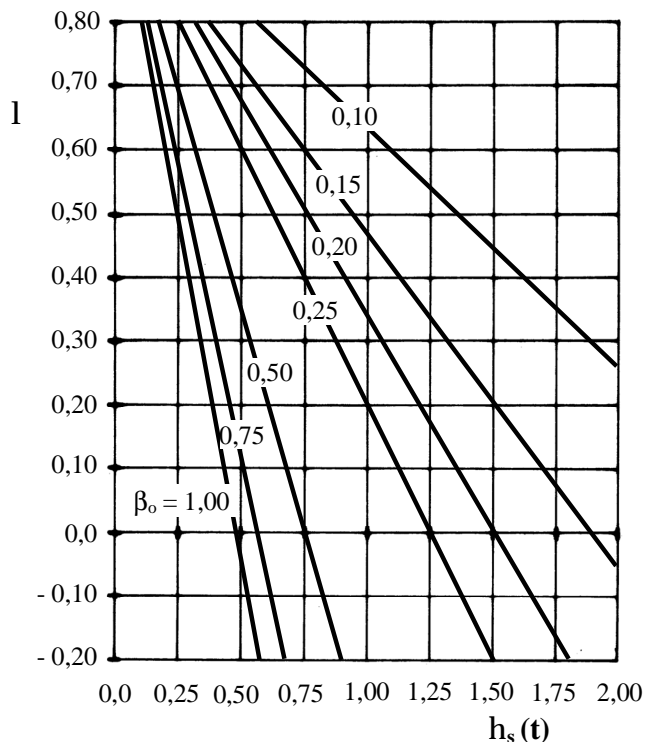

Fig. 7. Dependence of coefficient $\lambda(t)$ on generalised resistance coefficient

5. Final remarks. The analysis results presented enable a statement that shrinkage cracking may occur in the reinforced slab of steel-concrete composite girder before an external load is applied. What decides of crack initiation is reinforcement degree and reinforcement bar diameter together with concrete strength as well as the so-called generalised resistance coefficient b_0 , which characterises the interrelationships and stiffness of the steel girder and reinforced slab.

Concrete elongation due to its shrinkage is more significant in the bottom filament (in case of a steel girder). This means that shrinkage cracks can start at the bottom of the slab. This phenomenon was observed in, for example, the investigations described in [5].

In real steel-concrete composite elements the value of coefficient β_0 is in a wide range. However, it can be assumed that for average values of other parameters shrinkage cracks will not appear for $\beta_0 < 0,25$. Their initiation can be restricted by sensible reinforcement of the slab (diameter ϕ and reinforcement percentage ρ_r).

The curves shown in figures 3 ÷ 7 can help to evaluate fast (but approximately) the possibility of shrinkage cracks initiation. They can also be helpful in designing steel-concrete composite beams.

1. Ducret J.M., Lenet J.-P. *Effects of Concrete Hydration on Composite Bridges*. Conference Report: Composite Construction o Conventional and Innovative. Innsbruck. September, 1997. 2. Eurocode 4. *Design of Composite Steel and Concrete Structures: Part 1-1. General Rules and Rules for Buildings; Part 2. Bridges*. 3. Flaga K., Pańtak M. *Ryzyko zarysowania płyt pomostów konstrukcji zespolonych betonowo-stalowych*. „Inżynieria i Budownictwo”, nr 8/2003. [3] (Risk of cracking of deck slabs of steel-

concrete composite structures. Engineering and building) 4. Furtak K. *Mosty zespolone. (Composite bridges)* PWN, Warszawa-Kraków 1999. 5. Jarek B. *Zarysowanie płyty żelbetowej w belkach zespolonych typu stal-beton: Praca doktorska. Politechnika Krakowska, 2004. (Cracking of reinforced slab in composite steel-concrete beams. PhD dissertation. Cracow University of Technology), 2004.* 6. PN-82/B-03300. *Composite steel-concrete structures. Structural analysis and design. Composite squat beams.* 7. PN-86/B-03301. *Composite steel-concrete structures. Structural analysis and design. Composite slender beams.*

M. Łagoda

Lublin University of Technology

STRENGTHENING OF CONCRETE ELEMENTS BY PRESTRESSED COMPOSITE STRIPS

© Łagoda M., 2010

Представлено результати досліджень з метою демонстрації можливості і практичних переваг, що походять від додатка напруженої композитної смуги (вуглецеве армоване полімерне волокно), щоб підсилити бетонні конструкції. Розповсюдження напружень зрізу у клейовому з'єднанні було визначено на підставі теоретичного аналізу рівноважного стану. Запроектовано систему напруження смуги CFRP і зміцнення напружених балок. Балку перевірено під статичними і динамічними навантаженнями. Наведено результати випробувань і висновки, що ґрунтуються на них.

Ключові слова: CFRP, бетонні конструкції, напруження зрізу, напружені балки.

The paper presents the results of research aiming at exposing the possibility and practical advantages resulting from the application of stressed composite strip (Carbon Fibre Reinforced Polymer) to strengthen concrete structures. The distribution of shear stress in the glue joint was determined on the basis of theoretical analysis of equilibrium state. This knowledge allowed the system of stressing CFRP strip and strengthening the prestressed girder to be designed. The girder was tested under static and dynamic loads. The paper presents the results of tests and conclusions based on them.

Keywords: CFRP, concrete structures, shear stress, prestressed girder.

1. Introduction. In bridge strengthening, high tensile strength of composite strip CFRP was utilized in small degree [1, 2, 3] till now. Composite strips are characteristic by very large range of linear strain, reaching the value of 1.8%. The allowable extension of the glued composite element is the decisive parameter to the way of its utilization and cost effective application of this type of reinforcement. Hence the endeavours to apply composite strip in the stressed state [4, 5, 6,7].

Strip pre-tensioning allows taking fuller advantage of its capacity and the resulting increase of economic effectiveness of the reinforcement [8, 9, 10, 11]. Pre-tensioned composite strip reinforced with carbon fibre (CFRP) gives new possibilities of strengthening existing structures. Thanks to stressing, the bonded CFRP strip takes an active part in carrying dead loads imposed on structure and causes stress reduction in the inner reinforcement [12, 13, 14]. The anchorages take an important part of the delaminating force and diminish radically shear stresses in the glued joint, particularly at strip ends [15, 16, 17]. Proper design and effective use of stressed composite strip requires analytic and empirical investigation of inner force distribution (stresses) in the strengthened structure and especially shear forces prevailing in the glued joint.