

**O. S. Ivashchuk**

Lviv Polytechnic National University,  
Department of Chemical Engineering

## SIMULATION OF THE CAVITATION PROCESS IN THE LIQUID MEDIUMS

© *Ivashchuk O. S., 2018*

The article is devoted to computer modeling of the process of cavitation in liquid mediums. The experimental researches of the regularities of the cavitation process was conducted, dependences of changes in the parameters of the process efficiency on the concentration of the solution and the frequency of vibration are shown. A solid– state model of a laboratory vibration resonance electromagnetic cavitator in SolidWorks 2016 Educational Edition software system was created. Based on the modeling of the cavitation process, the main hydrodynamic parameters are defined: temperature change, static pressure and flow velocity in the laboratory chamber.

**Key words:** cavitation, simulation.

**О. С. Іващук**

## КОМП'ЮТЕРНЕ МОДЕЛЮВАННЯ ПРОЦЕСУ КАВІТАЦІЇ В РІДКИХ СЕРЕДОВИЩАХ

© *Іващук О. С., 2018*

Розглянуто комп'ютерне моделювання процесу кавітації у рідких середовищах. Виконано експериментальні дослідження закономірностей процесу кавітації модельних розчинів, наведено залежності зміни параметрів ефективності процесу від концентрації розчину та частоти вібрації. Створено твердотільну модель лабораторного віброрезонансного електромагнітного кавітатора у програмному комплексі SolidWorks 2016 Educational Edition. На основі моделювання процесу кавітації визначено основні гідродинамічні параметри: зміну температури, статичного тиску та швидкості потоку у робочій камері лабораторної установки.

**Ключові слова:** кавітація, комп'ютерне моделювання.

**Introduction.** Chemical technology in recent years widely uses cavitation processes for a variety of purposes and at different scales. The cavitation process is based on the multi-pointlocal reduction in fluid pressure resulting from an increase in the flow rate, the passage of an acoustic wave of high intensity, or for other reasons. When moving to a fluid in a region with higher pressure, the cavitation bubbles immitate , while isolating the shock wave [1–3].

Cavitation is the process of formation of cavities in drip fluids filled with gas, vapor or a mixture of them (so-called cavitation bubbles or cavities) [4–6]. Bubbles of cavitation are formed in those places where the liquid pressure reaches a certain critical value  $P_{cr}$  (for a real liquid  $P_{cr}$  is approximately equal to the pressure of saturated vapor of this liquid at a given temperature). If the pressure drop occurs due to large local velocities in the fluid flow, then the cavitation is called hydrodynamic. The sharp collapse of the gen

erated gas cavities creates a very sharp sudden increase in local pressure. The value of the pressure drop in such zones can reach several thousand atmospheres.

This process can be both positive and negative, so it is very important to establish a balance when making engineering decisions and take into account the possible destructive effects of this process. However, using this process in a positive way is quite effective.

Cavitation is a rather complex physical process and arises only under certain conditions and can not move through the flow. Therefore, preliminary analysis and modeling of hydrodynamic systems can greatly simplify the process of designing devices and predict probable processes. Using computer simulation tools it is possible to achieve and predict such individual processes, which are simply unrealistic to calculate under the usual calculation. With the help of automated design and calculation systems, it is possible to significantly reduce the cost of creating technical and design documentation, reduce the time of engineering calculations and eliminate the possibility of human-factor errors.

Computer simulation brings to life the possibilities of design, development and testing, which in real conditions are impossible. “Virtual” experiments can potentially be carried out several times, with the ease of changing the parameters that are often impossible in reality or costly. There are also many universal physical models that can be used to model entirely different objects.

However, it should be noted that computer simulation can not be an independent basis for detecting new phenomena, because any discoveries of this type require experimental confirmation. The purpose of the research was to analyse and research the technical features of the process of cavitation in liquid media; conducting experimental researches and setting process parameters; engineering analysis of the results obtained using computer simulation tools in the SolidWorks 2016 Educational Edition software suite.

**The methodology of experimental research.** The experiments were carried out using a laboratory installation of an electromagnetic vibration cavitator (Figure 1) [7].

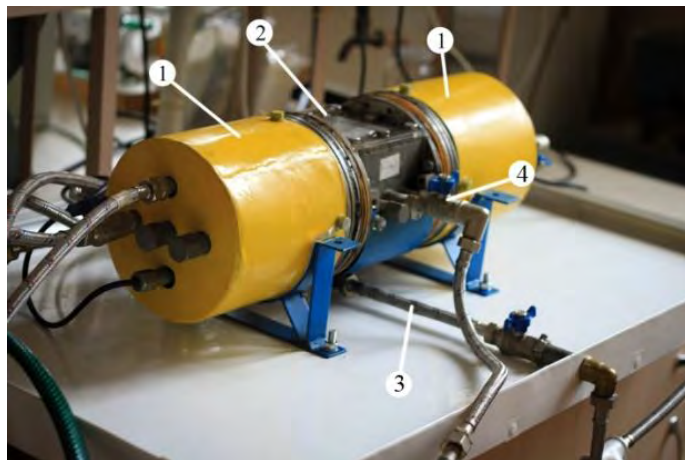

*Fig. 1. Laboratory electromagnetic vibration cavitator:  
1 – electromagnetic vibration drives; 2 – working chamber with three cavitation disks;  
3 – liquid outlet pipe; 4 – liquid inlet pipe*

The electromagnetic vibration cavitator operates on the principle of converting electric energy into mechanical (vibration) by means of electromagnetic wires (Fig. 1). Vibrational oscillations are transmitted to the cavitation chamber 2 by means of sockets connected to cavitation disks. Holes in cavitation disks create a sharp drop in local pressure and a change in the temperature causing formation and a sharp implosion of cavitation bubbles. Due to this, there is a continuous process of fluid cavitation, which flows into the chamber through the inlet and comes out of the outlet.

The pipe 3 is used to remove fluid from the cavitation chamber volume and maintenance of the apparatus. For outlet mode, the outlet pipe 4s is used.

To cool the electromagnetic actuators, water is used which moves through the pipeline along the outer contour of the casing, providing continuous heat transfer and removal of thermal energy. The device is mounted on a pallet with a fixed mount that is on supports that are able to perceive the vibration energy.

For the experiments, a model mixture of isopropyl alcohol (IP) with water ( $C_{IP} = 0.1 \cdot 10^{-3}$  mol/l) was used. The experiment duration was 1 hour. Sampling was done every 15 minutes. Studies were conducted in stationary and flow modes, at variable concentration and frequency of vibration to choose the optimal conditions for the simulation process.

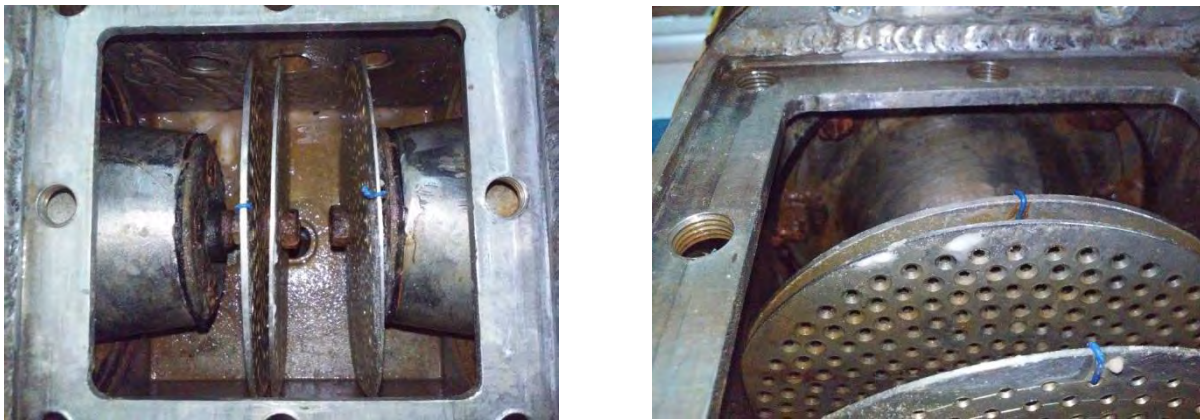

Fig. 2. Cavitation disks inside the working chamber

For a flow mode, a solution of 21 liters has been loaded into a reservoir that was connected to the pump to create a pressure in the system. The volume flow in the system was  $11.4 \times 10^{-5}$  m<sup>3</sup>/s. Then the working chamber was sealed, and the inlet and outlet valves of the branch pipes for open mode were opened.

Changes in model solutions were investigated by determining the chemical oxygen demand (COD) according to the methodology described in [7].

**Results and discussion.** Research of cavitation in the stationary mode was carried out with a constant concentration of solution  $C_{IP} = 0.1 \cdot 10^{-3}$  mol/l and variable cavitation frequency. Results are shown in Table 1.

Table 1

**Results of researches in the stationary mode**

| Frequency, Hz | COD, mg/dm <sup>3</sup> |          |          |          |
|---------------|-------------------------|----------|----------|----------|
|               | 1 sample                | 2 sample | 3 sample | 4 sample |
| 30            | 25.8                    | 23.8     | 22.2     | 20.6     |
| 35            | 24.5                    | 23       | 18.6     | 17       |
| 40            | 21.5                    | 19.5     | 17.8     | 16       |
| 45            | 18                      | 17.5     | 15       | 15       |
| 50            | 18                      | 17       | 16.1     | 14.5     |

The optimal frequency is considered to be 45 Hz because of with its further increase the data of the analysis of chemical consumption of oxygen do not significantly change.

Researches in the flow mode were carried out at the optimal frequency of 45 Hz with a variable concentration of the model solution (Table 2).

Table 2

**Results of researches in the flow mode**

| Concentration of the solution, mol/l | COD, mg/dm <sup>3</sup> |          |          |          |
|--------------------------------------|-------------------------|----------|----------|----------|
|                                      | 1 sample                | 2 sample | 3 sample | 4 sample |
| $0,07 \cdot 10^{-3}$                 | 27.9                    | 20.1     | 10.8     | 10.2     |
| $0,1 \cdot 10^{-3}$                  | 20.5                    | 18.9     | 17.6     | 17       |
| $0,13 \cdot 10^{-3}$                 | 13.5                    | 12.8     | 12       | 10.5     |

For computer simulation we selected experimental data in flow mode for  $C_{IP} = 0.1 \cdot 10^{-3}$  mol/l.

To create a solid-state model, the measurement and removal of laboratory equipment was performed and the equipment parts were simulated in real size (Fig. 3). The details were created using the basic tools for creating solid objects in SolidWorks 2016 Educational Edition.

The simulation of the electromagnetic vibration cavitator was performed. Using the method of creating the “downup” collection with the alternate creation of all the details of the model and their further union, using the geometric relationships between them. The first stage of the implementation of the assembly was the creation of a model of the body of the working chamber. Only the model of the camera was created, since the modeling of the shell of engines does not have any analytical value. Parts were created according to the recommendations [8, 9].

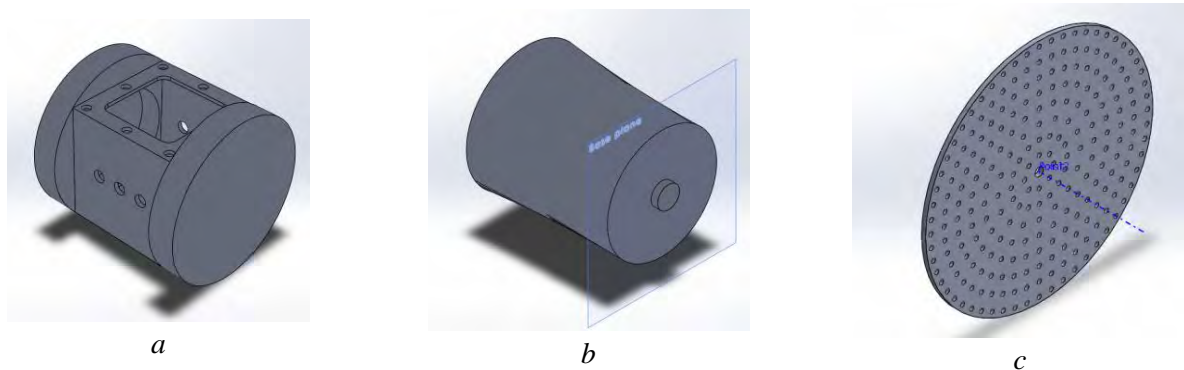

*Fig. 3. Details of the work chamber in SolidWorks 2016 Educational Edition:  
a – the working chamber; b – support shaft; 3 – cavitation disk*

After adding the support part to the assembly, cavitation disk mountings were also created directly in the assembly itself, in order to simplify the process of formation of geometric interconnections. The assembly uses two such details.

After creating a solid-state model of the assembly, the model material and all the preparatory properties for the start of the computer analysis were specified.

The assembly uses three details of the cavitation grids (Fig. 3). The holes in the grids were made using a dual radial array to ensure accuracy in reducing the time spent on their execution.

For computer analysis, the SolidWorks 2016 Educational Edition software module SolidWorks 2016 Flow Simulation was used, which features an optimized simulation mechanism, high-quality display of results, and ease of compilation of comprehensive reports [5].

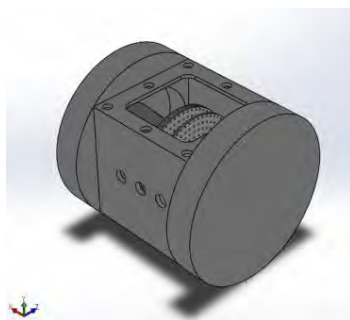

*Fig. 4. SolidWorks 2016 Educational solid-state model – complete assembly of the working chamber with three cavitation disks*

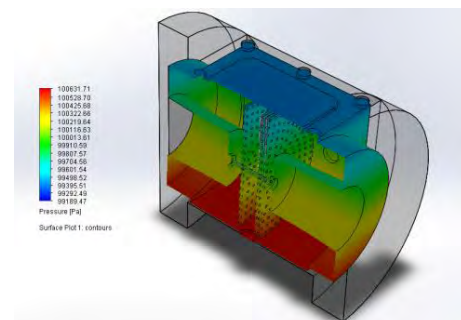

*Fig. 5. The pressure change in the working chamber in SolidWorks 2016 Flow Simulation*

As a result of modeling of hydrodynamic processes in the cavitation chamber of the apparatus results that are presented in graphical form were obtained. Changes in static pressure, temperature and flow velocity are presented in Fig. 5–7 The simulation has been done according to the recommendations [9].

In the working chamber of the apparatus there is a smooth change in static pressure over the vertical section (Fig. 5). Cavitation shifts have a slight effect on the total pressure gradient in the apparatus.

In Fig. 6 there is a sharp change in temperature in the cavitation zone, and a change in the temperature gradient along the cavitation disks. This probably describes the active cavitation disturbances at the point where the disks climb.

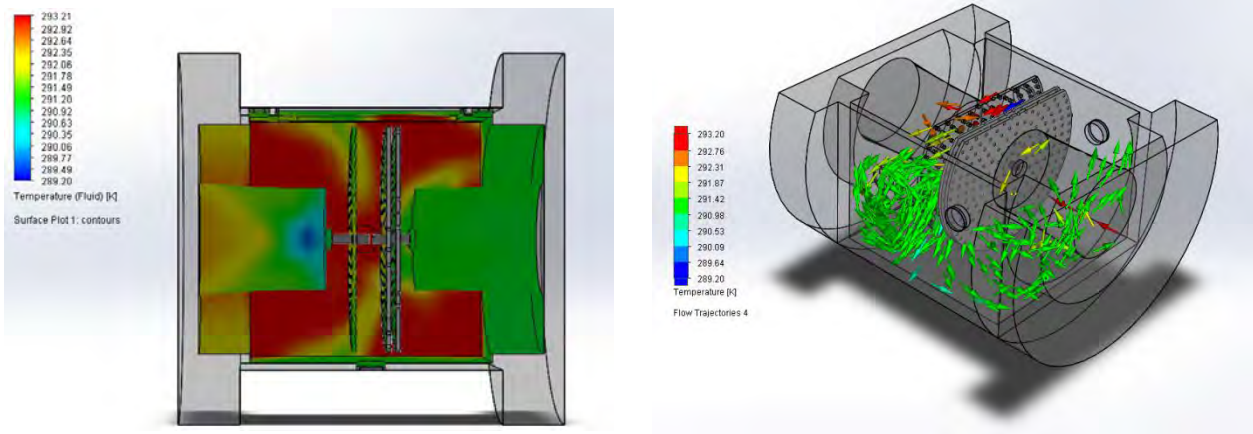

Fig. 6. The temperature change in the working chamber in SolidWorks 2016 Flow Simulation

Computer analysis of the studied process also shows the change in the flow rate in the volume of the working chamber of the laboratory plant (Figure 7).

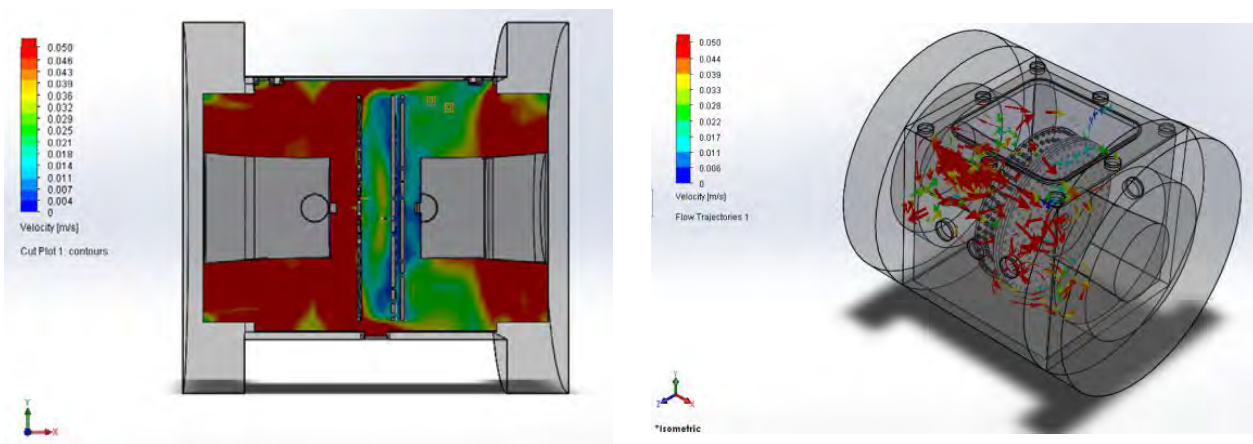

Fig. 7. The flow rate change in the working chamber in SolidWorks 2016 Flow Simulation

**Conclusions.** The study of the process of cavitation in liquid mediums has been carried out, using methods of engineering analysis. A series of experiments was conducted using a laboratory installation of an electromagnetic vibration cavitator. A solid-state model of a laboratory workstation camera has been created using SolidWorks 2016 Educational Edition CAD tools and computer simulation based on it.

The obtained data requires additional analysis and study. However, the research of the cavitation process by engineering analysis shows its own perspective [10]. Further study of the phenomenon of cavitation in liquid mediums by computer simulation will help to predict optimal conditions in the created apparatuses and processes which are carried out there.

**The author is expressing the gratitude to the company “Intersed-Ukraine”, the official representative of SolidWorks Corp. in Ukraine and to professor Volodymyr Starchevskyy, the Head of the Department of General Chemistry of Lviv Polytechnic National University.**

1. Lamb, W. S. *Cavitation and aeration in hydraulic systems*. Bedfordshire, UK. BHRGroup, 1987, 114 p. 2. Rood, E. P. Review – mechanism of cavitation inception. *Trans. ASME, J. Fluids Engng*, 1991, 113, 163–175. 3. Knapp, R. T., Daily, J. W., and Hammitt, F. G. *Cavitation*. McGraw-Hill, New York, 1970. 4. Delannoy, Y. and Kueny, J. L. Two phase flow approach in unsteady cavitation modelling. In *ASME cavitation and multiphase forum*, 1990. 5. Ellis, A. T., *Cavitation in Hydrodynamics*. HMSO, Paper 8, 1956. 6. Martynov S.S., Mason D.J., and Heikal M.R. Numerical simulation of cavitation flows based on their hydrodynamic similarity, 2005. 7. Shevchuk L.I. et al. Nyzkochastotni vibrorezonansni kavitatory, 176, 2013. 8. Tickoo Sham. *Solidworks 2016 for Designers*. CAD/CIM Technologies, 2016. 9. *Instruction for SolidWorks: version for SOLIDWORKS 2016 SP05*. 10. Pidhirnyi R., Hlukhaniuk A., Motrunich O., Ivashchuk O., Starchevskyy V. The simulation of cavitation process using the engineering analysis method. *Proceedings of 7th International Youth Science Forum “Litteris Et Artibus”*. 2017, P. 81–82.