

THERMAL MODERNIZATION OF INDUSTRIAL ROOMS AIR CONDITIONING SYSTEM

© Voznyak O., Sukholova I., Yurkevych Yu., Dovbush O., 2018

An important priority of the economic policy of Ukraine is the careful use of energy. Therefore, a large-scale energy saving policy is being implemented in the country, and energy efficiency objectives are comprehensive and cover both the legislative framework and technical innovations. A large amount of energy is spent on creating an indoor microclimate in industrial rooms. One of the effective ways to reduce energy consumption for cheling needs is to carry out the thermal modernization of the air conditioning system. In this article, the economic indicators of thermal renewal measures during the reconstruction of the air conditioning system of the industrial rooms are given. During the reconstruction of air conditioning system, the following thermal modernization measures were taken for comparison: replacement of the operation of the air conditioning system from the stationary to the alternating, the installation of two-jets air distribution devices, the installation of Belimo automation, the use of laying jets. Opimal renewal measure is determined, taking ino account maximal profit as well energysaving.

Key words: energy saving, air conditioning system, thermal renovation, energy audit.

О. Возняк, І. Сухолова, Ю. Юркевич, О. Довбуш
Національний університет “Львівська політехніка”,
кафедра теплогазопостачання та вентиляції

ТЕПЛОВА МОДЕРНІЗАЦІЯ СИСТЕМИ КОНДИЦІОНУВАННЯ ПОВІТРЯ ВИРОБНИЧИХ ПРИМІЩЕНЬ

© Возняк О., Сухолова І., Юркевич Ю., Довбуш О., 2018

Важливим пріоритетом економічної політики України є ощадне використання енергії. Тому в країні провадять політику енергоощадності, а цілі енергоефективності є всеосяжними та охоплюють як законодавчу базу, так і технічні нововведення. Велику кількість енергії витрачають на створення внутрішнього мікроклімату у виробничих приміщеннях. Одним із ефективних способів зменшення енергоспоживання для потреб охолодження є термічна модернізація системи кондиціонування повітря. Наведено економічні показники заходів термореновації під час реконструкції системи кондиціонування повітря виробничих приміщень. Під час реконструкції системи кондиціонування повітря для порівняння було здійснено такі термомодернізаційні заходи: заміна режиму роботи системи кондиціонування повітря зі стаціонарного на змінний, встановлення двострумних пристроїв розподілу повітря, встановлення автоматики Belimo, використання настільних струмін. Економічне оцінювання передбачає використання сучасної методології оцінювання економічної ефективності систем термомодернізації, яка враховує останні концепції економічних розрахунків, зокрема рекомендації UNIDO (Департаменту з промислового розвитку Організації Об'єднаних Націй). Двострумний повітророзподільник дає змогу роздавати припливне повітря у верхній зоні приміщень різного призначення з утворенням закрученої та плоскої струмін. Через наявність рухомих пластинок, прикріплених до дифузора повітророзподільника, аеродинамічні параметри результуючого повітряного потоку поліпшуються завдяки зменшенню коефіцієнтів загасання швидкості та

температури повітряного потоку. Визначено оптимальний термомодернізаційний варіант з умови отримання максимального прибутку та енергоощадності.

Ключові слова: енергоощадність, система кондиціонування повітря, термомодернізація, енергоаудит.

Introduction. In our time, the issue of energy saving, accounting for energy resources and managing their costs are extremely relevant. In the context of the acute economic crisis, the careful use of energy carriers is an important priority of Ukraine's economic policy. At present, as a priority task, a large-scale energy efficiency policy is being implemented in our country. The tasks of energy saving in Ukraine are complex and cover aspects of both external heat supply and internal engineering systems of buildings (heating, ventilation and air conditioning), as well as the legislative framework and technical innovation. So, a large amount of energy is spent on creating an artificial microclimate in industrial premises. One of the most energy-efficient ways of heating high-rise buildings is the systems with infra-red heaters [1], which allow to purposefully partially heat different zones of the production premises. To reduce heat losses in heat supply systems, it is expedient to insulate fittings and shut-off valves. [2] By improving thermal properties and air tightness of buildings, there is a change of indoor air quality in buildings – without any ventilation (natural or mechanical) there is a significant deterioration of indoor air quality. According to [3] we can conclude that people react to temperature changes in a room more accurately than to changes in odor caused by the changes of CO₂ concentration. Increasing CO₂ concentration is hardly perceived by persons. His performance deteriorates uncontrollably and tiredness occurs sooner than usual. Therefore is currently, it is from the perspective of energy and economic efficiency at the same time more convenient to use mechanical ventilation. [4] There is no doubt that the energy needs for cooling system needs for air conditioning (AC) must also be reduced as a result of thermo-modernization. In order to achieve the maximum effect, it is necessary to determine the economically feasible level of thermal protection of microclimate systems, which should be optimal both in heat engineering and in economic terms. The choice of energy-saving operating conditions of existing refrigerating machines is often carried out using an exergy analysis, which allows the establishment of maximum thermodynamic capabilities of the system, and, accordingly, energy-saving conditions for their operation [5].

Analysis of existing research. One of the most rational ways of air distribution is submission of coming air directly into a room serviced area. For this purpose air distribution devices with high intensity of falling of parameters (velocity V and temperature t) of incoming air are used. As characteristic property of such incoming air jet there is its higher turbulence in comparison with common air jets. Both swirl and laying air jets using is an effective way of increasing its turbulence. In this work the opportunity of achievement of falling high intensity of parameters is considered at distribution of air supply by air distribution device with creation both swirl and spread air jets. The question has been solved due to using of air distribution device with creation both swirl and laying air jets, that leakage from the nozzle at the same conditions.

Aim of work. The aim is to establish economic indicators of thermo-renovation measures during the reconstruction of the air conditioning system of the production premises.

Theoretical research. In the reconstruction of air conditioning systems, such thermal efficient (energy saving) measures (TRM) are worthy of note: replacement of the operation of the AC from the stationary to the alternating, the installation of two-jet air distributors DSPR, the reconstruction of the air distribution system, the installation of Belimo automation, the use of laying jets.

The two-jet air distributor DSPR allows to supply inflow air to the upper area of the room of different purpose [6] with the formation of a swirling and flat laying jet. Due to the presence of moving plates attached to the air distributor diffuser (Fig.), the aerodynamic parameters of the resulting air flow are improved by reducing the coefficients of attenuation of the velocity and temperature of the air flow.

This contributes to the reduction of the air conditioning system's performance. Moving plates allow to increase the angle of expansion of the currents and form a twisted jet with a high intensity of mixing of the tidal air with the air of the working zone. The screw adjustment of the slit makes it possible to change the amount of tidal air passing through the annular gap. The economic assessment implies the use of a modern methodology for assessing the economic efficiency of thermo-modernization systems, which takes

into account the latest concepts of economic calculations, in particular UNIDO (United Nations Industrial Development Organization) recommendations.

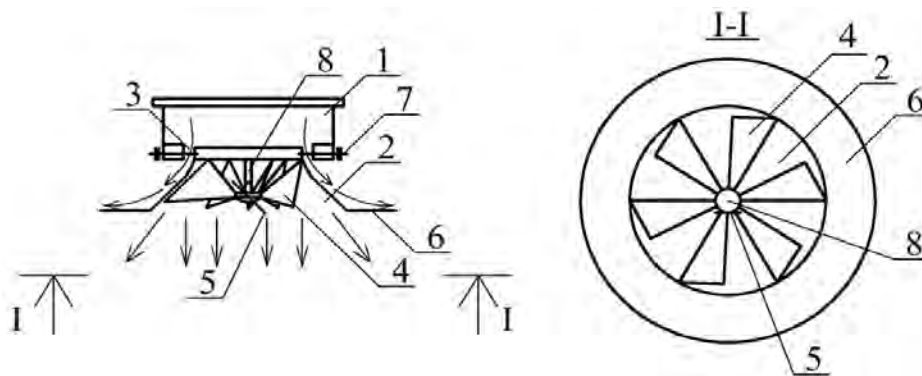

*Two-jet air distributor DSPR with the formation of swirling and flat flooring currents:
1 – inflow branch pipe; 2 – diffuser; 3 – annular adjustable slit; 4 – plates;
5 – control handle; 6 – deflector; 7 – screw adjustment slit; 8 – rod*

According to the concept of UNIDO, by introducing some symbols, for each “simple” TRM, where $i = 1 \div n$, the following basic economic characteristics are defined [7]:

- I_i – investment funds for the realization of the TRM, Euro;
- K_i – annual funds saved by reducing energy consumption of the system with the possible realization of thermal engineering according to the transit route, Euro/year;
- $SPBT_i$ (Simply Pay Back Time – Si) – the simple time of returning funds (expenses), which does not take into account the inflation factor, years;
- $NPVR_i$ (Net Present Value Ratio – Yi) – net worth variable; the profit from the sale of this TRS during the consideration of the investment, Euro;
- IRR_i (Internal Rate of Return) – Internal Rate of Return, %.

There is an objective need to consider additional “cumulative” thermal renewal variants (TRV), with the effect of combining two or more “simple” TRM selected from the “list”. Let us indicate them, according to the selected indexes, in the next way: TRV_{12} (joint activity of fist thermal renewal measure – TRM_1 and 2nd – TRM_2), TRV_{13} (set TRM_1 and TRM_3), TRV_{23} (total effect TRM_2 and TRM_3), TRV_{123} (comprising three thermal renewal measures – TRM_1 , TRM_2 and TRM_3) etc. These thermal renewal variations are called “cumulative” and they should be treated as separate TRV with its indicators: $SPBT$, $NPVR$, IRR , etc. If number of TRM is n , then the total number of TRM is 2^n . The question is which of these $2n$ TRV is the most efficient economically? For the answer it is necessary to consider and analyze the method of conducting the energy audit of the system, after some optimization. The number of “aggregate” TRV is determined by the number of combinations C_n^m , where n is the number of possible TRV from the “list”, and m varies from 0 to n . Consequently, the amount of “aggregate” TRV is numerically equal to the sum of the coefficients of the Newton binomial 2^n .

For the most qualified conducting of energy audit it is expedient to consider the maximum possible number of TRM that can be operated by an energy auditor, that is, the so-called “list” should be as complete as possible. In connection with this, there is a need to create such a method of carrying out the energy auditing, which would allow to avoid bulkiness when considering all possible TRV, giving the opportunity to reduce their quantity in a reasonable way, and at the same time, to determine without fail the most optimal final result – the recommendation of the energy auditor to the customer.

Consequently, in order to optimize, it is necessary to compile a square matrix with the number of rows n and columns m , which, in fact, equals the number of all “simple” TRM, namely n . The number of “aggregate” TRV marked with “+” will increase by 1 in each of the following columns until it reaches the last total of “simple” TRM (Table 1). In it Arabic numerals are numbered “simple” TRM, and Roman – “aggregate” TRM. In this regard, we note that the rows need to be filled with the appropriate thermosetting measures as their parameter S_i increases, that is from $SPBT_{min}$ to $SPBT_{max}$.

Output data for conducting energy audit of the AC: construction site, construction part (plans, sections, building structures, etc.), annual energy consumption for the needs of the cooling system of the air-conditioning system Q_x , MJ/year, cost of energy consumption P_x , Euro/MJ, data for counting Estimated cost of thermo-modernization works I_i , htn, the degree of discount r (economic analysis is carried out under conditions of constant prices and timing of investment consideration $t = 15$ years).

As a result, an optimal thermo-design variant and its economic parameters are determined, and the solution is obtained by the following algorithm:

1. Calculation of annual energy consumption for the needs of cold-water supply AC Q_x , MJ/year and this option is considered “basic” (zero).

2. Choosing a “list” of thermo-educational measures for this system, in particular:

2.1. Replacement of the operation of the SCP from the stationary to the alternating.

2.2. Installation of two-stroke air separators DSPR.

2.3. Reconstruction of the air distribution system.

2.4. Installing automation.

2.5. Application of jets laying.

The cost of electricity is 6,47 eurocent for 1 kV hour (II class voltage up to 27.5 kV for industrial and consumers equal to them with the power up to 750 kVA). The coefficient of conversion of electric energy into cold energy is $\varepsilon = 3 - 5$. Therefore, the value of P_x is taken to be $P_x = 0.007$ Euro/MJ.

3. Calculating energy efficiency ΔQ_i for each TRM as $\Delta Q_i = Q_o - Q_i$, and annual savings K_i , Euro/year.

$$K_i = \Delta Q_i \cdot P_x. \quad (1)$$

Table 1

Characteristics of energy saving measures

No	Measures	Energy costs for the “basic” option Q_o , MJ/year	After the change Q_i , MJ/year	Energy saving $DQ_i = Q_o - Q_i$, MJ/year	Savings money $K_i = DQ_i \cdot P_x$, Euro/year
1.	Replacement of the working regime of the AC	9 233	6 122	3 111	20.67
2.	Installation of DSPR	9 233	6 487	2 746	18.31
3.	Installing automation	9 233	6 122	3 111	20.67
4.	Effect of jets laying	9 233	8 771	462	3.08

4. Capitalization of investment costs I_i and work on each TRM (tabl.2).

5. Determination of indicators of each TRM: $SPBT_i$, $NPVR_i$ and IRR_i (Table 2).

5.1. Calculate the value $SPBT_i$ (S_i):

$$S_i = \frac{I_i}{K_i}. \quad (2)$$

5.2. Calculation of the indicator $NPVR_i$ (Y_i).

To calculate the $NPVR_i$ for the i -th TRV, the annual profits are pre-determined by the formula:

$$K_i' = K_i - T_i - \Delta T_i, \quad (3)$$

where: K_i – annual savings; T_i – taxes; ΔT_i – other expenses, Euro/year.

(it was adopted $T_i = VAT$ in the amount of 20 %, and the value of ΔT_i neglected).

During t years cash flow CF_i :

$$CF_i = K_i' \cdot t \quad (4)$$

The inflation rate A for t years has been determined with a certain degree of discount r , which is taken according to the data of banking institutions:

$$A = \frac{1}{(1+r)^t} \quad (5)$$

Total revenue B during time t :

$$B_i = CF_1 \cdot A \quad (6)$$

Net price variable $NPVR_i$ (Y_i):

$$Y_i = B_i - I_i \quad (7)$$

Table 2

Economic indicators of the renewal measures

N°	Measures	I_i	K_i'	$SPBT_i$	$NPVR_i$	IRR_i
		Euro	Euro/year	(S_i) year	(Y_i) Euro	%
1	Replacement of the working regime of the AC	73.33	20.74	3.54	+237.8	+10.2
2	Installation of DSPR	98.10	18.31	5.36	+179.8	+7.14
3	Installing automation	200.0	20.67	9.64	+111.1	+3.00
4	Effect of jets laying	20.0	3.08	6.49	+26.2	+5.77

5.3. IRR_i – is numerically equal to the discount rate r_i under the condition $NPVR_i = 0$ ($Y_i = 0$), that is, the maximum inflation (r_i), in which the funds invested will pay off inflation, but without profit.

$$Y_i = \frac{K_i' \cdot t}{(1 + r_i)^t} - I_i; \quad (8)$$

Since the condition $Y_i = 0$, then:

$$\frac{K_i' \cdot t}{(1 + IRR_i)^t} = I_i \quad (9)$$

Since, by the definition $t = 15$ years, then $15K_i' = I_i(1 + IRR_i)^{15}$, from where:

$$IRR_i = \left(\frac{15K_i'}{I_i} \right)^{\frac{1}{15}} - 1 \quad (10)$$

6. Conducting optimization for getting of maximal economic effect (Table 3).

Since the consideration of TRM in the amount of 2^n is an extremely cumbersome process, it is advisable to simplify it, using a scientifically based methodology aimed at reducing the required amount of TRM, that is, to carry out appropriate optimization (Table 3).

To carry out such optimization, a matrix (Table 3) with a number of rows n and columns n was constructed, which, in fact, equals the number of all “simple” TRM, namely n . The number of “aggregate” TPM marked with “+” marks will increase by 1 in each subsequent column until it reaches the last total of “simple” TRM (Table 3). In it Arabic numerals are numbered “simple” TRM, and Roman – “aggregate” TRM. The rows in Table 3 are filled with the appropriate thermosetting measures as their S_i parameter rises, that is from $SPBT_{min}$ to $SPBT_{max}$. After determining the economic indicators of all “aggregate” TRM from the composite matrix, the variant with an $NPVR_{max}$ ($Y_j = \max$) is considered as optimal.

Thus, in the general case, the TRM are located in Table 3 in the order of increasing value of $SPBT_i$, and the required TRM_j are considered as aggregate TRM, and the optimal one is considered the TRM, in which the $NPVR_j$ (Y_j) is the largest. It should be noted that the TRM with the $NPVR_i > 0$ and $IRR_i > r$ will be profitable, and $NPVR_j < 0$ and $IRR_j < r$, will be unprofitable. At the same time, it is important to note that a unprofitable TRM in combination with profitable TRM sometimes generates a profitable TRM. But this TRM somewhat worsens the situation and can not have an $NPVR_{max}$, that is, it will not be optimal.

We will optimize the SRT taking into account the data of item 6 and compile table 3 ordered from the first TRM₁ “replacement of the operating mode of the system from the stationary to the alternating”, in which the parameter $SPBT_1$ is minimal, until the last (fourth) installation of automation “with a maximum $SPBT_5$. The optimum, as noted, is that TRM_j, in which $NPVR_j$ (Y_j) is the maximum, namely, TPB_{IV}. This

means that the maximum economic effect will be in the case of the simultaneous application of four TRM (Table 3). It should be noted that the optimization carried out is complete, despite the fact that the total amount of TRM in the selected 4 TRM is $2^4 = 16$, and the required amount of TRM is $N = 4$, that is, the presented method gave the opportunity to reduce the amount of TRM by 4 times. The specific profit from the introduction of energy-saving technologies during the period of their operation is 500 – 550 Euro.

Table 3

Optimization of options according to paragraph 6

No	Measures	Variants			
		I	II	III	IV
1	Replacement of the working regime of the AC	+	+	+	+
2	Installation of DSPR		+	+	+
3	Effect of jets laying			+	+
4	Installing automation				+
	Indexes				
1	Investment expenses I (Euro)	73.33	171.43	191.43	391.43
2	Annual savings K (Euro)	20.74	39.05	42.13	62.87
3	Simple time of returning expenses- $SPBT$ (year)	3.54	4.39	4.54	6.23
4	Net Present Value Ratio – $NPVR$ (Euro)	+237.77	+414.27	+440.47	+551.57
5	Internal Rate of Return – IRR (%)	+10.2	+8.58	+8.33	+6.07

Conclusions. In the case of the number n of “simple” TRM it is not necessary to consider the whole complete set of TRV, which includes 2^n variants, and only n “aggregate”, methodically determined variants. The use of DSPR will enable the design of energy-saving air distribution schemes in the AC for small-scale production facilities with the provision of standard air parameters in the alternating mode. The air distribution layers with application of flooring jets are effective, since they allow to save energy costs for AC about 5 %. With the use of air distribution in non-stationary mode, cold storage is about 40 %. AC with Belimo’s automation, although having a payback period that exceeds the regulatory (9.6 years), is also attractive because it provides energy savings of about 30 % at relatively low capital costs.

1. Возняк О. Т., Сухолова І. Є. Патент України 40185. Повітророзподільник. – Заявка u200813086. – Опубл. 25.03.2009. – Бюл. № 6. – 2 с. 2. Возняк О. Т., Sukholova I., Myroniuk K. Research of device for air distribution with swirl and spread air jets at variable mode // *Eastern European Journal of Enterprise Technologies*. 6/7 (78) 2015. pp.15 – 23. 3. Возняк О. Т., Юркевич Ю. С., Желих В. М. Теоретичні передумови оптимізації сукупних термореновацій при проведенні енергетичного аудиту будинку // *Вісник Нац. ун-ту “Львівська політехніка”*. – 2003. – № 476: “Теплоенергетика. Інженерія доквілля. Автоматизація” – С. 140–145. 4. Возняк О. Т., Сухолова І. Є. Методи зниження енерговитрат // *Ринок інсталяцій № 9 (157)*, 2010. – с. 16. 5. Возняк О. Т., Сухолова І. Є., Миронюк Х. В. Повітророзподіл закрученими струминами у приміщеннях малого об’єму // *Вісник НУ “Львівська політехніка” „Теорія і практика будівництва“*. – 2011. – № 697. – С. 60–63. 6. Возняк О. Т., Сухолова І. Є., Савченко О. О., Довбуш О. М. Термореновація системи кондиціонування повітря виробничих приміщень // *Вісник Одеської державної академії будівництва та архітектури*. Вип. № 68, 2017. – С. 114–120. 7. Возняк О. Т., Сухолова І.Є., Миронюк Х. В. Енергоощадність при повітророзподілі настільними струминами // *Вісник Нац. ун-ту “Львівська політехніка” „Теорія і практика будівництва“*. – 2013. – № 755. – С. 44–47. 8. Kapalo P. Ventilation and indoor air quality in the classroom / 2015. In: *Visnik NU „Lvivska politechnika”*: Serija: Teoria i praktika budivnictva. No. 823 (2015), p. 341–345. – ISSN 0321-0499. 9. Kapalo P. Assessment of mechanical ventilation with heat recovery for the class room – case study / 2016. In: *Design of energy efficient buildings 2016: Proceedings of Scientific Papers*. – Košice: TU, 2016 S. 31–36. – ISBN 978-80-

553-3064-8. 10. P. Kapalo, S. Vilcekova, O. Voznyak. Using experimental measurements the concentrations of carbon dioxide for determining the intensity of ventilation in the rooms // *Chemical Engineering Transactions*. Vol.39, 2014 ISBN 978-88-95608-30-3; ISSN 2283-9216, – P. 1789–1794. 11. Kapalo P., Voznyak O. T. Experimental measurements of a carbon dioxide concentration for determining of a ventilation intensity in a room at pulsing mode. // *Czasopismo Inzynierii Ladowej, Srodowiska i Architektury*, tom XXXII, zeszyt 62 (nr 4/2015). – S. 201–210. 12. Возняк О. Т., Сухолова І. Є., Миронюк Х. В. Підвищення ефективності повітророзподілу в приміщенні при використанні закручених струмин // *Збірник MOTROL “Motorization and Power industry in agriculture”*, vol. 12 C, 2010. – С. 210–214. 13. Savchenko O., Zhelykh V., Voll H. Analysis of the systems of ventilation of residential houses of Ukraine and Estonia // *SSP – Journal of Civil Engineering*. 2018. Vol. 12, Issue 2. p. 23–30. 14. Жуковський С. С., Лабай В. Й. Аеродинаміка вентиляції. – Львів: Видавництво Нац. ун-ту „Львівська політехніка”, 2003. – 372 с.

References

1. Vozniak O. T., Sukholova I. Y. Patent Ukrainy 40185. Povitrorozpodilnyk [Air distribution device] – *Zajavka u200813086*. – *Opubl.* 25.03.2009. – *Bul. No.* 6. – 2 p. [in Ukrainian]. 2. Voznyak O. T., Sukholova I., Myroniuk K. Research of device for air distribution with swirl and spread air jets at variable mode // *Eastern European Journal of Enterprise Technologies*. 6/7 (78) 2015. pp.15–23. 3. Vozniak O. T. Teoretychni peredumovy optymizacii sukupnykh termorenovacij pry provedenni energetychnogo audydu budynku [Theoretical preconditions for optimization of combined thermoenergy during energy audit of a building] / O. T. Vozniak, Y. S. Yurkevych, V. M. Zhelykh // *Visnyk NU “Lvivs’ka politehnika”*. – 2003. – No. 476: *Teploenergetyka Ingeneria dovkilli. Avtomatyzacija* – p. 140–145 [in Ukrainian] 4. Vozniak O. T., Sukholova I. Y. Metody znyzhennia enerovytrat. [Methods of energy consumption reducing] // *Rynok instaliatsij No. 9 (157)*, 2010. – s. 16 [in Ukrainian] 5. Voznyak O. T., Sukholova I. Y., Myroniuk Kh. V. Povitrorozpodil zakruchenymy strumynamy u prymishchenniakh maloho ob’yemu [Air distribution with twisted jets in small rooms] / *Visnyk NU “Lvivs’ka politehnika” „Teorija i praktyka budivnytstva”*. – 2011. – No. 697. – s. 60–63 [in Ukrainian]. 6. Voznyak O. T., Sukholova I. Y., Savchenko O. O., Dovbush O. M. Termorenovatsiya systemy kondytsionuvannia povitria vyrobnychkykh prymishchen’, [Thermotherapy of the air conditioning system of industrial premises] // *Visnyk Odes’koyi Derzhavnoyi akademiyi budivnytstva ta arhitektury. Vypusk No. 68*, 2017. – s. 114–120 [in Ukrainian]. 7. Voznyak O. T., Sukholova I. Y., Myroniuk Kh. V. Energooshchadnist’ pry povitrorozpodili nastyl’nyimi strumynamy [Energy saving at air distribution by floor jets] / *Visnyk Nacionalnogo universytetu “Lvivs’ka politehnika” „Teorija i praktyka budivnytstva”*. – 2013. – No. 755. – s. 44–47 [in Ukrainian]. 8. Kapalo P. Ventilation and indoor air quality in the classroom / 2015. In: *Visnik nacional’noho universitetu Lvivska politehnika. Serija: Teoria i praktika budivnictva. No. 823 (2015)*, p. 341–345. – ISSN 0321-0499. 9. Kapalo P. Assessment of mechanical ventilation with heat recovery for the class room – case study / 2016. In: *Design of energy efficient buildings 2016: Proceedings of Scientific Papers*. – Košice: TU, 2016. S. 31–36. – ISBN 978-80-553-3064-8. 10. P. Kapalo, S. Vilcekova, O. Voznyak. Using experimental measurements, the concentrations of carbon dioxide for determining the intensity of ventilation in the rooms. // *Chemical Engineering Transactions*. Vol. 39, 2014 ISBN 978-88-95608-30-3; ISSN 2283–9216, – p. 1789–1794. 11. Kapalo P., Voznyak O. T. Experimental measurements of a carbon dioxide concentration for determining of a ventilation intensity in a room at pulsing mode. // *Czasopismo Inzynierii Ladowej, Srodowiska i Architektury*, tom XXXII, zeszyt 62 (nr 4/2015). – S. 201–210. 12. Voznyak O. T., Sukholova I. Y., Myroniuk H. V. Pidvyshchennia efektyvnosti povitrorozpodilu u prymishchenni pry vykorystanni zakruchenyykh strumyn [Increase the efficiency of air distribution in the room using twisted jets] / *Zb. MOTROL “Motorization and Power industry in agriculture”*, volume 12 C, 2010. – S. 210–214, [in Ukrainian]. 13. Savchenko O., Zhelykh V., Voll H. Analysis of the systems of ventilation of residential houses of Ukraine and Estonia // *SSP – Journal of Civil Engineering*. 2018. Vol. 12, Issue 2. p. 23–30. 14. Zhukovs’kyy S. S., Labay V. Y. Aerodynamika ventyliatsiyi [Aerodynamics of ventilation]. – Lviv: Vydavnytstvo NU „Lvivs’ka politehnika”, 2003. – 372 s. [in Ukrainian].