

## POLYOLEFIN COMPOSITIONS. STUDY OF PROPERTIES OF THE FLAME RETARDANTS CROSS LINKING COMPOUNDS

*Olena Chulieeva<sup>1,\*</sup>, Volodymyr Zolotaryov<sup>1</sup>*

DOI: [dx.doi.org/10.23939/chcht11.01.055](https://doi.org/10.23939/chcht11.01.055)

**Abstract.** Flame-retardants cross-linking polyolefin compounds were obtained. It is shown that it is possible to obtain polyolefin compounds with high fire and cross-linking rates at the same time by changing the ratio between the cross-linking components, flame-retardants and processing parameters.

**Keywords:** self-supporting wires, combustibility, limiting oxygen index, flame-retardant agents, antimony halides, flame-retardant and cross-linking polyolefin compounds.

### 1. Introduction

Industrial production of modern self-supporting wires (SSW) requires application of new progressive polymeric materials – silane cross-linking polyolefin compounds, with the set combinations of properties.

An important factor, which restrains introduction of these polymeric materials during the cable production, is inherent for polyolefin fire hazard that is conditioned by combustibility and processes, which accompany it, *i.e.* the possibility of material to ignite and to propagate flame. Combustibility is a complex description of material, which unites the ignition point or spontaneous combustion, the speed of burning down and flame propagation by the material surface, as well as limit parameters, which characterize independently supported burning process without application of an ignition source. Limiting oxygen index (LOI) is one of the estimation methods of combustibility [1-3]. LOI is the minimum concentration of oxygen in oxygen-nitrogen mixture, expressed in percentages that supports combustion of a polymer under the conditions of the special tests. It characterizes the flammability of polymers.

During development and use of silane cross-linking polyolefin compounds, it is necessary to apply the set of methods providing the reduction of the material ability to flash, to sustain and propagate combustion.

Flame-retardant thermoplastic polyethylene compounds (PE) are used in cable industry during a few decades. The combination of the halides and the antimony trioxide ( $\text{Sb}_2\text{O}_3$ ) is used to give the flame-retardant properties for PE composition. Low density polyethylene compositions (LDPE) are capable of fading and flash under the ignition source, but they are helpless to the independent burning after deleting the last one.

Many halogen organic compounds were developed and used as flame-retardant agents for thermoplastics. Bromine and chlorine agents are the main. Using flame-retardant agents in combination with the silane cross-linking systems is interesting. Polymeric compounds with have flame-retardant properties were developed. The decrease in their combustibility is achieved by using the silane cross-linking systems in combination with flame-retardant additives – a mixture of halogen agent with the antimony trioxide ( $\text{Sb}_2\text{O}_3$ ).

The low cost, stability, general properties and efficiency relative to flame-retardant agents are the criteria of the halogen agent choice. Bromine and chlorine organic agents are most widely used. Bromine agents are more effective than chlorine agents; however chlorine agents are used more often, because chlorine is more stable and cheap than bromine. Halogen agents must not be decomposed during processing and exploitation of plastic goods, which contain it.

There was a necessity of making the XLPE and flame-retardant agent at the same time in Ukraine in accordance with electric installation code, Ukrainian and European standards [4-10].

So, the aim of this work is the study of properties which characterize combustibility of silane cross-linking flame-retardant polyolefins if we use the cross-linking system which contains vinyltrimethoxysilane (VTMS) in

<sup>1</sup> PJSC YUZHicable Works  
7, Autogenna St., 61099 Kharkiv, Ukraine  
\* [echuleeva@mail.ru](mailto:echuleeva@mail.ru)  
© Chulieeva O., Zolotaryov V., 2017

combination with chlorine or bromine organic agents and antimony trioxide ( $\text{Sb}_2\text{O}_3$ ).

## 2. Experimental

Polyolefins (low-density polyethylene (LDPE), linear low-density polyethylene (LLDPE) and their mixture); flame-retardant additive which are the mixtures of chlorine or bromine organic agents and  $\text{Sb}_2\text{O}_3$  with 3:1 ratio and VTMS cross-linking systems were used during conducting of researches. The properties of materials are resulted in Tables 1 and 2.

The liquid cross-linking system that consists of VTMS, initiator and cross-linking catalyst was introduced into a polymeric matrix as 40 % concentrate based on polymer. As the result, we had dry silane masterbatch (DSM) [2]. DSM was fed directly into the extruder during cable production.

ERMAFA compounding line was used for the manufacturing of polyolefin compounds 1-6 (Table 3). Twin-screw extruder BTS 50-35 D with the screw diameter of 0.05 m and an  $L/D$  ratio of 35 was used.

ROSENDAHL isolation line that has an extruder RE 1-120 ARZ with the screw diameter 0.03 m and an  $L/D$  ratio 30, was used for manufacturing of test samples of self-supporting wires 2x35 of polyolefin compounds 1-6.

We investigated the influence of each flame-retardant component, and parameters of the cross-linking process.

The limiting oxygen index was determined according to [6]. In obedience to a method the cross-linking value was evaluated by gel fractions value [11]. The thermal deformation and residual elongation were determined according to [5]. Test for vertical flame propagation for a single insulated wire was determined according to [7]

## 3. Results and Discussion

Fire hazard descriptions and combustibility are often contradictory, and the improvement of one property is accompanied by worsening of another. Moreover, additives that reduce the fire hazard of polymeric materials, usually worsen physical, mechanical, electric and other operating and technological properties, and increase the prime price of materials. So, lowering fire hazard of polymeric materials is a task of optimisation of materials descriptions that we shall reach.

First the LOI changes depending on the content of flame-retardant agents were determined. Results are given in Fig. 1.

Table 1

**Polyolefin properties**

Property	LDPE	LLDPE	LDPE+LLDPE
Density, $\text{kg/m}^3$	$918.5 \pm 15$	$920 \pm 15$	$920 \pm 15$
Melt flow rate, g/10 min, 463 K, 21.6 N	$2.0 \pm 0.1$	$2.0 \pm 0.1$	$3.0 \pm 0.1$

Table 2

**Flame-retardants agent properties**

Property	Chlorine organic agent (ClOA)	Bromine organic agent (BrOA)
Content, %:		
– bromine	–	83
– chlorine	70	–
Melting point, K	349	578.4
Decomposition point, K	623	753

Table 3

**Polyolefin compounds**

Compound	Ingredients
1	LDPE + flame-retardant ( $\text{ClOA} + \text{Sb}_2\text{O}_3$ )
2	LLDPE (melt flow rate 3.0) + flame-retardant ( $\text{ClOA} + \text{Sb}_2\text{O}_3$ )
3	LLDPE (melt flow rate 2.0) + flame-retardant ( $\text{ClOA} + \text{Sb}_2\text{O}_3$ )
4	LDPE + flame-retardant ( $\text{BrOA} + \text{Sb}_2\text{O}_3$ )
5	LLDPE (melt flow rate 3.0) + flame-retardant ( $\text{BrOA} + \text{Sb}_2\text{O}_3$ )
6	LLDPE (melt flow rate 2.0) + flame-retardant ( $\text{BrOA} + \text{Sb}_2\text{O}_3$ )

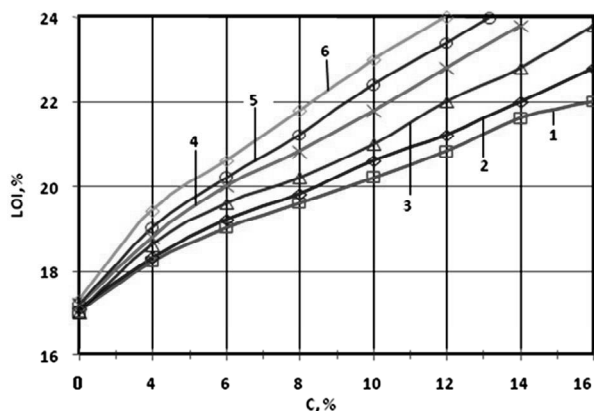
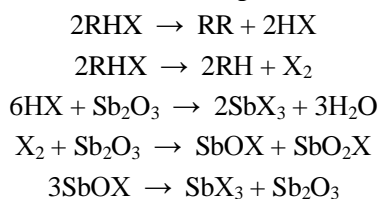


Fig. 1. LOI dependence on flame-retardant agents content for compounds 1-6

According to theoretical presentations, the efficiency of halogen organic agents is determined by lightness with which they are decomposed and reactionary halogen is evolved [10]. The most effective agents that are used as flame-retardant additives for thermoplastic are the long-chain aliphatic agents of halogen with a low energy of halogen-carbon connection. Melting and decomposition of these agents usually take place at low temperatures and are accompanied by the emission of aromatic halogen or acid that contains halogen. However, properties, which make them so effective flame-retardant agents, at the same time restrict their applications in plastics, processing of which must be carried out at temperatures lower than decomposition temperature of these agents. Energy of halogen-carbon link in halogen cyclo-aliphatic hydrocarbons is higher than the energy of link in halogen linear aliphatic agents. So, melting and decomposition of cyclo-aliphatic compounds usually take place at high temperatures. They remain stable up to 623 K and higher, however they are less effective flame-retardants than linear agents.

The use of antimony trioxide ( $\text{Sb}_2\text{O}_3$ ) as a flame-retardant is not effective. It is necessary to activate it with the purpose to increase its efficiency, and halogen agent comes forward in this role. It is decomposed during heating with the emission of halogen acid or active halogen. The products of decomposition react with antimony trioxide, forming antimony(III) halides or antimony halogen oxide, which are flame-retardant agents. The halogen selection and cooperation with antimony trioxide occur according to the Scheme :



where R is an organic radical; X is a halogen (bromine or chlorine).

Two hypotheses that explain flame-retardant antimony(III) halides properties were offered [10]. According to one of them there is reaction between the polymer and halides antimony that leads to the formation of the non-combustible hard products (the slag) instead of combustible gases. The slag reduces the gassing even more, operating as a heat fan, protecting a polymer under it from consequent thermal destruction. Flame-retardant agent also contributes to formation of inert atmosphere that represses burning, diminishing access of oxygen to flame. In obedience to other hypothesis, antimony(III) halides evaporates and is decomposed in flame to different antimony agents and halogen radicals. These decomposition products act as a flame retarder by dissipation of energy and changing of flame chemical structure. Antimony agents are the dissipater of energy, and free halogen radicals change chemical processes of burning.

Flame retardant action of the mixture that contains the antimony trioxide with the halogen compound is determined by the ratio of antimony and halogen, availability of halogen agent and type of decomposition products. The mixtures of halogen agents which eliminate halogen acid, create only antimony(III) halides at halogen:antimony ratio of 3:1. When the ratio is lower, or if the main product of decomposition is an elementary halogen, the mixture of antimony(III) halides or antimony halogen oxide is formed.

Fig. 1 shows that LOI values rise up with the increase of quantity of flame-retardants in all polymeric compounds.

The LOI value is higher if we use LLDPE as compared to LDPE, and if we use the mixtures of bromine agents and  $\text{Sb}_2\text{O}_3$  as the flame-retardant agent. Thus, cross-linking compounds containing the mixtures of antimony and halogen agents with the higher melting and decomposition temperature have higher LOI values than compounds with lower melting and decomposition temperatures of halogen agent.

The dependence of cross-linking values change on the quantity of flame-retardant agent arises interest.

For cross-linking polymeric compounds the cables test samples were hold in water at 363 K. Fig. 2 shows the test results.

The increase in flame-retardant agent content in compositions with identical DSM content (2.5%) decreases cross-linking values (gel fraction). An especially sharp decline is observed for test sample, whereas flame-retardant agent mixture we used chlorine organic agents and  $\text{Sb}_2\text{O}_3$  (curves 1, 2, 3) and less sharp if we used the mixture of bromine agents and  $\text{Sb}_2\text{O}_3$  (curves 4, 5, 6).

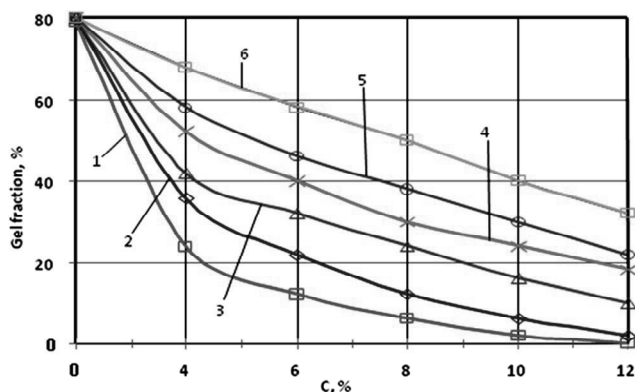


Fig. 2. The dependence of cross-linking values (gel fraction) on flame-retardant agents content for compounds 1-6 with identical DSM concentration of 2.5 %

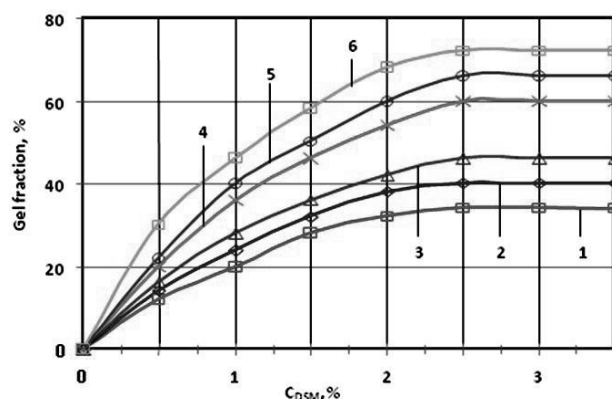


Fig. 3. The dependence of cross-linking values (gel fraction) on DSM concentration for compounds 1-6

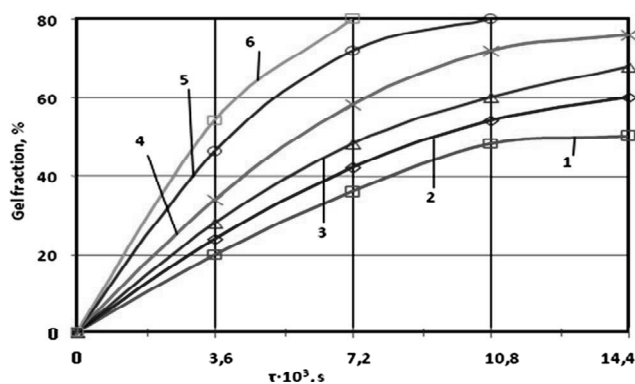


Fig. 4. The dependence of cross-linking values (gel fraction) on processing time for compounds 1-6 with identical DSM concentration of 2.5 %

The processing temperature for polyethylene is within 408–483 K. It is possible to reduce its combustibility by introduction of Sb<sub>2</sub>O<sub>3</sub> in combination with the chlorine paraffin, that are easily melt, or with more stable cyclo-aliphatic or aromatic halogen agents.

However deceleration of VTMS inoculation processes and the next cross-linking process takes place using chlorine organic agents. Compositions, which contain bromine agents and Sb<sub>2</sub>O<sub>3</sub>, have a higher cross-linking level than compositions with chlorine organic agents instead of bromine, because decomposition temperature of the bromine organic agent is higher than that of chlorine organic agents (Table 2).

The cross-linking level change depends on the DSM concentration (Fig. 3) and processing time (Fig. 4).

The cross-linking level rises with the increase in DSM concentration and cross-linking time.

An important characteristic of cross-linking polymer compounds are:

- thermal deformation after test samples holding during 900 s at 473±3 K;
- elongation at tensile force of 0.2 MPa, and also residual elongation, after the removal of tensile force and cooling.

The results of these researches are given in Figs. 5 and 6.

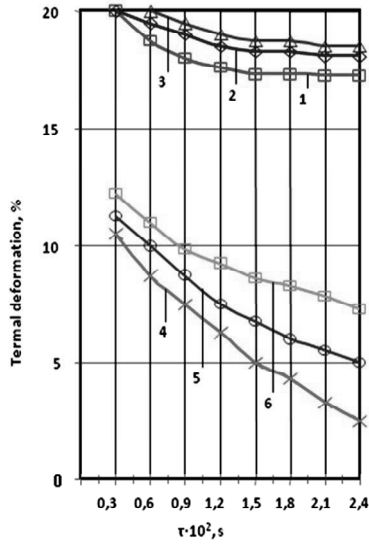
These researches show that compositions, which contain chlorine organic agents and Sb<sub>2</sub>O<sub>3</sub> mixture, have a very large thermal deformation and remaining relative lengthening, after the removal of tensile force and cooling, that is common for the insufficient cross-linking level of polymers, or testifies to the creation of ineffective chemical bond.

The thermal deformation and residual elongation for compositions, which contain bromine organic agents and Sb<sub>2</sub>O<sub>3</sub> mixture meet the requirements EN 60811 [5] even after keeping in water, during which cross-linking takes place, for less than 1 h. The cross-linking process takes place especially effective for LLDPE compositions, which have a melt flow rate of 2.0 g/10 min.

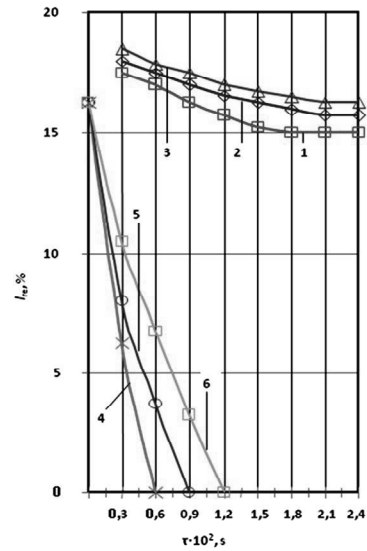
In accordance with the requirements of Ukrainian standards, the flame-retardant self-supporting wire (SSW) have to maintain a flame-retardant test, on condition of single gasket of wire (EN 60332-1-1:2004) [7].

The dependence of the distance between the bottom of the upper charring area ( $L_{bu}$ ), the top of the lower charring area ( $L_{ll}$ ) and the time during which flame test sample is fading on the concentration of flame-retardant agent of different nature in silane cross-linking polymeric compounds were explored. The arrangement of test sample at the flame distribution test for a single vertical insulated wire is given in Fig. 7.

The above mentioned data enable to assert that combustibility of the polymer compositions decreases with the increase in flame-retardant agents content. Bromine agents and Sb<sub>2</sub>O<sub>3</sub> mixture is more effective in reducing combustibility of silane cross-linking polymeric compounds, than mixture of chlorine agents and Sb<sub>2</sub>O<sub>3</sub>.

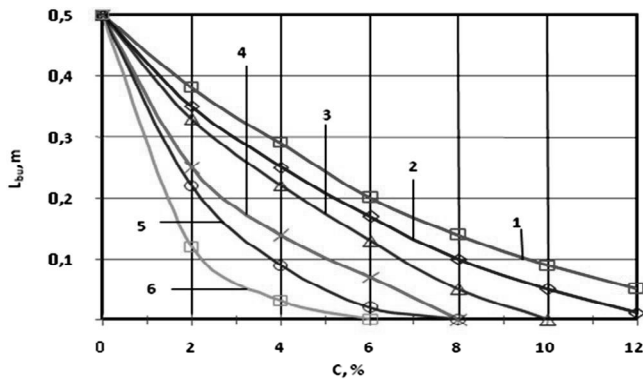
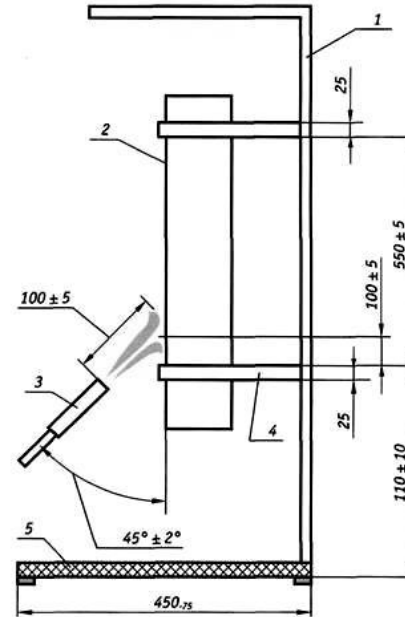


**Fig. 5.** The thermal deformation as a function of processing time for compounds 1-6

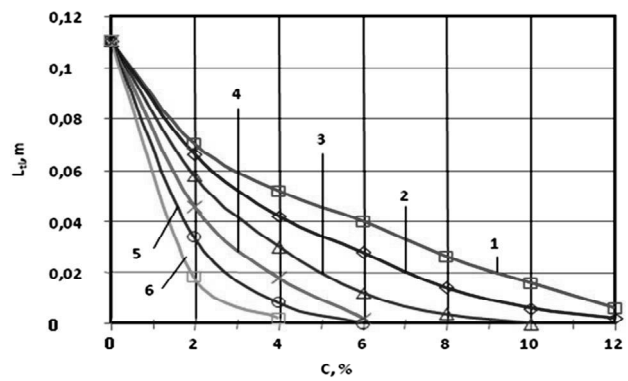


**Fig. 6.** The residual elongation as a function of processing time for compounds 1-6

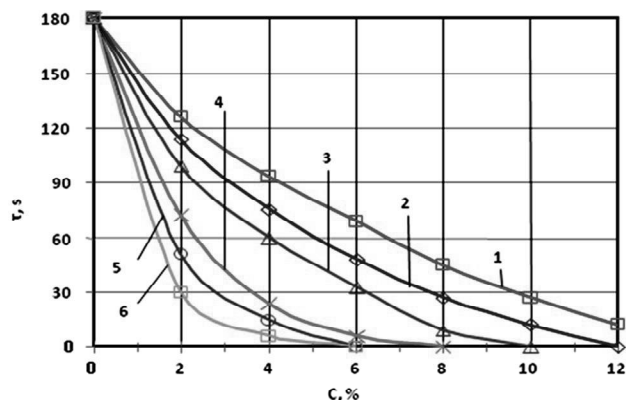
**Fig. 7.** Arrangement of test sample in test apparatus at the flame distribution test on a single vertical insulated wire: stand (1); test sample (2); ignition source (3), fastening (4) and packing white wooden board 0.45x0.01x0.3 m (5)



**Fig. 8.** The distance of the bottom of the upper charring ( $L_{bu}$ ) as a function of the concentration of flame-retardant agent content for compounds 1-6



**Fig. 9.** The distance of the top of the lower charring area ( $L_{tl}$ ) as a function of the flame-retardant agent concentration for compounds 1-6



**Fig. 10.** The time during which flame test sample is fading as a function of the flame-retardant agent concentration for compounds 1-6

The sample is considered to be successfully tested if it is not ignited, or if it takes place but under following conditions: if the flame on the test sample fades not more than within 30 s after removal of ignition source; the packing paper does not ignite or the wooden board is not burned; if the distance between the lower edge of the top support and the onset of charring is greater than 0.05 m.

The results of tests are given in Figs. 8-10.

Thus, with the purpose of combustibility reduction according to the requirements of normative documentation, silane cross-linking polymeric compounds should contain 8–12 % of chlorine agents and  $Sb_2O_3$  mixture or 3–6 % of bromine agents and  $Sb_2O_3$  mixture.

#### 4. Conclusions

On the basis of theoretical and experimental researches an important for cable industry problem of the development of silane cross-linking flame-retardant polyolefin compounds was solved, and their properties were studied. The results of the research may be used for the development of modern technologies of silane cross-linking flame-retardant polyolefin compounds, using the

LDPE, LLDPE and flame-retardant agents, which are a mixture of halogen and  $Sb_2O_3$ .

#### References

- [1] Chulieieva E. and Vasilets L.: Vestnik Nats. Techn. Univ. KhPI, 2000, **127**, 10.
- [2] Chulieieva E., Zolotaryov V. and Pakharencov V.: Plast. Massy, 2009, **10**, 41.
- [3] Peshkov I.: Materialy Kabelnogo Proizvodstva. Mashinostroenie, Moskva 2013.
- [4] <http://eom.com.ua/index.php?action=downloads;sa=view;down=1499>
- [5] EN 60811-507:2012 Electric and optical fibre cables – Test methods for non-metallic materials – Part 507: Mechanical tests – Hot set test for cross-linked materials.
- [6] ISO 4589-2-1996 Plastics-determination of burning behavior by oxygen index – Part 2: Ambient-temperature test.
- [7] EN 60332-1-1:2004 Tests on electric and optical fibre cables under fire conditions – Part 1-1: Test for vertical flame propagation for a single insulated wire or cable – Apparatus.
- [8] [www.kdpu-nt.gov.ua/](http://www.kdpu-nt.gov.ua/)
- [9] Selikhov N.: Antipireny: Sovremennye Tekhnologicheskie Aspekty Proizvodstv i Primeneniya, Analiz Rynochnoy Koniunktury. Cherkassy 2007.
- [10] Kodolov V. Horuchesty i Ohnestoikosty Polymernykh Materialov. Khimiya, Moskva 1976.
- [11] ISO 10147:2011 – Pipes and fitting made of crosslinked polyethylene (PE-X) – Estimation of determination of the gel content.

Received: August 30, 2015 / Revised: October 12, 2015 / Accepted: February 13, 2016

#### КОМПОЗИЦІЇ ПОЛІОЛЕФІНІВ. ВИВЧЕННЯ ВЛАСТИВОСТЕЙ КОМПОЗИЦІЙ, ЗДАТНИХ ДО ЗШИВАННЯ ТА САМОЗАГАСАННЯ

**Анотація.** Отримано композиції поліолефінів, які здатні до зшивання та самозагасання. Показано, що змінюючи співвідношення між компонентами системи зшивання, антипірени та параметри проведення процесу, можна отримати композиції поліолефінів, що забезпечують одночасно високі показники пожежної безпеки і високі ступені зшивання.

**Ключові слова:** силові ізольовані проводи, горючість, кисневий індекс, антипірени, галогенід сурми, композиції поліолефінів, здатні до зшивання та самозагасання.