

Development of Experimental Horizontal-Axis Wind Turbine with Sail-Type Blades

Vitaliy Korendiy, Oleksandr Bushko,
Volodymyr Barabash

Department of Mechanics and Automation Engineering,
Lviv Polytechnic National University, UKRAINE, Lviv,
S. Bandery street 12, E-mail: vitaliy.nulp@gmail.com

Abstract – The analysis of structure of horizontal-axis wind turbine with sail-blades is carried out. Its operational features are overviewed. The technique of experiment replication is developed. The scopes of further investigations are presented.

Key words – wind turbine, wind-wheel, sail-type blade, power regulation, facing of wind-wheel into the wind.

I. Introduction

At the present stage of development of industry and manufacture, the tendency of searching energy-conservative technologies and alternative energy sources becomes more and more relevant [1]. This tendency is caused by the necessity of considerable reducing of production first cost, of improvement of ecological situation and of increasing of energy-independence of large amount of industry branches [1]. The special role in this situation belongs to alternative energy sources and particularly to wind energy, which was successfully used in various spheres of human activity.

At the present time, only several production prototypes of wind turbines use sail-type blades [2]–[4]. In part, this fact may be explained by insufficient substantiation of efficiency problems of such blades, used in wind turbine structures on territories with low wind potential. That is why the problems, related with investigation of efficiency of sail-type blades and development the technique of their calculation and designing, are actual at the present time.

II. Structure and operation features of horizontal-axis wind turbine with sail-blades

Let us consider the structure of slow-speed horizontal-axis wind-wheel with sail-type blades (Fig. 1), designed by the authors of this paper in Lviv Polytechnic National University. The basic structural characteristic properties of this wind-wheel consist in horizontal placement of main drive shaft 1, absence of active system of facing of wind-wheel into the wind, large number of sail-type blades 3 (usually more than 6; in this case we take 8 blades), usage of the mechanism of blades folding up 4 as the system of anti-storm protection.

The basic elements of wind-wheel structure are: axes and sails of blades 3, hub 5, hinges (joints) of blades attachment, main drive shaft 1, supporting bearings 6 of the main shaft, turning (rotating) unit 2 of the mechanism of facing of wind-wheel into the wind, mechanism of changing of blades inclination angle, formed by rocker, connection rod, slider and regulation spring (it is not presented in the Fig. 1), electric generator 7 and tower 8. The operation of the wind-wheel is carried out due to

interaction between blades sails 3 and incoming airflow. The aerodynamic lift force causes rotation of blades axes 3 together with the hub 5 and main drive shaft 1, to which a loading device (electric generator, pump, compressor etc.) is connected. Taking into account the large sail area of such wind-wheel, it is expedient to face it into the wind by placing it behind the tower (so-called, down-wind orientation) and to ensure anti-storm protection by blades folding up (turning) along the direction of incoming airflow (similar to umbrella folding up principle).

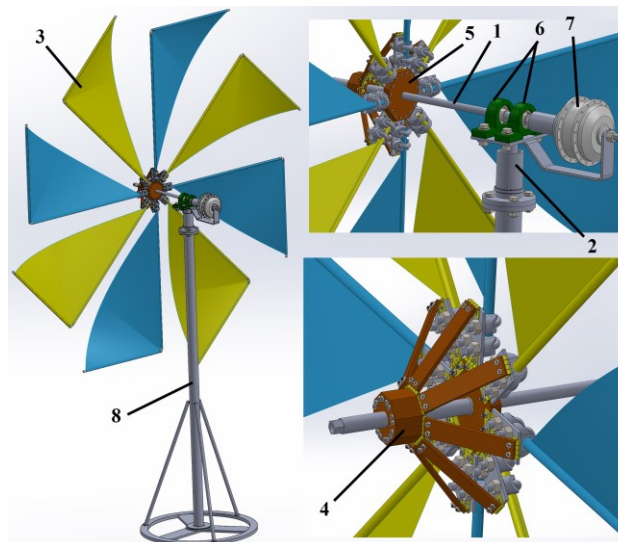

Fig. 1. Structure diagram of horizontal-axis wind-wheel with sail-blades

Wind-wheels with sail-type blades have the opportunity of self-orientation (self-facing into the wind) without the necessity of use of additional systems, which appreciate their manufacturing and complicate exploitation. The anti-storm protection mechanism 4 with rocker, connection rod and slider (in this case, the mechanism of blades folding up) requires the existence of simple and, at the same time, enough reliable spring regulator, which is used for changing of blades position depending on airflow speed and, correspondingly, for power regulation, which is generated by the wind-wheel.

III. Technique of experiment carrying out

Experimental investigations will be conducted in aerodynamic tunnel of Lviv Polytechnic National University. The wind-wheel 1 is placed in pressure zone of aerodynamic tunnel 2 and is blown by the incoming airflow of various speeds (Fig. 2). In order to measure the starting torque of the wind-wheel at various angles of blades inclination from the main drive shaft the rotary lever is rigidly attached to the main shaft by one end. The other end of the lever interacts with the dynamometer rod. The indications of the dynamometer are being read for various airflow speeds and angles of blades inclination from the plane of wind-wheel rotation. The air-flow speed is being changed by changing of rotation frequency of ventilator 3 of aerodynamic tunnel 2 and is being registered with a help of anemometer 4 (Fig. 2).

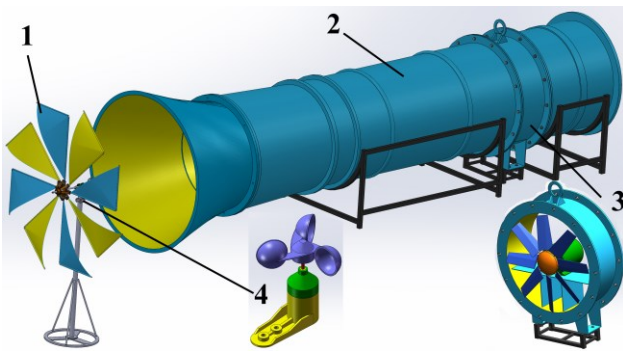

Fig. 2. Scheme of equipment placement during experimental investigations carrying out

The mechanism of wind-wheel starting torque measuring consists of rotary lever 1, which is rigidly connected by one end to the main drive shaft 2 of the wind-wheel (Fig. 3). The other end of the lever interacts with the rod 3 of dynamometer 4 (manufactured by Mitutoyo company). The dynamometer registers the value of rod 3 displacement, so we may recalculate the value of force on the rod. If the length of the rotary lever 1 is known, we may determine the torque which arises on the wind-wheel when it is starting up. The results of investigations (the dependencies of wind-wheel starting torque from airflow speed under different angles of blades inclinations) will be presented in further publications.

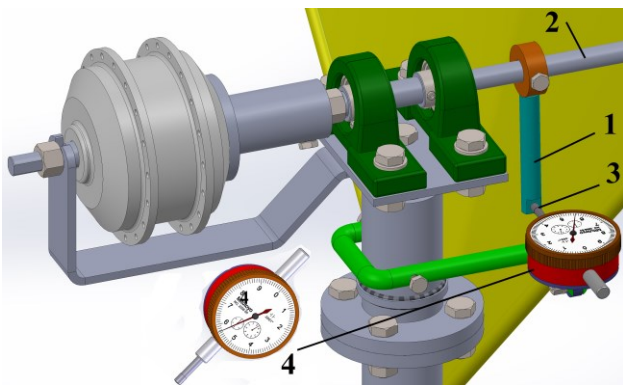

Fig. 3. Scheme of mechanism of starting torque measuring

Conclusion

The paper substantiates the expediency of usage of slow-speed multi-blade horizontal-axis wind turbines with sail-type blades in regions with low wind potential. The structure of wind-wheel is presented and its basic operational features are overviewed. In particular, it is emphasized on the prospects of use of self-orientation systems (systems of self-facing of wind-wheel into the wind) by placing the wind-wheel behind the tower (so-called, down-wind orientation). Also it is substantiated the expediency of use of mechanisms of blades folding up in order to ensure anti-storm protection and power regulation of wind-wheel.

The dependence of torque from the angle between longitudinal axis of the blade and horizontal shaft of the wind-wheel and the angle between the blade surface and the surface of wind-wheel rotation is substantiated.

The structural features of experimental prototype are overviewed and the technique of experiment replication is developed. The structure of the mechanism of wind-wheel starting moment measuring with a help of dynamometer (manufactured by Mitutoyo company) is developed.

It is necessary to emphasize on the expediency of development of complete engineering technique of calculating and designing of horizontal-axis wind-turbine as combined system, which consists of aerodynamic, mechanical and electrical sub-systems. The results of experiments presented in the paper may be used during the forming of corresponding mathematical models of wind turbine sub-systems. Also is it necessary to mention the possibilities of use of combined mechanical systems of simultaneous blades folding up and turning round their longitudinal axes as more efficient and accurate systems of anti-storm protection and power regulation of horizontal-axis wind turbines with sail-type blades [5]. In order to enlarge the incoming airflow area and direct it on the wind-wheel blades with the aim to increase the torque on the main drive shaft, it is expedient to use airflow concentrators. The presented prospects of wind turbine improvement will be investigated in further publication.

References

- [1] V. M. Korendiy, I. V. Kuzio, V. V. Vergeles, "Analysis of power regulation mechanisms of horizontal-axis wind turbines and prospects of their improvement", *Visnyk Natsionalnoho universytetu «Lvivska politekhnika»: Dynamika, mitsnist ta proektuvannia mashyn i pryladiv*, no. 788, pp. 92-100, 2014.
- [2] A. Jakovics, S. Sakipova, K. Kussainov, Zh. Kambarova, Ye. Kussainov, "Development of autonomous energy supply system using a sail type wind turbine", Proc. International conference "Advances in Environmental Sciences, Development and Chemistry," Santorini, Greece, pp. 62-66, 2014.
- [3] S. E. Sakipova, Zh. T. Kambarova, M. M. Turgunov, E. K. Kussainov, A. K. Kussainova, "Development of sail type wind turbine for small wind speeds," *Eurasian Physical Technical Journal*, vol. 10, no. 2 (20), pp. 20-25, 2013.
- [4] S. K. Tewari, Ningaiah, D. V. V. Subramanyam, A. C. Samraj, "Development of sail type wind turbine for small wind speeds," *Proceedings of the Indian Academy of Sciences. Section C: Engineering Sciences*, vol. 2, issue 1, pp. 107-116, 1979.
- [5] V.M. Korendiy, V.I. Lozynskyy, "Kinematic analysis of combined mechanical systems of simultaneous blades turning and folding of horizontal-axis wind turbines," *Avtomatyzatsiia vyrobnychyykh protsesiv u mashynobuduvanni ta pryladobuduvanni*, no. 48, pp. 38-46, 2014.