

# The simulation of the heat transfer equipment using methods of engineering analysis

Andriy Kovalchuk, Roman Pidhirnyi,  
Uliana Lesiuk, Oleksandr Ivashchuk

Department of Chemical Engineering, Lviv Polytechnic National University, UKRAINE, Lviv, S. Bandery street 12,  
E-mail: oleksandr.s.ivashchuk@lpnu.ua

*The expediency of analysis and evaluation of the heat exchange process by methods on the CAE software complexes have been shown.*

Keywords – CAE, engineering analysis, simulation, heat transfer, SolidWorks.

## I. Introduction

Energy costs for production constitute a very large part of the cost price of the final product. In the order to the high cost of energy sources, optimizing the work of heat-exchange equipment is an important application problem. Using the modern engineering analysis software we are able to analyze the work of existing devices and make adjustments to their optimization and for the next reducing of the energy costs.

## II. Model of the laboratory device

The heat transfer equipment is used in the most industrial processes. To properly design the device, we should devaluate the important parameters: heat load, hydraulic data, physical and chemical properties of the material, temperature values (starting and ending), flow chart, heat loss, degree of resistance of materials used and etc.

Using the software, it's possible to set all the necessary parameters for the process of the corresponding model of the device (Fig.1) and watch the change of these parameters with time. The substance passes through the tube, and the coolant is fed into the intertubular area. Thus, go on the process of heat exchange between the coolant and the substance.

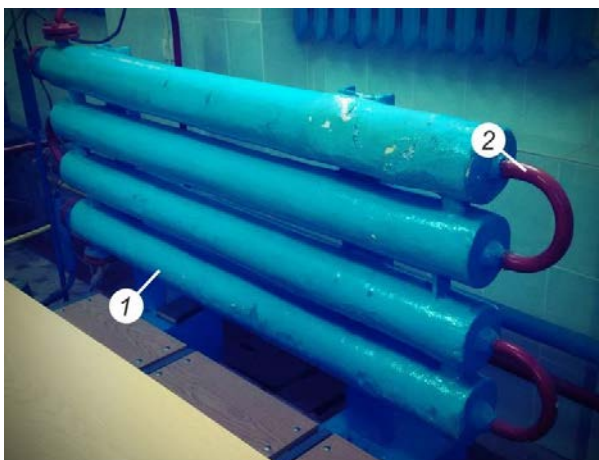

Fig.1. The laboratory «pipe-in-pipe» heat exchanger installation:  
1 – the pipe for the cool agent, 2 – the pipe for a heat agent.

For research and further modeling of the heat transfer process, experimental pilot studies have been conducted on a laboratory «pipe-in-pipe» heat exchanger installation (Fig. 1).

A solid model of the laboratory installation has been created in the CAD/CAE software complex of SolidWorks 2016 Educational Edition [1].

The solid model of the modeled «pipe-in-pipe» heat exchanger is shown in the Fig. 2.

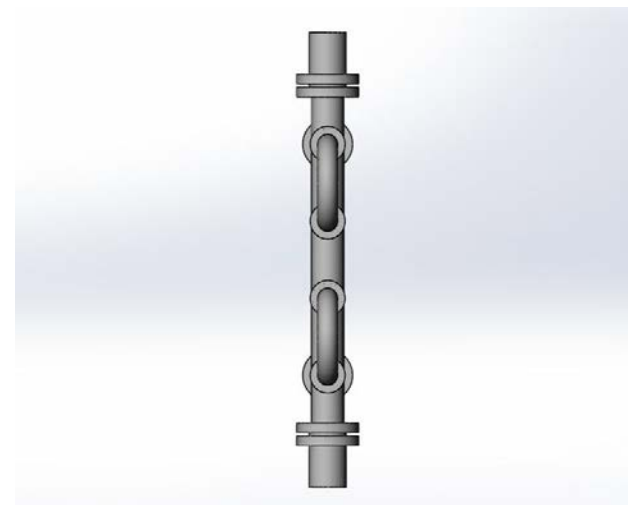
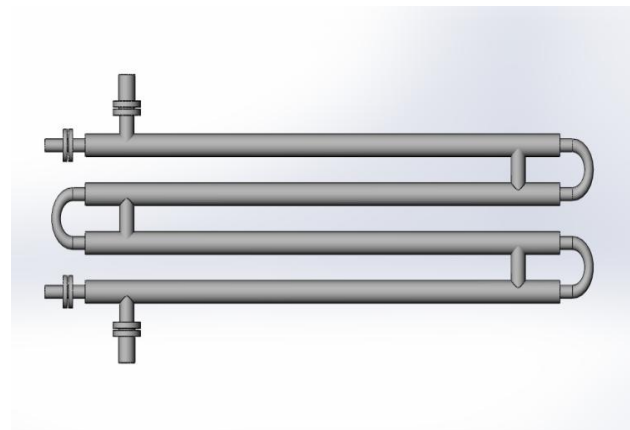
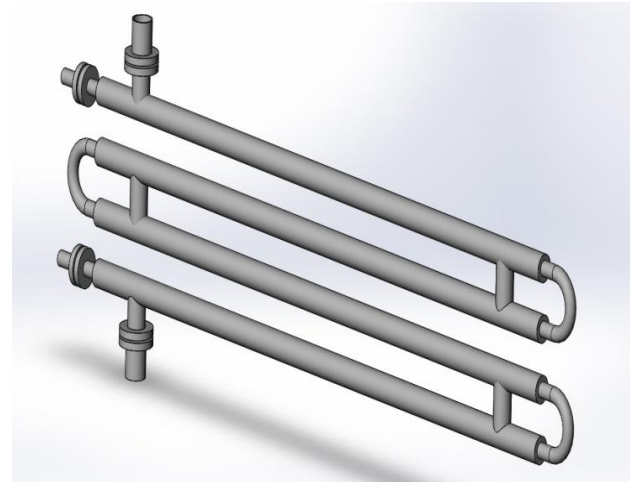

Fig.2. The «pipe-in-pipe» heat exchanger created in SolidWorks 2016 Educational Edition.

### III. Experimental part

According to the results of the test, the temperature of the cold coolant changed from 12°C to 17°C, and the hot coolant decreased from 42°C to 27°C.

By using the methods of engineering analysis the experimental data have been analyzed in the software Solidworks Flow Simulation 2016 Educational Edition.

The research results are presented in Fig. 3.

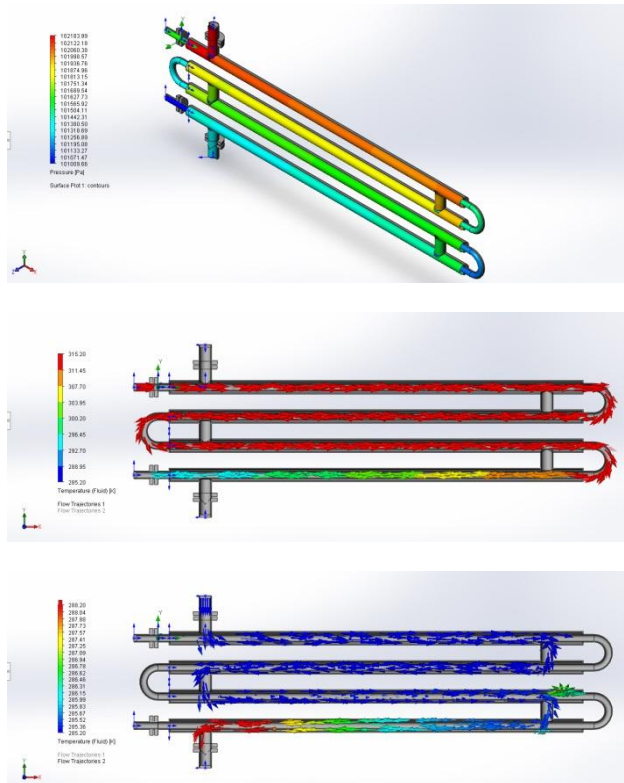

Fig.3. The analysis of the «pipe-in-pipe» heat exchanger work created in SolidWorks Flow Simulation 2016 Educational Edition.

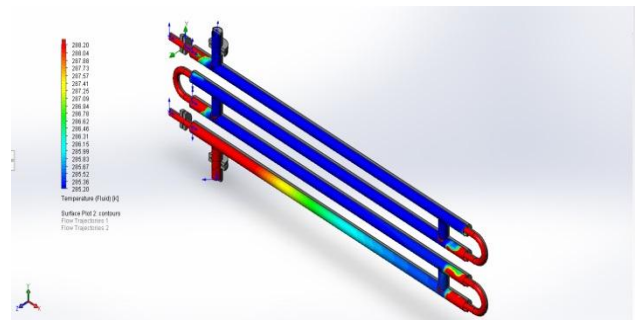

Fig.3. The analysis of the «pipe-in-pipe» heat exchanger work created in SolidWorks Flow Simulation 2016 Educational Edition.

With the help of engineering analysis methods, the practical solutions can be proposed for optimizing the existing heat exchange equipment depending on the specific needs to a particular technological process.

### Conclusions

The next research results will be published. The results are going to show simulation of the heat transfer process, which has a wide use in various industrial processes. That will help in the research of the practical process using and reducing the price on the final product.

### Acknowledgment

The authors are expressing the gratitude to the company «Intersed-Ukraine», the official representative of SolidWorks Corp. in Ukraine.

### References

- [1] Tickoo Sham. *Solidworks 2016 for Designers*. CADCIM Technologies, 2016.