

Modeling and Analysis of Processes in Synchronous Generator with PWM Controlled Excitation System

Mykola Semeniuk¹, Vasylyl Tutka²

¹Institute of Power Engineering and Control Systems, Lviv Polytechnic National University, UKRAINE, Lviv, S. Bandery street 12, E-mail: mykola.semenyuk@gmail.com

²Burshtyn Power plant, UKRAINE, Burshtyn, E-mail: TutkaVV@dtek.com

Abstract – The mathematical model of synchronous generator with PWM controlled excitation system has been developed by using mathematical modelling method. The research results of the transient and steady-state mode of generator voltage regulation are presented.

Key words – static excitation system, synchronous generator, closed loop system, automatic voltage regulator, PI voltage controller, full bridge DC/DC converter, AC/DC converter, rectifier, pulse width modulation, power system simulation.

I. Introduction

The main task of static excitation system of synchronous generator is to provide voltage stability with high accuracy [2-5, 7]. Static excitation system with semiconductor controlled rectifier (SCR) provides relative terminal voltage stability of $\pm 2.5\%$ [6]. In this paper it is offered to use full bridge DC/DC converter with pulse width modulation (PWM) for static excitation system instead SCR.

II. Static Excitation System

The power unit consists of synchronous generator with static excitation system and three power load. (Fig.1). The static excitation system includes: AC/DC converter (rectifier), full bridge DC/DC converter and automatic voltage regulator (AVR). Power scheme of the static excitation system is shown in Fig.2.

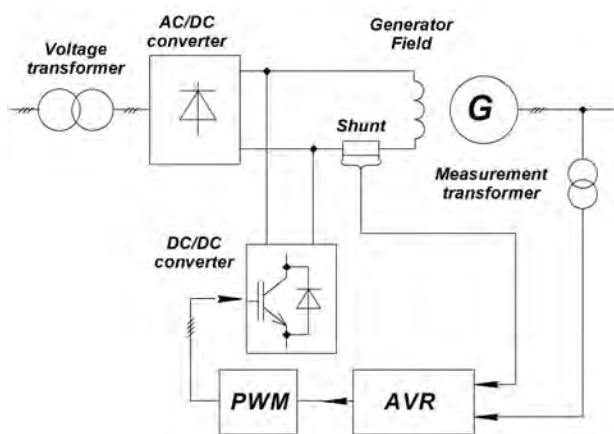

Fig. 1. The function scheme of the power unit

The closed loop system is used for the terminal voltage stability of synchronous generator (Fig.3). The actual value of synchronous generator terminal voltage is compared with an adjustable generator voltage setpoint and is taken to the input of the PI voltage controller.

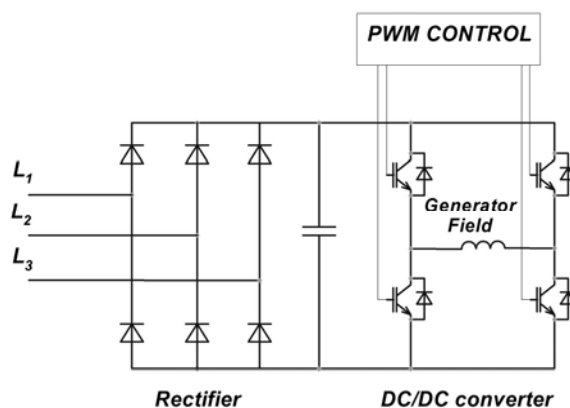

Fig. 2. The power scheme of synchronous generator excitation system

The PI voltage controller with adjustable gain and time response provides an output signal which is applied to the setpoint input I_{ref} of the secondary field current controller. The output of this controller governs the generation of frequency-modulated driving pulses for the power IGBT of associated output stage, which is operated with a clock frequency of about 1 kHz.

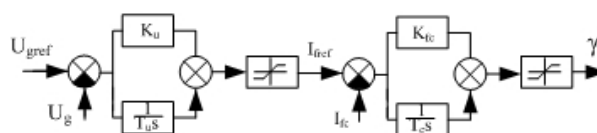

Fig. 3. The structure scheme of synchronous generator AVR

III. Mathematical Model

The mathematical model of the power unit, which includes synchronous generator, three phase power load and static excitation system, is developed using mathematical modeling method of prof. Plachtyna [1]. Power network, AC/DC converter and full bridge DC/DC converter, that are used for supply synchronous generator field, are represented in the mathematical model as a voltage supply. Excitation voltage of synchronous generator is shown in Fig.4.

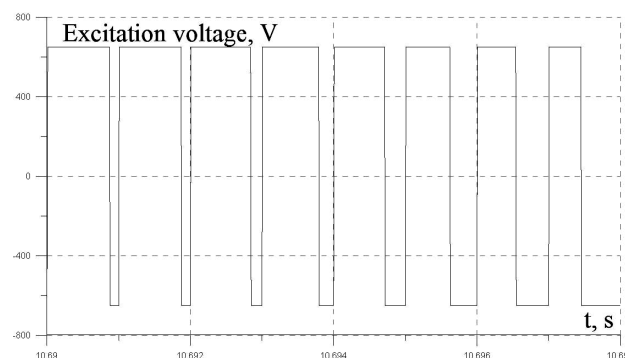

Fig. 4. The synchronous generator excitation voltage

Technical data for synchronous generator: active power 210 MW; nominal voltage – 15750 V, nominal stator current – 9060 A; no load excitation current – 715 A; nominal excitation current – 1545 A; stator resistance -

0.0024 Ω , excitation resistance - 0.174 Ω ; inductive reactances $X_d = 1.997$ RU, $X_{ad} = 1.723$ RU, $X'_d = 0.34$ RU, $X''_d = 0.223$ RU. Number of pole pairs - 1. Moment of inertia - 18500 kg·m².

Developed mathematical model of power unit works in real time. It means that computer model can be used for testing of synchronous generator excitation systems.

IV. Resaerch Results

The research results of generator switching-on to the power load with 95 % active power load are shown in Fig.5 - Fig.8.

The stator current has increased with three fluctuation and oscillation damping time is about 2.5 s in the loading mode of synchronous generator (Fig.5).

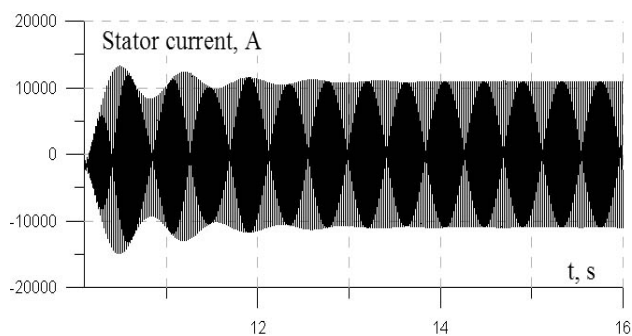

Fig. 5. The synchronous generator stator current

The terminal voltage has decreased in 1.5 % in the dynamic mode. Terminal voltage has stabilized in the steady-state (Fig.6).

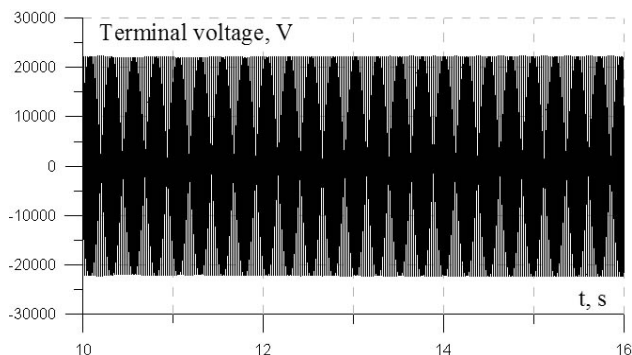

Fig. 6. The synchronous generator terminal voltage

The excitation current of synchronous generator has increased to 1500 A for stabilizing terminal voltage (Fig.7).

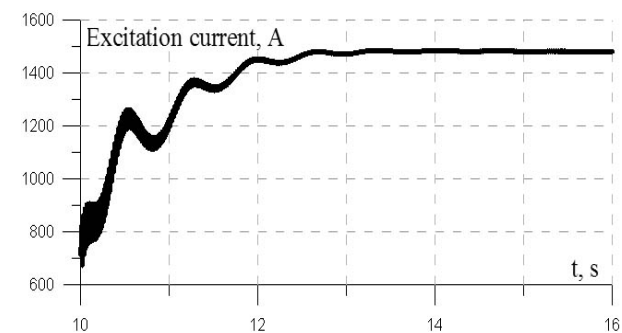

Fig. 7. The synchronous generator excitation current

Torque angle of synchronous generator has increased to 55° (Fig.8).

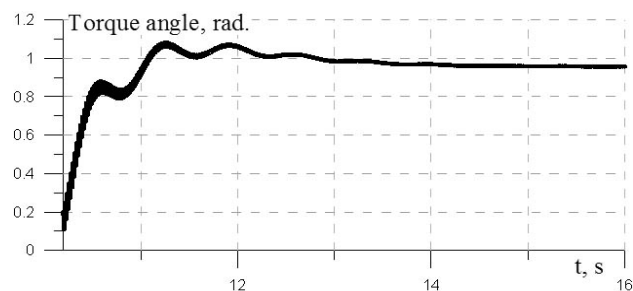

Fig. 8. The synchronous generator torque angle

Research results of processes in power unit with synchronous generation and PWM and PI automatic voltage regulator show that terminal voltage stability of synchronous generator is provided by static error circa 0 % and dynamic error - 1.5 %.

Conclusion

Static excitation system of synchronous generator with PWM regulation of excitation current provides high accuracy of terminal voltage stability through better quality of field generator current than SCR excitation regulation.

PWM controlled excitation systems of synchronous generator are recommended to be used instead of SCR excitation systems because of high regulation characteristics.

References

- [1] E. G. Plakhtyna, "Matematicheskoe modelirovanie elektromashinno-ventil'nykh sistem" ["Mathematical modeling electrical machine and gate systems"], Lviv, Ukraine: Lviv university Publ., 1986, 161 pages.
- [2] R. C. Schaefer, "Voltage regulator influence on generator stability," in Basler Electric Power Control and Protection Conf., St. Louis, MO, 2003.
- [3] R. C. Schaefer, "Application of static excitation systems for rotating exciter replacement", in Proc. IEEE Pulp and Paper Industry Tech. Conf., Cincinnati, OH, USA, 1997, pp.199-208.
- [4] Compound-Excitation System for Synchronous Generators, Siemens AG Power Generation, 2004.
- [5] S. Cholewa and Z. Janson, "Nowoczesne układy wzbudzenia i regulacji napięcia generatorów synchronicznych", Wiadomości Elektrotechniczne, No.4, 2000, pp.197-201.
- [6] V. V. Tutka, "Systemy zbudzenia heneratoriv Burshtynskoi TES ta yikh modernizatsiia" ["Synchronous generator excitation system of Burshtyn power plant and their modernization"], Elektroenerhetychni ta elektromekhanichni systemy - Electricity and electromechanical systems, No.615, pp.182-190, 2008.
- [6] M. B. Semeniuk, "Heneratorna ustanovka z fazovym kompaunduvanniam" ["Generator unir with phase compound"], in Conference of Young Scientists Electric Power Engineering and Control Systems, EPECS, Lviv, Ukraine, 2010, pp.36-37.