

## WASTE WATER HEAT RECOVERY SYSTEM

© Markovič G., Vranayová Z., Káposztasová D. 2016

Після систем опалення та охолодження, системи гарячого водопостачання є другим за величиною споживачем енергії в домашніх умовах. Є багато потреб і використання гарячої води в будинках: душові кабінки, ванни, раковини, посудомийні і пральні машини тощо. У більшості випадків гарячі стічні води скидаються безпосередньо в систему каналізації. Якщо врахувати всіх споживачів в домашньому господарстві, стічні води зберігають значну частину своєї первісної енергії – енергії, яку можна залучити і використати. Холодну воду, яка міститься в водогрійному пристрої, можна попередньо нагріти за допомогою утилізованої теплової енергії, наприклад, водою після душу. Температура води, яка надходить в бак для гарячої води, як правило, близько 12 °С, а при використанні енергії від гарячої води з ванної або посудомийної машини температуру води, що надходить в збірний резервуар, можна збільшити до 23–25 °С. Установка систем рекуперації тепла стічних вод знижує споживання енергії і, отже, викиди парникових газів та загальну енергетичну залежність домашнього господарства. Є два основні способи отримання тепла від стічних вод з усіх джерел в будівлі: використання регенератора з подвійними стінками або нерегенеративний – з використанням простого теплообмінника. Теплообмінники системи кожного типу доступні для використання в будівлях. У цьому документі міститься короткий огляд системи утилізації тепла стічних вод як спосіб зниження загального споживання енергії в будівлі, а також сталий спосіб уловлювання та рекуперації тепла в будівлі.

**Ключові слова:** теплообмінник, тепло, відновлення, стічні води.

After heating and cooling, water heating is typically the second largest user of energy in the home. There are a lot of purposes and uses of hot water in buildings - showers, tubs, sinks, dishwashers and clothes washers etc. In most cases, these hot waste waters are discarded direct to sewer system. When we take into the account all of these purposes in every households, the wastewater retains a considerable portion of its initial energy – energy that could be recovered and used. The cold water that is put into a water heating device can be preheated using the reclaimed thermal energy from a appliance such a shower so that the input water doesn't need as much energy to be heated before being used in a shower, dishwasher, or sink. The water entering a hot water tank is usually close to 12 °C but by recovering the energy in the hot water from a bath or dishwasher, the temperature of the water entering the holding tank can be elevated to 23–25 °C. Installing a waste water heat recovery systems reduces energy consumption and thus greenhouse gas emissions and the overall energy dependency of the household. There are two basic ways how to capture heat from wastewater produced by all sources in a building and to put it to use - require a regenerator-type double-walled heat exchanger or a non-regenerative, straightforward heat exchanger can be used. Heat exchanger systems of each type are available for use in buildings. This paper contains brief overview of the waste water heat recovery system as a way of reducing of overall energy consumption in building as well as sustainable way of capturing and recovering heat within the building.

**Key words:** exchanger, heat, recovery, waste water.

**Introduction.** The cost of energy required to heat water in buildings is one of the biggest energy fees at home after cooling and heating, and considering that most of that energy essentially gets wasted by flowing

down the drain. There are a number of uses of hot water in buildings (Fig. 1). Typical activities in every building as a showers, tubs, sinks, dishwashers and clothes washers have a potential of effectively recapture some of that energy. These drain water heat recovery systems we also known as drainline or gravity film heat exchangers. These exchangers capture energy from waste water and use it to preheat supply water. These systems are typically installed in the basement as part of the drainage stack, the systems lead to either a hot water tank or to an appliance that concurrently uses hot water and produces warm wastewater, such as a shower [1].

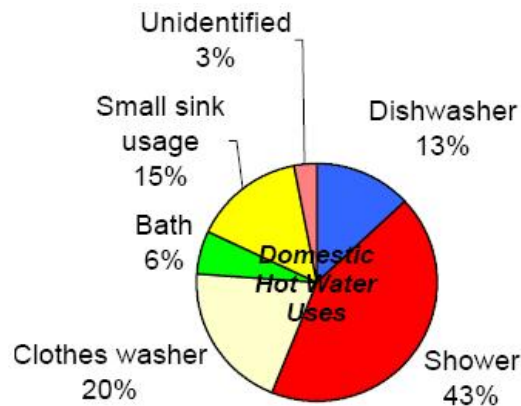

Fig. 1. Uses of hot water in buildings [2]

**Drain water heat recovery systems.** Selecting of the installation method is a compromise between the various requirements relating to energy efficiency and performance of the installation. The big advantage for the application of these systems is application in the new buildings. Process of drain water heat recovery system is depicted on Fig. 2.

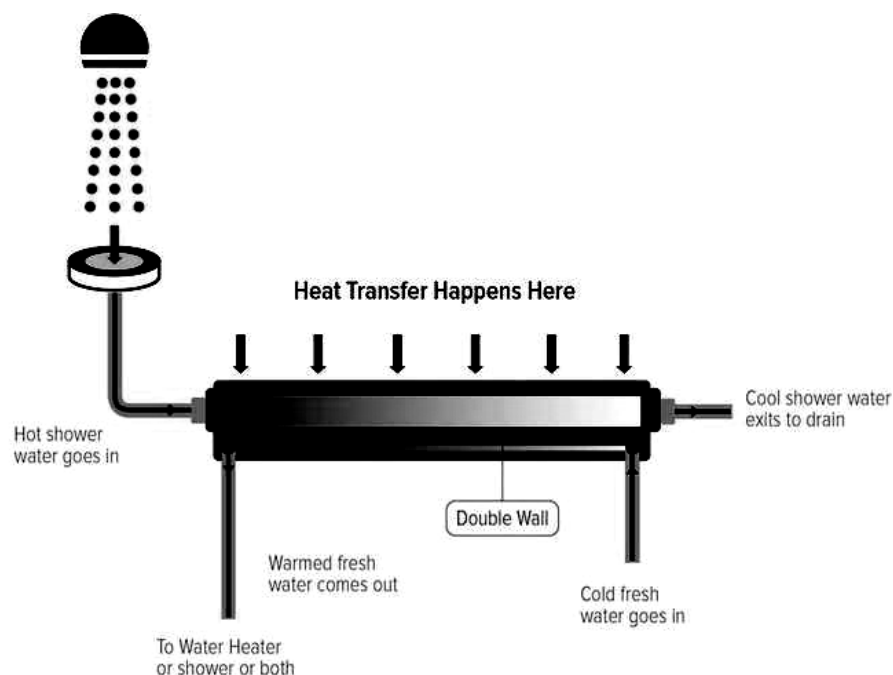

Fig. 2. Process of drain water heat recovery [6]

In generally, there are two basic methods of recuperation from waste water:

- Preheat of cold water for immediate consumption – Fig. 2
- Preheat of cold water combined with domestic hot water tank – Fig. 3

Preheat of cold water for immediate consumption:

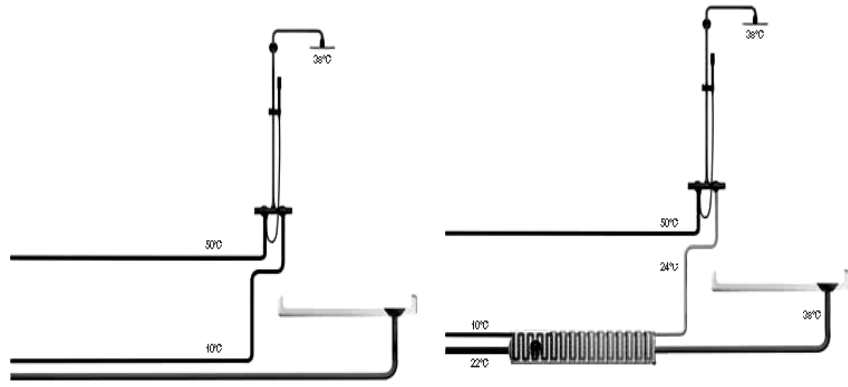

Fig. 3. Preheat of cold water for immediate consumption [3]

The advantage of this connection type is that the pre-heating process is still during the water consumption. Dwell time, when the preheated water is available, is dependent on the length and location of the pipeline and recuperation panel. This water can be directly connected to the circuit of showers, sinks, etc. This measure has the reducing effect of hot water consumption. As a result, there is a smaller proportion of hot water against proportion of preheated water in a mixer tap [3].

Preheat of cold water combined with domestic hot water tank:

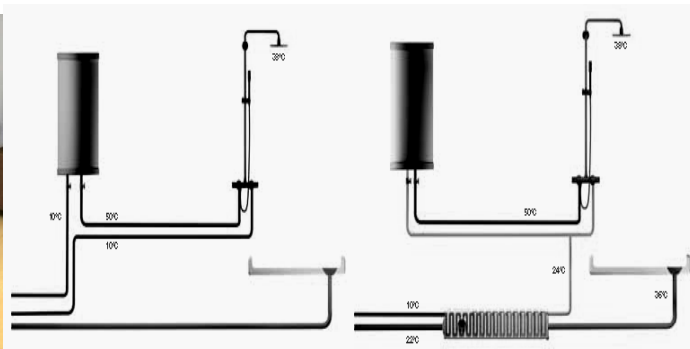

Fig. 4. Preheat of cold water combined with domestic hot water tank [3]

The second option is to lead preheated water into the pipe connecting the reservoir TV with various appliances. This installation connection represents the maximum of energy savings for drain water heat recovery systems. Pipe with preheated water must be still very well insulated against the heat losses [4, 5].

The basic requirement for these systems is that the heat exchanger have to be the closest to appliances of which utilize waste heat.

Possibilities of connections for drain water heat recovery systems are depicted on fig. 5 and 6.

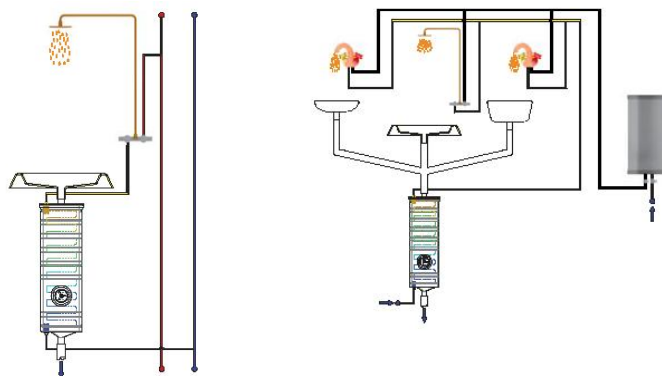

Fig. 5. Direct connection to one and more appliances [3]

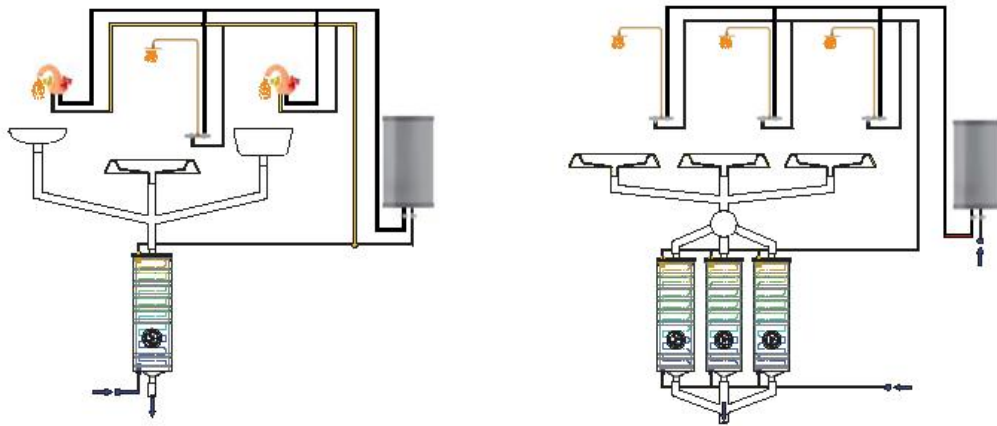

Fig. 6. Combined connection with DHW and direct parallel connection to appliances [3]

**Conclusion.** Energy, which is required to heat domestic water may be reduced by preheating with waste heat from drainlines. Appliances from bathroom, kitchens and laundries offer the greatest opportunities for this type of heat recovery. Especially appliances from kitchens and laundries provide fairly high water temperatures and schedules are predictable.

The drain water heat recovery systems is a simple and effective method for significantly reducing the energy needed to produce hot water. Heat recovery from waste water will be more and more important due to rising energy prices for reducing of the energy intensity.

**Acknowledgements.** This work was supported by the VEGA 1/0202/15 Sustainable and Safe Water Management in Buildings of the 3rd. Millennium.

1. Moore H., 2013, *Drain Water Heat Recovery Systems are Energy Efficient and Economical*, *Eco Building Pulse Magazine*, Online: <http://www.ecobuildingpulse.com/author/heidi-moore>. 2. Tomlinson J. J. *Heat 2001 Recovery from Wastewater using a Gravity-Film Heat Exchanger Federal Energy Management Program*, Energy Division Oak Ridge National Laboratory. 3. Ivar.cz, online: <http://vytapani.tzb-info.cz/uspory-vytapani/9729-domovni-a-bytove-rekuperacni-panely-ivar-bee-usnadnuji-cestu-k-vasim-energetickym-ustoram>. 4. "Heat Exchangers in Aggressive Environments," Center for the Analysis and Dissemination of Demonstrated Energy Technologies (CADET), Analysis Series #16, 1995. 5. Vasile, C. F., "Residential Waste Water Heat Recovery System: GFX," Center for the Analysis and Dissemination of Demonstrated Energy Technologies (CADET), No. 4, December 1997. 6. Markham D., *Next-generation heat exchanger recovers heat from shower drains to preheat water Technology / Clean Technology*, June 20, 2014.