

## STABILITY ISSUES IN MODERN POWER SYSTEMS

Oleksandr Kyrylenko, Vsevolod Pavlovskiy,  
Lukian Lukianenko, Anton Steliuk, Oleg Lenga

Institute of Electrodynamics of National Academy of Sciences, Kyiv, Ukraine

*Lukianenko.Lukian@gmail.com*

© Kyrylenko O., Pavlovskiy V., Lukianenko L., Steliuk A., Lenga O., 2015

**Abstract.** In the paper, the important issues of the power system stability have been considered. The theoretical backgrounds of small-signal stability analysis for power systems studies and its application for validation of power system dynamic models using transient stability are presented. The considered example of dynamic models validation uses procedures based on the both small-signal stability analysis and time domain simulation.

At present, in Ukraine, the activities are held to provide the synchronous operation of the national IPS with European grid ENTSO-E. It requires solving of numerous tasks including the frequency stability and export power flow control in order to provide a flexible control of the IPS operation. In particular, including a DC link in the “Burshtyn island” interface in most cases will improve a reliable schedule implementation to ENTSO-E and will increase the reserve capacity at Burshtyn thermal power plant.

Taking into account the stated above, the frequency stability of the IPS of Ukraine has been studied considering DC link connecting Khmelnytskaya nuclear power plant and Rzeszow substation. In order to simulate long-term dynamics, the detailed model has been developed including the automatic power controller of “Burshtyn island”, automatic generation controllers of IPS of Ukraine and unified power system of Russia, DC link control system and ENTSO-E border area models. The frequency control simulation is performed in the event of generating unit disconnection at Burshtyn thermal power plant.

The obtained simulation results show that modern DC link application provides a flexible regulation of the export power flows in AC/DC hybrid power systems to control the reserve capacity of Burshtyn TPP. Due to the active power flexible regulation by modern DC link, it becomes possible to use the secondary reserves controlled by the national automatic generation controller for “Burshtyn island”.

**Key words:** low-frequency oscillations, small signal stability, methodology of study, frequency stability, interconnection to ENTSO-E.

### 1. Introduction

Several years ago, transmission system operators (TSO) of Ukraine and Moldova requested for a syn-

chronous interconnection to the system of the Regional Group Continental Europe of European Network of Transmission System Operators for Electricity (ENTSO-E). The Consortium of European TSOs has been formed in order to elaborate the “Feasibility Study on Synchronous Interconnection of the Ukrainian and Moldovan Power Systems to ENTSO-E”. The main objectives of the feasibility study is to investigate the possibility of the Ukrainian and Moldavian power systems to operate in parallel with the Continental European Synchronous Area respecting its and ENTSO-E technical operational standards.

It should be noted that the technical operational standards used in ENTSO-E and Ukrainian/Moldovan (UA/MD) power systems are quite different. At the same time, any technical operational standards in any power systems are based on the well-known power engineering principles. However, there is still a gap between the engineering practices used for stability analysis in ENTSO-E and in our Ukrainian system. In order to understand the particularities and practices used for power system studies at ENTSO-E, it is of paramount importance to exhibit some aspects of the theory of stability and its applications.

This article deals with three very important kinds of the power system stability. It includes the theory of small-signal stability analysis and application of this theory to the validation of power system’s dynamic models using transient stability. Taking into account the SuperGrid formation in European countries and the integration of the interconnected power system (IPS) of Ukraine to ENTSO-E, in particular using the direct current (DC) technologies allowing an increase in the export power flows, the frequency stability study is an important task as well.

### 2. Theoretical background of small-signal stability analysis and methodology of its study

The majority of power system components, such as generators, excitation systems, governors and loads, have nonlinear characteristics. These components and their associated controls may include saturation and output limiters. Despite the fact that the theory of nonlinear systems can be used to study such a system, it is applicable only for small and simple systems.

On the other hand, the theory of linear systems can provide useful insights into the operating behavior of an interconnected power system. The use of this theory is based on the principle that the dynamic behavior of the system is linear (or quasi-linear) in the neighborhood of its equilibrium point. Fortunately, low frequency oscillations in a power system are fairly linear when caused by disturbances of a small magnitude such as random fluctuations of generation and load. The variations in system dynamic variables such as a machine rotor angle and speed are also small under these circumstances and the assumption of linearity of the system model in the neighborhood of a given operating point provides valid results.

In the traditional “Russian school” of power system analysis, there were not significant achievements in practical methods and tools of small-signal stability investigation. The main attention was paid to study of aperiodic steady-state (static) stability and transient (dynamic) stability of synchronous machines. An exception case was the oscillation stability described in [1]. However, a very small test system has been used in that paper to demonstrate the modal analysis techniques.

The advantage of accepting a linear model for the system analysis is that the theory of linear systems is in the mature state, meaning that methodologies, algorithms, and tools, able to deal with very large systems in reasonable computation time, are available.

In power systems, the study of system stability using linear models is commonly referred to as “small-signal stability analysis”. This type of study allows the analysis of so-called steady-state stability. The following types of oscillation modes can be detected and identified through the small-signal stability analysis [2]:

- *Local modes*: associated with the oscillations of units at a power station with respect to the rest of the system (oscillation frequency between 1 Hz and 2 Hz). These oscillations are located at one station or in a small part of the system.

- *Inter-area modes*: associated with the swing of many machines in one part of the system against machines in the other parts (oscillation frequency between 0.1 Hz and 1 Hz). Caused by two or more groups of coherent (electrically close) machines being interconnected by a weak transmission network.

- *Control modes*: associated with generating units and their controls. The usual causes of instability in such modes are improperly tuned excitation systems, speed governors, high voltage direct current (HVDC) converters, and static voltage controllers (SVC).

- *Torsional modes*: associated with the rotational components of turbine-generator shaft systems. The usual causes of instability in such modes are interactions of the mentioned systems with excitation controls, speed governors, HVDC controls, and series-compensated lines.

It must be emphasized that stability in small-signal sense is a necessary (but not sufficient) condition for power system operation. As consequence of not being a sufficient condition, the results of small-signal stability analysis must be assessed through nonlinear time-domain simulations (electromechanical transient simulations).

The first step for the small-signal stability analysis is the linearization of a power system dynamic model in the neighborhood of a given operating condition. The linearized system is then used to compute the following parameters:

- *System eigenvalues and eigenvectors (both right and left);*
- *Participation factors;*
- *Controllability and observability indices.*

Critical oscillation modes are defined as modes with a low damping level (the International Council on Large Electric Systems (CIGRÉ) recommends a minimum damping of 5% on electromechanical oscillations in power systems). The identification of critical oscillation modes starts with the computation of the system eigenvalues. As the power system model is very large, the computation of all system eigenvalues through the orthogonal decomposition-based methods (i.e. QR factorization) is not recommended due to the large computational time and memory usage required by these methods [3].

Inter-area modes are pre-identified by selecting the modes the frequency of which lies in the range between 0.1 Hz and 1 Hz. To come to the final decision on which modes actually the inter-area modes are, a further step is needed: an analysis of the mode shapes, which is explained afterwards.

The goals of the participation factor and the mode shape analysis are twofold: to identify the machines associated to the critical oscillation modes (analysis of participation factors) and the inter-area modes, within the modes with frequency between 0.05 Hz and 2 Hz. The participation factors provide an indication of the contribution of the machines to a given mode. This is very useful for identifying the machines that make major contributions to the critical modes, as well as to the inter-area modes. In this study, the participation factors of all modes classified as critical (damping  $\zeta < 5\%$ ) in the eigenvalue computation phase are calculated and analyzed in order to provide indications on the machines

that take the most active participation in the critical modes.

The mode shapes give the relative magnitude and the phase of the oscillations for a given state variable. Since the objective of this project is to analyze electromechanical oscillations, the rotor speed or angle must be chosen as a state variable.

In many power system studies, the mode shapes out of all oscillation modes with frequency between 0.05 Hz and 2 Hz are calculated and analyzed in order to identify all inter-area modes. Having identified these modes, their respective damping ratios are carefully analyzed. In case of poorly damped inter-area modes, the necessary measures to improve the damping are recommended.

### 3. Automatic voltage regulator models and validation of the dynamic model of IPS of Ukraine

One of the very interesting applications of the small-signal stability analysis is the validation of power system's dynamic models. In general, the time domain simulation is mainly used for the analysis of dynamic models' performance. The idea is to show that the small-signal stability analysis may contribute to the results obtained from the time domain simulation and vice versa. The following practical example gives a bright application of the both approaches (for example, the latest model of IPS of

Ukraine in DigSILENT PowerFactory which is used by the Ukrainian TSO for different projects. Lately, these models were used for the Ukrainian and Moldovan Power Systems Integration (UMPSI) project).

For verification purposes, it is necessary to take several steps presented below:

- The base case model of the IPS of Ukraine has been chosen for comparison.
- The above-mentioned model of the IPS of Ukraine has been tuned. The following points have been checked:
  - a. network configuration (220 - 750 kV lines)
  - b. 750 kV shunt reactors' configuration
  - c. active power generation of nuclear power plants (NPP) and thermal power plants (TPP).

Fig. 1 shows an automatic voltage regulator (AVR) model (AVR-SD type). The following denotations are used:  $u$ ,  $u_{set}$  are the signal and setpoint of the voltage generator;  $f$  is the generator bus frequency;  $cur_{ex}$  stands for the current excitation generator signal;  $K_{OU}$ ,  $K_{IU}$ ,  $K_{OF}$ ,  $K_{IF}$ ,  $K_{IF}$  are the gains of regulator channels;  $T_{OU}$ ,  $T_{OF}$ ,  $T_{IF}$ ,  $T_{IF}$ ,  $T_{BCH}$ ,  $T_{okr}$  represent the time constants of regulator channels;  $T_{voz}$  denotes the time constant of the exciter;  $VOEL$  is the signal from the over excitation limiter (OEL).

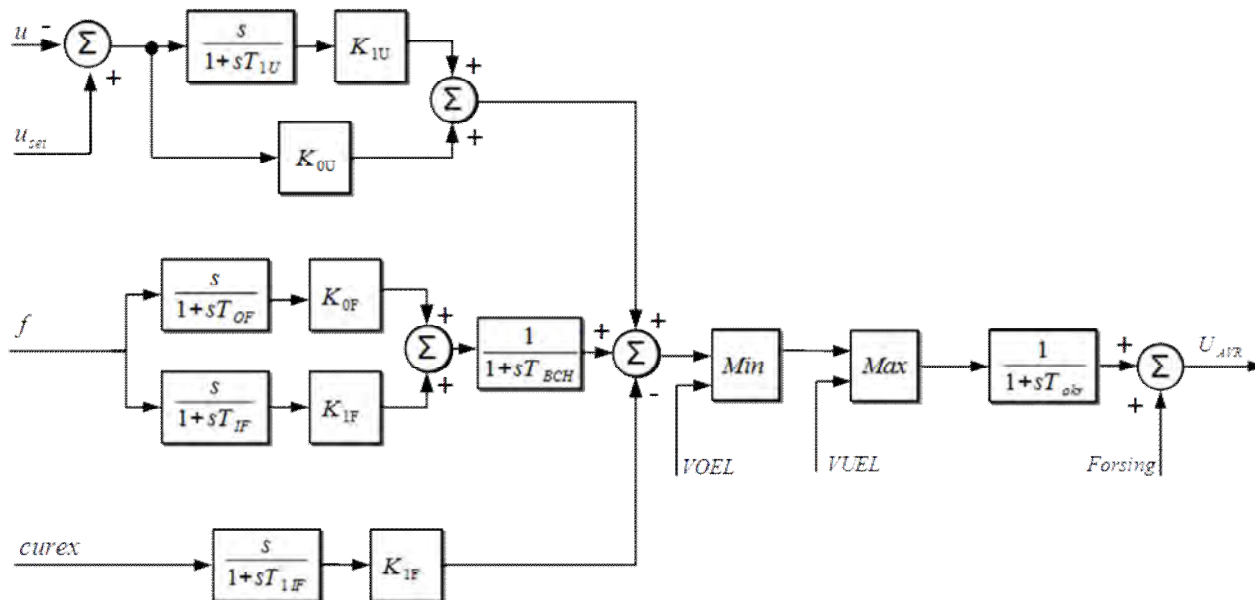

Fig. 1. AVR model for 1000MW NPP units.

This section presents the results of a small-signal and transient stability analysis. The results of the small-signal stability analysis show that there is an inter-area mode with poor damping (see Fig. 2 and 3). Fig. 2 shows governor speeds (one of controllability indices) for

chosen plants. The poorly-damped mode corresponds to the oscillations of Zaporizka nuclear power plant (NPP) against the oscillations Khmelnytska and Rivnenska NPPs (Fig. 4, a), hereafter named as “ZNPP vs KNPP and RNPP” mode.

In the case of critical inter-area modes, the identification of the candidate machines for AVR parameters retuning is performed. The choice of the machine and the input signals to be used for improving the damping of critical modes is not straightforward. It depends

on the calculation of controllability and observability indices [2]. In this study, if any critical inter-area mode is detected at a certain operating condition, the necessary recommendations for the AVR parameters retuning are given.

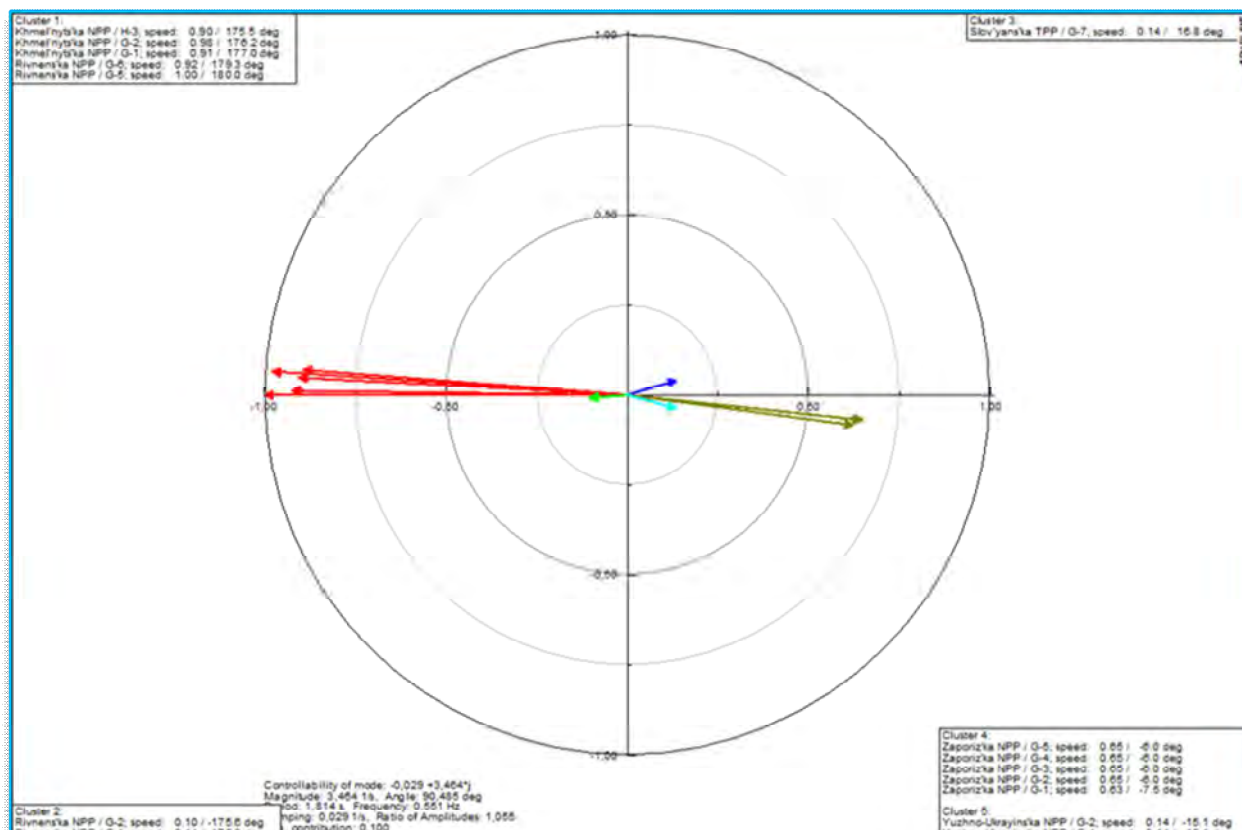

Fig. 2. Controllability indices for the chosen plants in a critical mode.

After scrupulous analysis of the date and the model, it has been found that the AVR settings at the nuclear units of 1000 MW play a significant role in the “ZNPP vs KNPP and RNPP” inter-area oscillations. The AVR settings for all 1000 MW NPP units have been double-

checked taking data from all the sources available. The updated AVR settings for 1000 MW units are presented in Table 1.

Moreover, the damping of eigenvalues (0.5 – 1 Hz frequency range) has been improved (Fig. 3).

Table 1

**Updated AVR settings for NPP units**

Power plant	Khmelnytska NPP		Zaporizka NPP	Pivdenoukrainska NPP		Rivnenska NPP	
	1	2,4	1-6	1-2	3	3	4
K0U	19.84	19.6	25	25	25	25	25
K1U	2.36	1.73	1.5	3.75	2.88	1.64	1.73
K0F	2.24	1.9	7.5	1.5	1.44	1.22	1.44
K1F	0.83	0.796	2.5	1	1.152	1.9	2.3
K1IF	2.17	1.57	2.16	2.16	2.16	1.54	1.62

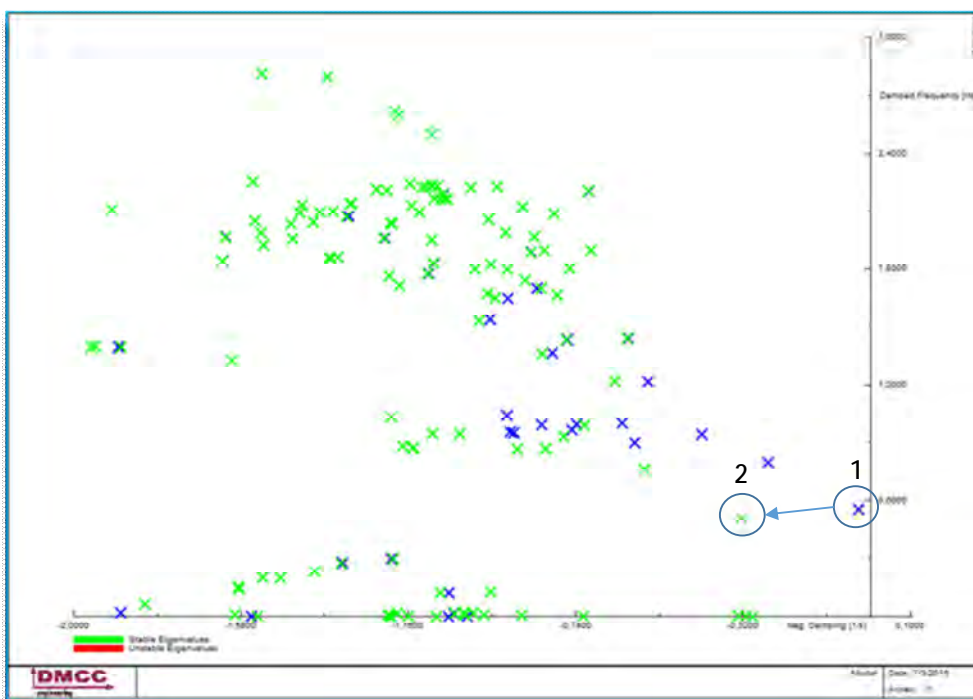

Fig. 3. Eigenvalues for two sets of AVR setting (blue color – for standard settings, green color – for updated settings).

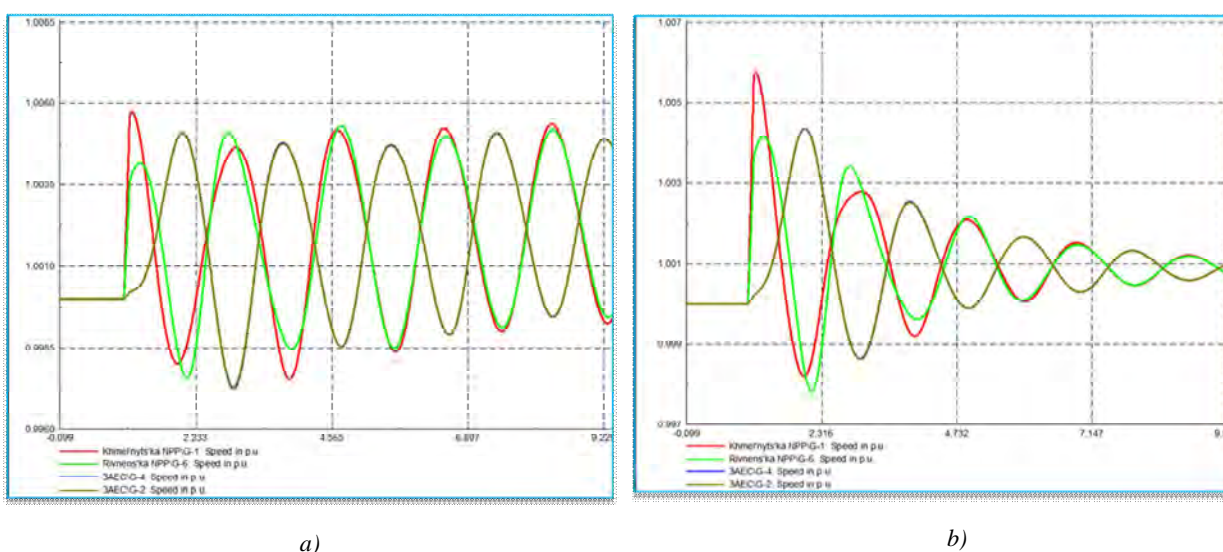

Fig. 4. Results of time-domain simulations of a critical mode for two sets of AVR settings.

Fig. 4 presents the results of the time-domain simulations that clearly depict the “ZNPP vs KNPP and RNPP” inter-area mode after modifying the AVR settings at 1000 MW units.

The theory of small-signal stability is the practice useful for tuning and validation of models. The results of the analysis show the necessity of a preventive measure for the damping of oscillations in an inter area within Ukraine for the scenario of parallel operation with the ENTSO-E power system.4. Frequency stability and

flexible automatic generation control for embedded HVDC links

Future energy systems networks will completely differ from the actual power systems. High- and low-powered converters will be massively deployed in several areas of the electric network: (i) renewable energy from highly variable generators connected over high-powered converters, (ii) several technologies for energy storage with very different time constants, some of them using power converters as an interface to the



grid, and (iii) Pan-European transmission network facilitating the massive integration of large-scale renewable energy sources and transportation of electricity based on underwater multi-terminal high voltage direct current transmission. The developments of the stronger interconnections and the massive integration of offshore wind power in remote locations are steadily increasing the demand for more robust, efficient and reliable grid integration solutions. The multi-terminal direct current (MTDC) technology has the potential to increase transmission capacity, system reliability, and electricity market opportunities.

The integration of HVDC links into transmission systems has the potential to develop a powerful new tool for controlling both over and under frequency conditions. The high degree of controllability inherent to the active power flow on HVDC links allow rapid changes of power flows to be used to counter active power imbalances. Thus, providing the frequency stability in the power system taking into account the HVDC technology is an important and actual task. Frequency stability determines the ability of a power system to restore its normal frequency in the event of the imbalance occurrence.

Primary frequency control using the HVDC has been a hot topic during recent years. Several publications were devoted to the development and testing of the controllers in order to enable the HVDC systems to provide an inertial response to frequency deviation [4]. The HVDC for the primary frequency control has been considered in several publications [5]. However, secondary and tertiary frequency control considering the HVDC or MTDC systems was given a very low attention in recent publications.

The frequency control in power systems comprises usually the primary and secondary control. A future power system will require an active participation of the HVDC to support the primary and secondary frequency control.

The frequency control can be considered to be one of the most crucial aspects of ancillary services. It is responsible for the operation of the power system within acceptable frequency limits. The classical approach to the frequency control can schematically be divided into three stages: primary, secondary and tertiary control. This is a tiered approach where the controllers are responsible for frequency containment, frequency restoration, and replacement reserves, respectively.

The primary control refers to the control actions that are done locally (at the power plant level) based on the setpoints for frequency and power. The objective of the primary control is to maintain the balance between generation and consumption in order to stabilize the post-disturbance frequency.

The primary frequency controllers are typically simple proportional controllers. The generating unit participating in the primary control uses a proportional constant in the controller, named speed droop  $D$ . The constant provides a relationship between a momentary frequency deviation ( $\Delta f$ ) and a change in electric power production ( $\Delta P$ ),  $D = \Delta f / \Delta P$ , measured in Hz/MW.

The post-disturbance steady-state frequency differs from the nominal frequency, especially because the droop characteristics in the primary controllers and the load self-regulation effect. The secondary frequency control, also called Load Frequency Control (LFC), adjusts power setpoints of the generators in order to compensate for the remaining frequency error after the primary control has acted.

The purpose of the secondary control actions is to restore the system frequency to the nominal setpoint, and ensure that any tie-line flows are at their contracted level. The global analysis of the power system markets shows that the automatic generation control (AGC) is one of the most profitable ancillary services at these systems.

The AGC is the controller created for the following functions: (i) to maintain the frequency at the setpoint value (frequency control); (ii) to maintain the net power interchanges between neighboring control areas at their scheduled values (tie-line control); and (iii) to maintain power allocation among the units in accordance with the area dispatching needs (energy market, security or emergency).

Based on the above objectives, two variables – frequency and net power interchange – are combined and used in a supplementary feedback loop [6]. A suitable linear combination of the frequency ( $\Delta f = f_{meas} - f_{ref}$ , where  $f_{meas}$  is the measured power system frequency;  $f_{ref}$  is the setpoint frequency) and net power interchanges ( $\Delta P_{tie} = P_{tie} - P_{tie,ref}$ , where  $P_{tie}$  is the current net power interchange;  $P_{tie,ref}$  is the setpoint net power interchange) is known as the *Area Control Error* (ACE):

$$ACE = -\Delta P_{tie} + I_R \Delta f \quad (1)$$

where  $I_R$  is a bias factor measured in MW/Hz. The ACE corresponds to the power by which the total area power generation must be changed in order to maintain both the frequency and net interchange power at their setpoint values. The AGC is a central frequency regulator, which uses an integrating element in order to remove any error; the integrator may be supplemented by a proportional element. For such a proportional-integral (PI) regulator the output signal is:

$$\Delta P_{ref} = K_P ACE + K_I \int_{t_1}^{t_2} ACE dt \quad (2)$$

where  $K_P$ ,  $K_I$  are proportional and integral gains of PI controller;  $t_1$ ,  $t_2$  are integration limits.

The aim of the frequency bias factor  $I_R$  is to fully compensate for the initial frequency response of the area. The regulator in an area tries to restore the frequency and net tie-line interchanges after an active power imbalance, so it enforces an increase in the generation equal to the power deficit. The regulation is executed by changing the power output of power plants in the area through varying the reference signal in their governing systems.

The regulator output signal  $\Delta P_{ref}$  is then multiplied by the participation factors  $\alpha_1, \alpha_2, \dots, \alpha_n$  which define the contribution of the individual generating units to the total generation control as shown in Fig 5.

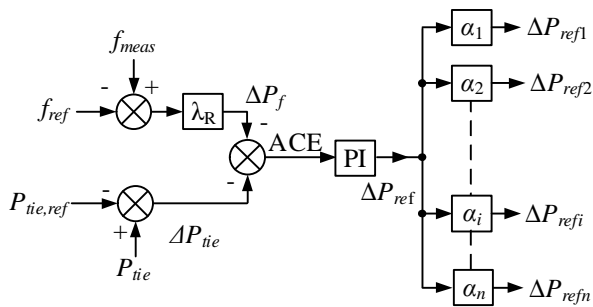

Fig. 5. The functional diagram of a central regulator.

The control signals  $\Delta P_{ref1}, \Delta P_{ref2}, \dots, \Delta P_{refn}$  obtained in this way are then transmitted to the power plants and delivered to their governing systems.

The structure of the AGC of an interconnected power system is shown in Fig. 6. It consists of  $n$  power plants with the generating units participating in frequency support.

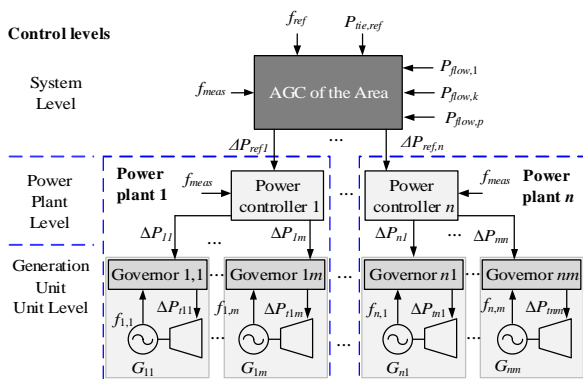

Fig. 6. The structure of an interconnected power system and representation of the AGC.

There are three control levels of the active power and frequency control. The upper system control level is presented by the AGC of the area (system level). The input signals are: the measured system frequency  $f_{meas}$ , the setpoint frequency in the power system  $f_{ref}$ , the

measured tie-line flows  $P_{flow,k}$ ,  $k = \overline{1, p}$ , where  $p$  is the number of tie-lines, and the setpoint net power interchange  $P_{tie,ref}$ .

Based on the tie-line interchanges  $P_{flow,k}$ , the net interchange power  $P_{tie}$  is calculated as:

$$P_{tie} = \sum_{k=1}^p P_{flow,k} \quad (3)$$

Further, an area control error  $ACE$  as well as the output signal of the AGC controller  $\Delta P_{ref}$  are calculated according to (1) and (2). The output control signal of AGC  $\Delta P_{ref,i}$  ( $i = \overline{1, n}$ , where  $n$  is the number of regulating power plants) is transmitted to the  $i$ -regulating power plant.

At the  $i$ -th power plant control level, the signal  $P_{PCi}$  formed by the power plant PI-controller is calculated as:

$$CE_i = K_{fi} \Delta f + \Delta P_{refi} - \sum_{j=1}^m \Delta P_{ij}$$

$$P_{PCi} = K_{P,i}^{PC} CE_i + K_{I,i}^{PC} \int_{t_1}^{t_2} CE_i dt \quad (4)$$

where  $K_{P,i}^{PC}$  is the proportional gain of the  $i$ -th power plant PI-controller;  $K_{I,i}^{PC}$  is the integral gain of the  $i$ -th power plant PI controller;  $K_{fi}$  is the coefficient of frequency correction at the  $i$ -th power plant;  $\Delta P_{ij}$  is the difference between the actual power and the setpoint power of the  $j$ -th generating unit ( $j = \overline{1, m}$ , where  $m$  is the number of generating units) of the  $i$ -th power plant participating in the secondary frequency control.

The distribution of the control signal  $P_{PCi}$  at the  $i$ -power plant control level is performed in accordance with the participation factors  $\beta_{ij}$  of the generating units in the secondary frequency control (see Fig. 6):

$$\Delta P_{ij} = \beta_{ij} P_{PCi} \quad (5)$$

where  $\Delta P_{ij}$  is the control signal from the  $i$ -th power plant controller. This signal is distributed in such a way that:

$$P_{PCi} = \sum_{j=1}^m \Delta P_{ij} \quad i = 1, 2, \dots, n \quad (6)$$

and

$$\Delta P_{ref} = \sum_{i=1}^n \Delta P_{refi} = \sum_{i=1}^n \sum_{j=1}^m \Delta P_{ij} \quad (7)$$

The calculated control signal  $\Delta P_{ij}$  from the power controller is transmitted to the turbine governor of the generating unit (*aggregate control level*) using the speed changer motor (see Fig. 6). Further, according to the reference control signal  $\Delta P_{ij}$ , the turbine governor

changes the turbine power. Thus, changing the power of the generating units restores the normal frequency and scheduled net interchange power.

The future power system will require an active participation of the HVDC grids to support the AGC function of frequency control. The classical approach is applied to a hybrid AC/DC system where a HVDC link is embedded in a traditional AC system. The structure of the proposed controller enabling the participation of the HVDC link in the AGC support is presented in Fig. 7. There are four control levels of the active power and frequency control [7]. The upper system control level is presented by the AGC of the power system. The input signals are the system frequency measurement  $f_{meas}$  in the power system, the scheduled power on the interface  $P_{tie,ref}$  and line interchanges (AC lines:  $P_{flow,k}$ , and DC line:  $P_{DC}$ ).

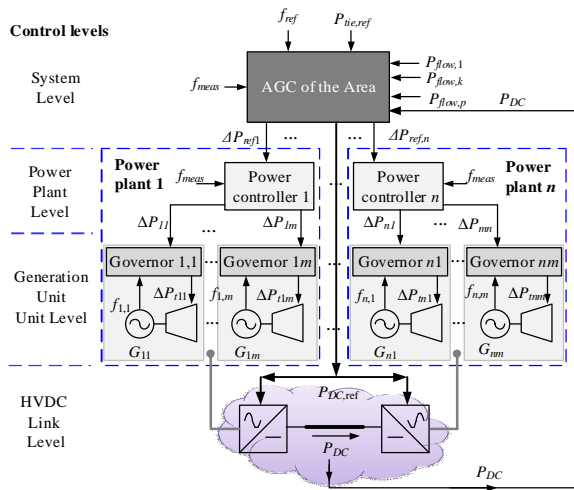

Fig. 7. The structure of a hybrid AC/DC interconnected power system considering the proposed AGC controller.

Based on the tie-line interchanges, the net interchange power ( $P_{tie}$ ) is calculated as:

$$P_{tie} = \sum_{k=1}^p P_{flow,k} + P_{DC} \quad (8)$$

In the AGC of the power system, the system frequency deviation ( $\Delta f$ ) and deviations in the net interchange power ( $\Delta P_{ref}$ ) are calculated. Also, on basis of these values the ACE is calculated. In this paper, the proposed AGC includes a control system to provide signals to the embedded HVDC links in order to provide a frequency sensitive response and control power interchange. The control is designed to make use of the fast response and lower losses of the HVDC system and alleviate the AC transmission system in the interface between the ISPs. A proportional controller is used to define the change in the HVDC based on the AGC:

$$P_{DC,ref} = P_{DC,ref}^0 + g_{HVDC} ACE \quad (9)$$

subject to:

$$P_{DC}^{min} \leq P_{DC,ref} \leq P_{DC}^{max} \quad (10)$$

where  $P_{DC,ref}^0$  is the pre-disturbance power flow on the HVDC link;  $P_{DC}^{max}$ ,  $P_{DC}^{min}$  are power limit of the converter station;  $g_{HVDC}$  is a HVDC participation factor in the secondary control.

It should be noted that in Ukraine, the activities are held to provide the synchronous operation of the IPS with ENTSO-E. One of the cases of the export power flow control is the DC link application. The electricity exporters in Ukraine are also interested in the construction of modern DC links as it provides the flexible control of IPS operation. In particular, including a DC link in the “Burshtyn island” interface in most cases will improve the implementation of a reliable schedule to ENTSO-E and will increase the reserve capacity at Burshtyn thermal power plant.

Using the above-mentioned, the frequency stability of the IPS of Ukraine has been studied considering the DC link connecting Khmelnytska nuclear power plant and Rzeszow substation. In order to simulate long-term dynamics, the detailed model has been developed including the automatic power controller of “Burshtyn island”, AGCs of the IPS of Ukraine and unified power system of Russia, DC link control system and ENTSO-E border area models (750-220 kV network models of Poland, Slovakia, Hungary and Romania). The frequency control simulation is performed in the event of the disconnection of a generating unit at Burshtyn thermal power plant. In Fig. 8, the power flows at the interfaces between the IPS of Ukraine and ENTSO-E are depicted.

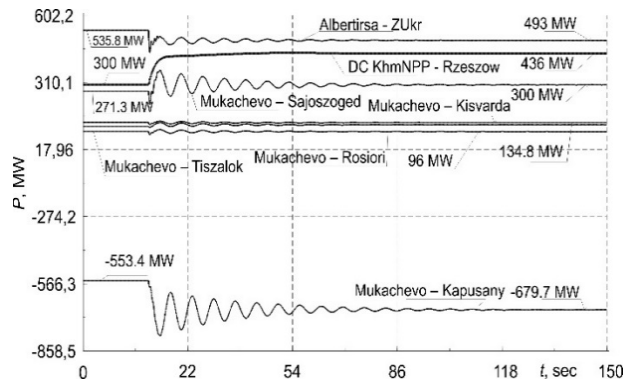

Fig. 8. Power flows between the IPS of Ukraine and ENTSO-E.

Other simulation results, as well as the frequency control structure in the IPS of Ukraine are shown in



detail in [8]. The analysis of power system operation has shown that the modern DC link application enables to provide flexible control of the export power flows in AC/DC hybrid power systems to control the reserve capacity of Burshtyn TPP. Due to the active power flexible regulation by the modern DC link, it becomes possible to use the secondary reserves controlled by the national AGC for “Burshtyn Island”.

### 5. Conclusion

The role of the small-signal stability theory for power systems studies is demonstrated by the practical study case for the ongoing project on the Feasibility Study on Synchronous Interconnection of Ukrainian and Moldovan Power Systems to ENTSO-E. The dynamic models validation example has used the procedures, which are based on both the small-signal stability analysis and the time domain simulation.

It shows a traditional application of the small-signal stability theory for the identification and analysis of poorly-damped power oscillations in modern power systems.

The frequency stability in the event of parallel operation of the IPS of Ukraine and ENTSO-E has also been studied. It is determined that the DC link application considerably enhances the flexibility of export power flows control and consequently allows the frequency regulation to be improved that is one of the requirements of connecting the IPS of Ukraine to ENTSO-E.

### References

- [1] O. Butkevych, “Problem-oriented monitoring of Ukrainian operation condition”, *Tekhnichna Elektrodynamika*, no. 5, pp. 39–52, Kyiv, Ukraine: Institute of Electrodynamics of Ukraine, 2007.
- [2] V. Pavlovskiy, L. Lukianenko, O. Lenga, V. Lambillon, and L. Rese, “Analysis of electromechanical oscillation in the IPS of Ukraine using Eurostag and DigSILENT PowerFactory software tools”, *Tekhnichna Elektrodynamika*, no. 5, pp. 42–52, Kyiv, Ukraine: Institute of Electrodynamics of Ukraine, 2015.
- [3] G. H. Golub and C. F. Van Loan, “Matrix Computations”, *The John Hopkins University Press*, 4<sup>th</sup> Edition, 2013.
- [4] Z. Jiebei, C. D. Booth, G. P. Adam, and A. J. Roscoe, “Inertia emulation control of VSC-HVDC transmission system,” in *Proc. International Conference on Advanced Power System Automation and Protection (APAP)*, pp. 1–6, 2011.
- [5] G. Fujita, G. Shirai, and R. Yokoyama, “Automatic generation control for DC-link power system,” in *Transmission and Distribution Conference and Exhibition 2002: Asia Pacific. IEEE/PES*, vol. 3, pp. 1584–1588, 2002.
- [6] V. Pavlovsky and A. Steliuk, “Modelling of automatic generation control in power systems.” In F. Gonzalez-Longatt and J. L. Rueda, *Power Factory Applications for Power System Analysis*, pp. 157–175, Springer, 2015.
- [7] F. Gonzalez-Longatt, A. Steliuk, and V. H. Hinojosa, “Flexible Automatic Generation Control System for Embedded HVDC Links,” in *Proc. IEEE PowerTech conference*, Eindhoven, 2015.
- [8] O. Kyrylenko, V. Pavlovsky, and A. Steliuk, “Flexible control of the export power flows by using DC link”, *Tekhnichna Elektrodynamika*, vol. 2, pp. 64–70, Kyiv, Ukraine: Institute of Electrodynamics of Ukraine, 2015.

### ПРОБЛЕМИ СТІЙКОСТІ У СУЧАСНИХ ЕНЕРГЕТИЧНИХ СИСТЕМАХ

Олександр Кириленко, Всеволод Павловський,  
Лук'ян Лук'яненко, Антон Стелюк, Олег Ленґа

У статті розглянуто важливі питання стійкості енергосистем. Представлено елементи аналізу статичної стійкості та приклади їх застосування для верифікації моделей з використанням положень динамічної стійкості. Розглянутий приклад верифікації динамічних їх моделей використовує підходи, що базуються на елементах статичної та динамічної стійкості.

В поточний час в Україні здійснюються заходи, направлені на забезпечення синхронної роботи національної об'єднаної енергосистеми (ОЕС) з енергосистемами європейських країн ENTSO-E. Це потребує розв'язання низки задач, зокрема забезпечення стійкості за частотою та керування експортними перетоками для гнучкого керування режимами ОЕС. Так, залучення вставки постійного струму (ВПС) в міждержавному перетині “Бурштинського острова” у більшості випадків забезпечить виконання графіка експортних перетоків в ENTSO-E та збільшить резерви активної потужності на Бурштинській тепловій електростанції (ТЕС).

Враховуючи зазначене, в роботі досліджено стійкість за частотою в ОЕС України з урахуванням ВПС, що з'єднує Хмельницьку атомну електростанцію та підстанцію “Жешув”. Для моделювання довготривалих перехідних процесів розроблено комплексну модель ОЕС України, в якій враховані автоматичний регулятор потужності “Бурштинського острова”, системи автоматичного регулювання частоти та потужності ОЕС України та Єдиної енергетичної системи Росії, систему керування ВПС та моделі прикордонних районів ENTSO-E. Моделювання процесів регулювання частоти виконано для випадку відключення енергоблоку на Бурштинській ТЕС.

### 32 Oleksandr Kyrylenko, Vsevolod Pavlovskiy, Lukian Lukianenko, Anton Steliuk, Oleg Lenga

Аналіз отриманих результатів досліджень показав, що сучасні ВПС забезпечують гнучке регулювання експортними перетоками в гібридних мережах змінного/постійного струму для регулювання резервів потужності Бурштинської ТЕС. Гнучке регулювання активної потужності засобами ВПС відкриває широкі можливості з керування режимами “Бурштинського острова” вітчизняною системою автоматичного регулювання частоти та потужності.



**Oleksandr Kyrylenko** – graduated from Kyiv Polytechnic Institute, Ukraine (1973). From 1975 to present he has been working at the Institute of Electrodynamics of National Academy of Sciences of Ukraine (2007 – Director of the Institute of Electrodynamics of NAS of Ukraine). In 2006 he was elected as Academician of NAS of Ukraine. Main direction of scientific activity - the development of basic theory and development of scientific principles and methods of creation of the integrated informatively-managed systems of electric networks.



**Vsevolod Pavlovskiy** – obtained his M.Sc. in 1992 and his Ph.D, Dc.Sc degrees in 1998 and 2010, respectively. He is currently Senior Researcher at the Institute of Electrodynamics of National Academy of Sciences of Ukraine and concurrently he works as principal engineer at DMCC Ltd. He is IEEE Member. His research interests include power systems simulation, stability analysis and FACTS applications.



**Lukian Lukianenko** – Ph.D. He graduated from “Kyiv Polytechnic Institute” National Technical University of Ukraine (2003). In 2009, he obtained the Ph.D. degree, currently he is senior researcher at the Institute of Electrodynamics of National Academy of Sciences, Ukraine. His research interests include power system stability and renewable energy resources issues.



**Anton Steliuk** – Senior Fellow of the Institute of Electrodynamics of the National Academy of Sciences of Ukraine, PhD (2008). He graduated from “Kyiv Polytechnic Institute” National Technical University of Ukraine (2001). He is an author of more than 50 scientific works. His research interests are related to frequency control in interconnected power systems considering HVDC devices and renewables.



**Oleg Lenga** – graduated from “Kyiv Polytechnic Institute” National Technical University of Ukraine with Master Degree (2012). Currently pursues his postgraduate studies at Institute of Electrodynamics of National Academy of Sciences of Ukraine. The main scientific interests are concerned with mathematical modeling of transients in power systems and impact of renewables on power system stability.