

A MEASURING TRANSDUCER IN THE SYSTEM OF TECHNICAL DIAGNOSIS OF OVERHEAD LINES ICING IN ELECTRICAL DISTRIBUTION NETWORKS

Oleksandr Kozlovskiy¹, Dmytro Trushakov¹, Serhiy Rendzinyak²

¹ Kirovohrad National Technical University, Kirovohrad, Ukraine;

² Lviv Polytechnic National University, Lviv, Ukraine;

kozlovskyoa@gmail.com, dmitriy-kntu@yandex.ru, emd@polynet.lviv.ua

© Kozlovskiy O., Trushakov D., Rendzinyak S., 2015

Abstract: The existing diagnosis systems of icing on wires of overhead power lines use imperfect diagnosis algorithms and icing sensors. In the paper, the schematic diagram of a measuring icing transducer and structure of its sensor based on uninsulated wires of overhead power lines of A and AC types have been substantiated. The sensor consists of a main electrode in the form of an isolated aluminum strand twisted around the central one and a secondary electrode in the form of an adjacent strand. The resistance between the electrodes is measured; if the electrodes are isolated, the resistance between them is close to infinity. If there is ice between the electrodes, its resistance is determined by the resistance of the ice. The threshold values of ohmic resistance of the sensor (AC-50 type wire) have been calculated for two types of ice depositions: rime and hoar frost. To ensure a reduced length of the sensor, additional main electrodes are used. It is shown that, by fixed measurement accuracy, the sensor length depends on the number of additional electrodes, central angles between them being equal. Using the proposed measuring transducer in a diagnosis system allows the formation of rime and hoar frost depositions to be forecasted and registered at an early stage, and thus enables to increase the ice melting effectiveness.

Key words: overhead power line, wires' icing, measuring transducer, sensor of icing.

1. Introduction

Wind and icing are one of the main causes, which lead to technical breakdowns in the work of overhead power lines of electrical distribution networks on the territory of Ukraine. In world practice, there are used passive and active methods of protecting wires and ground wires of overhead power lines from rime and hoarfrost depositions. The active protection methods are considered more economically successful, since the extreme load duration amounts to only 0.03-0.05% of the full line life [1]. Practical implementation of a specific protection method depends on many factors: class of voltage, technical conditions of overhead power lines

and transformer substation equipment, capacity of power transformers, etc. Among the active methods, the most prevalent one is that of ice melting by using electric current whose value exceeds a permissible continuous current and enables to quickly (within an hour from the icing formation) clear overhead power line wires and cables of rime and hoarfrost depositions. To ensure the success of the method, it is necessary to provide well-timed and reliable information on the beginning and development of icing on overhead power line wires.

2. Statement of the problem

One of the main ways of increasing the ice melting effectiveness is introduction of integrated systems of technical diagnosis of wind-icing phenomena on overhead power lines into electric networks of power supply companies. These systems are multifunctional information systems, which are designed on the principle of hierarchy. Their low level is formed by such local diagnostic systems as a system of forecasting of wire icing; a system for early detection of rime and hoar frost appearance and their integral parameters; a system for monitoring of wind-icing load; a data transmission system. The high level consists of a data acquisition system, a diagnostic information processing system, and workstations.

The information systems of icing on overhead power lines in service usually have no forecast system for icing on wires, so the monitoring of a beginning state of rime and hoar frost depositions formation is performed by the system intended to monitor icing and wind load [2]. That is why in most cases, operating personnel receives delayed information about the beginning of icing on overhead power line wires and cables. This is due to imperfect wire icing forecast algorithms, as well as low accuracy of icing monitoring devices, which are currently used. That is why the problem of the development of a measuring transducer for the diagnosis system of icing on overhead power lines in electrical distribution networks is of great current interest.

3. Research goal and results

The process of overhead power line wires icing depends on a large number of meteorological parameters and the parameters of the wire itself [3, 4]. That is why the use of dynamic models based on linear equations in technical diagnosis systems shows significant difficulties during their technical implementation. The most suitable method for a short-term forecast of overhead power line wires icing is considered an instrumental one, which consists in periodic monitoring of a diagnosis parameter, and building of a real-time forecasting model based on the data received. Hence it was developed an instrumental approach to wire icing forecast based on monitoring of change in the duration of artificial cooling

of a part of the wire required for rime and hoar frost depositions formation [5]. For its technical implementation, it is necessary:

- 1) to ensure periodical artificial cooling of a monitored wire part;
- 2) to register rime and hoar frost depositions formation at an early stage.

In accordance with the tasks set, it is possible to consider the following variants of the measuring transducer structure (Fig. 1):

- with direct cooling of an operating overhead power line wire;
- with cooling of an icing sensor designed as the analogue of the overhead power line wire.

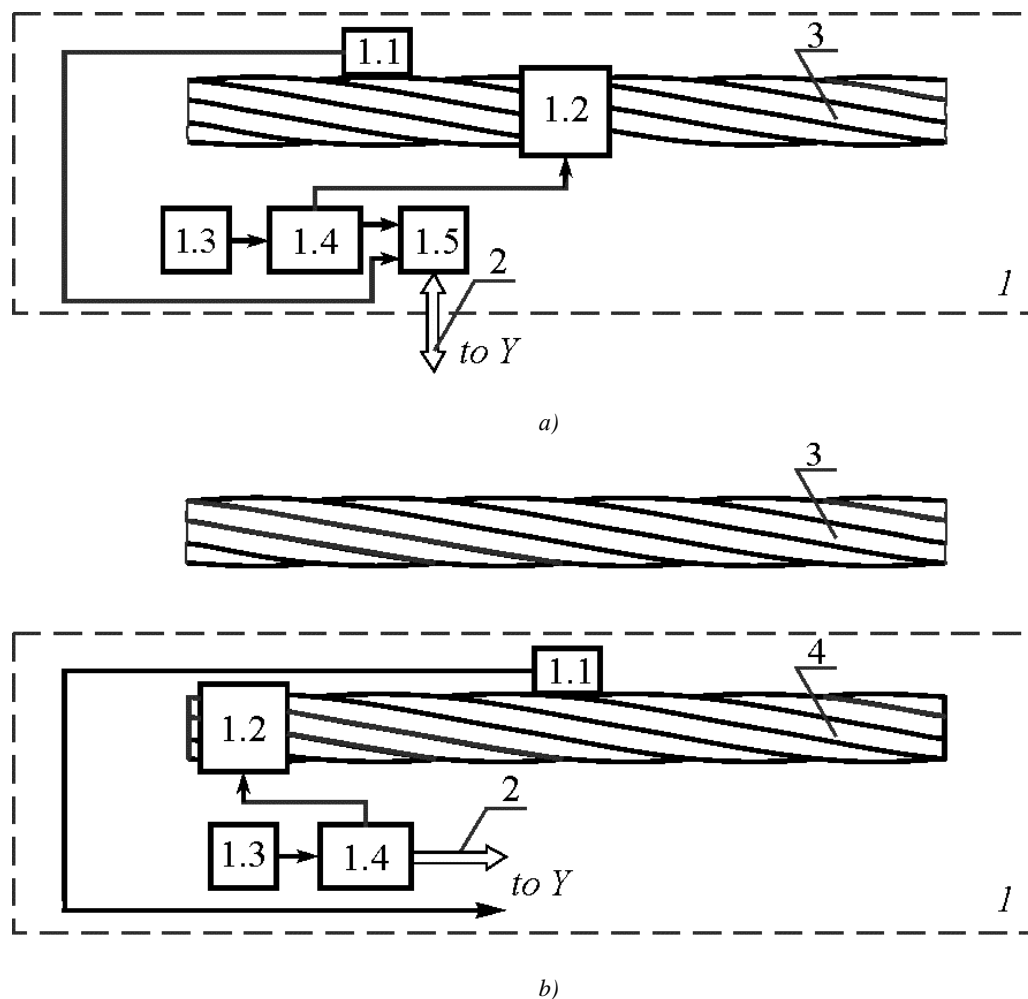

Fig. 1. Variants of implementation of a measuring transducer structure:
a) with direct cooling; b) with cooling of a wire analogue.

In the first case (Fig. 1, a), directly on the overhead power line wire 3 the following units are installed: the measuring unit 1 that consists of icing sensor 1.1, cooler 1.2, power supply unit 1.3, unit of measuring transducers of electric current and voltage 1.4, unit of data coding/decoding 1.5. The measuring unit 1 and a data

processing unit Y mounted on a transmission tower are interconnected via communication channel 2. The direct cooling of an overhead power line wire is connected with a series of considerable difficulties: a great danger while maintaining the measuring unit that carries the wire's potential; complicated structure of power supply;

the need to use a galvanic isolation of the communication channel. That is why the first variant of technical implementation of the forecast algorithm for icing on wires of electrical distribution networks is unacceptable.

While implementing the second variant (Fig. 1, b), Joule heat gain in the wire is neglected. It is justified by the fact that the wires of overhead lines of electrical

distribution networks carry electric currents being much smaller than the designed ones and having no actual influence on the wires' temperature [6].

At present, the only way to ensure the necessary thermal conditions of the measuring transducer at minimum size of the forecasting system for wires' icing is to use semiconductor electronic coolers – thermo-electric modules based on Peltier effect.

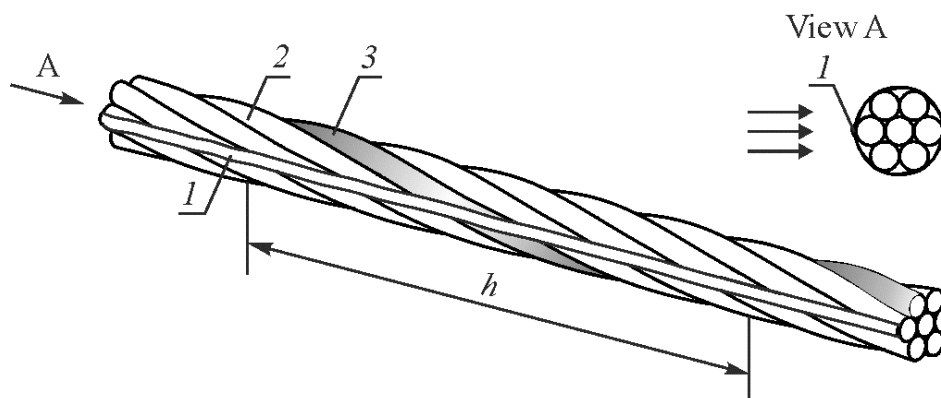

Fig. 2. Sensor structure:
1 – the lane of rime and hoar frost depositions;
2 – main electrode; 3 – secondary electrode.

In measuring transducers for the registration of rime and hoar frost depositions formation, it is better to use the sensor, the physical parameters of which are maximum close to the wire parameters of the monitored overhead power line. Thus, the beginning of the process of forming rime and hoar frost depositions depends on the roughness of body surface, and, furthermore, for cylindrical bodies – on their diameter, because it is a function of the total integral capture coefficient.

The overhead power lines of electrical distribution networks of the Ukrainian power supply companies are made of uninsulated aluminum or steel-cored aluminum wires of A or AC types, respectively [7]. Such a wire is basically a rope made of separate aluminum strands twisted around the central one. The main geometric characteristics are the diameter d_0 of the wire and twisting step multiplicity k . The twisting step h of a wire equals to the product $k \cdot d_0$ (Fig. 2). The twisting step multiplicity of aluminum wires lies within 10÷20 and that of steel-cored aluminum wires does within 10÷28.

Thus, it is advisable that an icing sensor be made of a piece of a wire of the same type as that of the monitored part of the overhead power line, and the wire strands of the upper twisting be used as electrodes (Fig. 2). To ensure bridging of the main and secondary electrodes (Fig. 2, 3) by the lane of rime and hoar frost depositions regardless of the ice deposition direction, the length of the sensor's working part has to be equal to the full twisting step h of the upper wire twisting [8].

The registration of rime and hoar frost depositions is performed by monitoring of the electric resistance between the main (Fig. 2, item 2) and secondary electrodes (Fig. 2, item 3) isolated from each other.

For the purpose of determining the threshold response values of the sensor designed on the basis of AC-50/8 wire, a serial of measurements of its ohmic resistance R_{tr} under conditions given in Table 1 is executed. In the narrow temperature range, the ohmic resistance of rime and hoar frost depositions is effected profoundly by their density [9, 10], that is why the measurement of threshold values R_{tr} is divided into two groups of experiments – for hoar frost and for rime. The experimental studies of the sensor are carried out in a freezer, and the rime/hoar frost depositions with necessary integral parameters are procured artificially from distilled water.

Table 1

Input conditions to estimate threshold values of sensor's resistance R_{tr}

Type of deposition	Number of experiments	Limit surface temperature of the sensor with rime/hoar frost depositions, °C
I - Hoar frost	$n_I = 80$	$-15 \leq t_{SI} \leq -9$
II - Rime	$n_{II} = 82$	$-8 \leq t_{SII} \leq -0.5$

With the hoar frost deposition being on the primary measuring transducer, the results of resistance measurements are focused in the range of 445–550 MΩ. To construct a frequency histogram, the experimental sample is divided into 7 classes by the Sturges rule [11]. Given the number of classes and the scope of sample variation of 550–445=105 MΩ, the class step (the scope of sample variation within one class) is determined at 15 MΩ. According to the data received, a frequency bar chart (i.e. the dependence between the number B_{iI} of random resistance values in i -th class, $i = \overline{1, N_I}$, and the class-average value itself, where N_I is the number of classes for experimental values of hoar frost resistance) is constructed; its shape is close to the shape of normal distribution. Therefore, a hypothesis of normal distribution of the investigated random resistance value is made. Besides, there is plotted a theoretical curve of the normal distribution by the expression below

$$f_I(R_{trI}) = \frac{1}{\bar{S}_I \sqrt{2p}} e^{-\left(\frac{R_{trI} - \bar{R}_{trI}}{2\bar{S}_I}\right)^2} = \frac{1}{22.5\sqrt{2p}} e^{-\left(\frac{R_{trI} - 498.3}{45}\right)^2}, \quad (1)$$

where \bar{S}_I is the corrected sample standard deviation of the sensor's random resistance:

$$\bar{S}_I = \sqrt{\frac{1}{n_I - 1} \sum_{i=1}^{n_I=80} (R_{trI,i} - \bar{R}_{trI})^2} = 22.5 \text{ M}\Omega; \quad (2)$$

\bar{R}_{trI} represents the mean of the random resistance:

$$\bar{R}_{trI} = \left(\sum_{i=1}^{N_I} R_{trI,i} B_{iI} \right) / n_I = 498.3 \text{ M}\Omega, \quad (3)$$

where B_{iI} stands for the observed absolute frequency; its meaning was explained previously.

The verification of the hypothesis on the normal distribution is made using the criteria of compliance χ^2 . For the given level of significance $\alpha = 5\%$ and the number of the degrees of freedom $q_I = 3$, Pearson's cumulative test statistic is $\chi^2_{(q_I=3; \alpha=5)} = 7.815$ [11]. The calculated criterion is less than the tabular value: $\chi^2_I = 3.46 < \chi^2_{(q_I=3; \alpha=5)} = 7.815$, so the hypothesis of normal distribution is fulfilled for the given level of significance of 5%.

The thresholds of R_{trI} are determined by the rule of $3S$, where instead of standard deviation S the corrected sample standard deviation \bar{S}_I is used, then:

– for the confidence level of 0.955:

$$454.3 \text{ M}\Omega \leq R_{trI} \leq 542.3 \text{ M}\Omega$$

– for the confidence level of 0.997:

$$432.3 \text{ M}\Omega \leq R_{trI} \leq 564.2 \text{ M}\Omega.$$

Similar calculations were done for R_{trII} , i.e. for the experimental sample obtained when there is rime on the sensor. The verification of the hypothesis on the normal distribution is made using the criteria of compliance χ^2 . For the given level of significance $\alpha = 5\%$ and the number of the degrees of freedom $q_{II} = 4$, Pearson's cumulative test statistic is $\chi^2_{(q_{II}=4; \alpha=5)} = 9.448$ [11]. The hypothesis of normal distribution is also fulfilled for the given level of significance of 5%:

$$\chi^2_{II} = 4.37 < \chi^2_{(q_{II}=4; \alpha=5)} = 9.448.$$

The thresholds of R_{trII} are as follows:

– for the confidence level of 0.955:

$$16.5 \text{ M}\Omega \leq R_{trII} \leq 21 \text{ M}\Omega;$$

– for the confidence level of 0.997:

$$15.4 \text{ M}\Omega \leq R_{trII} \leq 22 \text{ M}\Omega.$$

If there is a need for a space-saving measuring transducer to be developed at fixed measurement accuracy, the length of the sensor may be reduced by increasing the number of main electrodes providing that all the central angles between them are the same [12]. To determine analytically the minimal length of the sensor, we set down the requirement of bridging of at least one of m isolated electrodes and a secondary electrode by the lane of rime and hoar frost depositions; therefore, we need to solve the following mixed system:

$$\left. \begin{aligned} x &= r \cos\left(t + \frac{2\pi p}{m}\right), \\ y &= r \sin\left(t + \frac{2\pi p}{m}\right), \\ l &= \frac{h}{2\pi} t, \\ y &= 0, \\ x &> 0, \end{aligned} \right\} \quad (4)$$

where x, y are coordinates of the Cartesian frame coinciding with the cross section of the wire; r denotes the radius of the wire circular cylinder; t stands for central angle; p is the number of additional main

electrodes, $p = 0, 1, \dots, m-1$; l represents the length of the working part of the sensor.

Let us solve the system (4):

$$r \sin\left(t + \frac{2\pi p}{m}\right) = 0$$

For $z < h$

$$t + \frac{2\pi p}{m} = 2\pi$$

$$t = 2\pi - \frac{2\pi p}{m}.$$

We obtain the length of the sensor containing m isolated additional electrodes

$$l = \frac{h}{2\pi} t = \frac{h}{2\pi} \left(2\pi - \frac{2\pi p}{m}\right) = h - \frac{ph}{m}. \quad (5)$$

The analysis of wires with cross-sectional areas ranging from 35 to 185 mm² (by aluminum part) has shown that their upper twisting has an even number of wire strands except the wire of AC-150/19 and AC-185/29 types. Thus, according to (5), the possible length of the sensor based on AC-50/8 wire at $h = 240$ mm is of 240 mm, 120 mm or 80 mm for the number of main electrodes $m=1$, $m=2$ or $m=3$, respectively.

4. Conclusion

Given the research results, it is possible to draw the following conclusions.

The existing systems for diagnosis of icing on wires of electrical distribution network overhead lines use imperfect diagnosis algorithms and icing sensors.

The schematic diagram of a measuring icing transducer and structure of its sensor based on uninsulated wires of overhead power lines of A and AC types have been substantiated.

It has been shown that the sensor length, at fixed measurement accuracy, depends on the number of additional electrodes, central angles between them being equal.

5. References

- [1] V. Burhsdorf, "Melting ice in power systems as a means for effective enhancement of reliability of electric networks", in *Proc. 2nd Union Conf. Melting ice on overhead power lines*, pp. 6–10, Ufa, Russia, 1975. (Russian).
- [2] I. Levchenko, A. Alliluyev, A. Lubenets, and F. Dyakov, "Telemetry system of ice loads on overhead power lines 6-35 kV", *Elektricheskiye stantsii*, no. 8, pp. 43–47, 1999. (Russian).
- [3] M. Ter-Mkrtchian, A. Snitkovskiy, and L. Lukiyanova, "Using discriminant analysis to forecast ice", *Trudy gidrometeocentra SSSR*, vol. 90, pp. 3–39, 1971. (Russian).
- [4] I. Kolmogorova, M. Cybidorzhev, and A. Vinarov "Forecasting of formation of ice", *Tekhnika v selskom khoziaystve*, no. 5, pp. 13–15, 1987. (Russian).
- [5] O. Kozlovskiy and A. Orlovych, *Method of forecasting of icing on wires of overhead power lines*, Ukraine Patent № 53235, 2003. (Ukrainian).
- [6] V. Vorotnickiy and O. Turkina, "Estimation of variable losses calculation errors of electrical power HV lines caused by unaccounted meteoconditions", *Elektricheskiye stantsii*, no. 10, pp. 42–49, 2008. (Russian).
- [7] GOST 839 (1980), Uninsulated wires for aerial power lines. Specification. Moscow, Russia. (Russian).
- [8] O. Kozlovskiy, A. Orlovych, and I. Hryshchuk, *Icing indicator for overhead power line wires*, Ukraine Patent № 49394, 2013. (Ukrainian)
- [9] N. Maeno, *The science of ice*. Hokkaido, Japan: Hokkaido University Press, 1981.
- [10] *Handbook of snow: principles, processes, management & use*, Edited by D. Gray and D. Male. Toronto, Canada: Pergamon Press, 1981.
- [11] E. Lvovskiy, *Statistical methods for constructing empirical formulas*. Moscow, Russia: Vysshaya shkola, 1988. (Russian).
- [12] O. Kozlovskiy, "Improving of primary measuring icing detector for overhead power lines". In *Tekhnika in agriculture, industry-machinery, automation*, pp. 290–294, Kirovohrad, Ukraine: Kirovohrad National Technical University, 2015 (Ukrainian).

ВИМІРЮВАЛЬНИЙ ПЕРЕТВОРЮВАЧ СИСТЕМИ ТЕХНІЧНОГО ДІАГНОСТУВАННЯ ОЖЕЛЕДОУТВОРЕННЯ НА ПОВІТРЯНИХ ЛІНІЯХ РОЗПОДІЛЬНИХ ЕЛЕКТРИЧНИХ МЕРЕЖ

Олександр Козловський, Дмитро Трушаков,
Сергій Рендзіняк

Існуючі системи діагностування обледеніння (у вигляді утворення ожеледних та паморозних відкладень на проводах повітряних ліній розподільних електромереж використовують недосконалі алгоритми діагностування та сенсори обледеніння. Обґрунтовано структурну схему вимірювального перетворювача для діагностування явища обледеніння та конструкцію його сенсора на базі неізолюваних

проводів повітряних ліній електропередачі типів А, АС. Конструктивно сенсор являє собою основний електрод у вигляді ізольованої дротини, скрученої навколо центральної, та допоміжний електрод у вигляді сусідньої дротини. Для зменшення довжини сенсора можна збільшити кількість основних електродів. Розраховано порогові значення омичного опору сенсора (провід АС-50) для двох видів ожеледно-паморозевих відкладень: паморози та ожеледі. Показано, що довжина сенсора, за незмінної точності вимірювань, залежить від кількості допоміжних електродів, при рівності центральних кутів між ними. Застосування запропонованого вимірювального перетворювача у складі системи технічного діагностування дає змогу прогнозувати та фіксувати утворення ожеледно-паморозевих відкладень на ранній стадії і таким чином підвищити ефективність проведення плавки ожеледі.



Oleksandr Kozlovskiy – graduated from Kirovohrad State Technical University (major “Electrical power consumption”), Ukraine. He has been working at Kirovohrad National Technical University since 2001 as Assistant Professor at the Department of Automation and Power Engineering. Area of research: systems for diagnosis of icing on overhead power lines of electrical networks.



Dmytro Trushakov – graduated from Kirovohrad Institute of Agriculture Machine Design (major “Automation and Control in Technical Systems”), Ukraine. He defended his Ph. D. dissertation thesis at Kirovohrad National Technical University, Ukraine, in Automation of Technical Processes.

He has been working at Kirovohrad National Technical University since 1997 as Senior Lecturer at the Department of Automation and Power Engineering.



Serhiy Rendzinyak – graduated from Ivan Franko State University, Lviv, Ukraine (major “Radio Physics and Electronics”). He defended his Ph. D. dissertation thesis at Ivan Franko State University, Ukraine, and did his DSc dissertation thesis at Lviv Polytechnic National University in Theoretical Electrical Engineering. He worked at Lviv Polytechnic National University as Associate Professor from

1997 to 2008; since 2008 he holds the position of Professor at the Department of Electrical Engineering, Lviv Polytechnic National University.