

урахуванням потрібної продуктивності процесу, яка визначається відповідним технологічним процесом.

1. Габович М.Д., Плешивец Н.В., Семашко Н.Н. Пучки ионов и атомов для управляемого термоядерного синтеза. М., 1986.
2. Битнер Л.Р., Ведерников В.А., Данилина Т.И., Маняхина Г.В., Шандра З.А. // Изв. ВУЗов. Физика, № 12, 1976. – С.11–15.
3. Крейндель Ю.Е. Плазменные источники электронов. – М., 1977.
4. Баберцяи Р.П., Бадалян Э.С., Егназарян Г.А., Тер-Геворкян Э.И. //ЖТФ, №9, 1998. – С.29–32.
5. Агафонникова Е.В., Шандра З.А. Сверхпроводимость: физика, химия, техника // №1, 1992/ – С. 123–127.
6. Шандра З.А. // Вісник ДУ “Львівська політехніка”, 1999, №382. – С.56–60.

I. Bolshakova<sup>1</sup>, V. Brudnyi<sup>2</sup>, V. Boiko<sup>3</sup>, N. Kolin<sup>3</sup>,  
M. Kumada<sup>4</sup>, C. Leroy<sup>5</sup>, D. Merkurisov<sup>3</sup>

<sup>1</sup>Lviv Polytechnic National University, Lviv, Ukraine,

<sup>2</sup>Siberian Physical Technical Institute, Tomsk, Russia,

<sup>3</sup>Obninsk Branch State Research Center “Karpov Institute of Physical Chemistry”, Obninsk, Russia,

<sup>4</sup>NIRS, Chiba-shi, Japan,

Laboratoire R.-J.A. Leversque University of Montreal, Canada

## THE RADIATION HARDNESS OF MAGNETIC SENSORS AND DEVICES IN EXTREME CONDITIONS OF IRRADIATION WITH HIGH NEUTRON FLUXES

© Bolshakova I., Brudnyi V., Boiko V., Kolin N.,  
Kumada M., Leroy C., Merkurisov D., 2004

**The radiation hard magnetic field sensors are based on indium antimonide semiconductor compound microcrystals. The tests performed have shown the high stability of their characteristics under irradiation with reactor neutrons up to very high fluences of  $10^{16} \div 10^{18}$  n·cm<sup>-2</sup>. The magneto-measuring facility has been built with measurement channels of high accuracy of 0.01%.**

### Introduction

Experiments on the direct measurements of Hall sensors directly during their irradiation have not been performed up to this time. This is related with a series of difficulties in conducting such experiments. First of all, it is necessary to locate the magnet as a magnetic induction source in the neutron reactor channel. Besides, it is necessary to provide the control of the magnet parameters under the reactor neutrons irradiation. And finally, it is necessary to provide the measurement instrumentation which allows the amplification and protection of the measured signals from noises on the distance of several dozens of meters.

The results of investigations of the neutron irradiation influence on the characteristics of indium antimonide semiconductor material for sensors were reported previously [1]. However, all these previous investigations were indirect and were carried out in several stages. First, the measurements of characteristics of the samples were performed in the laboratory environment using hall measuring benches. Then, samples were transferred to the nuclear research center, where they were exposed to the neutron fluence. At the next stage, the samples was held in “quarantine” under radiation monitoring until the induced radioactivity decreased to the radioactive background standard. Only after that the samples under the investigation were returned to the laboratory, where were performed the measurement and analysis of

possible modifications of their characteristics, possibly due by radiation defects produced by neutron exposure. At the same time, the “quarantine” time was dependent on the radiation dose and lasted from one up to several days, and in case of high radiation doses – up to several months. During such a long period, different relaxation processes might occur in the samples, which are called “defects annealing” in radiation physics. For the indium antimonide semiconductor material under investigation used for highly sensitive magnetic field sensors, the annealing of radiation defects may occur even at room temperature because of the small value of the band gap width.

Therefore, the information about the behavior of semiconductor materials and sensors properties directly under irradiation is very important for the creation of radiation hard devices, as well as for the understanding of the radiophysical processes occurring in the material under the influence of high energy neutrons.

### The experiment

The direct investigation of the influence of fast neutrons onto the semiconductor sensors has been carried out in the channel of the Fast Pulsed Reactor IBR-2 at the Joint Institute of Nuclear Research in Dubna (Russia) and in LVR-15 reactor in Nuclear Research Institute at Řez (Czech Republic).

The experiment in IBR-2 reactor has been performed in three sessions of a total duration of 90 days, the temperature of the experiment was 17°C. The investigated samples were placed in the gap between the poles of a permanent magnet and were placed together with the magnet into the nuclear reactor channel. They were connected by a special cable to the measuring facility, being located at 30 meter distance from the reactor channel. By this cable, the feed current for the samples was supplied and the signals of hall voltage were transmitted from the samples to the measuring facility.

During the first session of reactor operation, the samples under investigation were irradiated up to a fluence of  $F_1=7,4 \cdot 10^{15} \text{ n cm}^{-2}$  at a flux intensity of  $j=6,86 \cdot 10^9 \text{ n} \cdot \text{cm}^{-2} \cdot \text{s}^{-1}$ , until the end of session II – up to the fluence of  $F_2=1,0 \cdot 10^{16} \text{ n} \cdot \text{cm}^{-2}$  at  $j=1,07 \cdot 10^{10} \text{ n} \cdot \text{cm}^{-2} \cdot \text{s}^{-1}$  and until the end of session III – up to the fluence of  $F_3=3,1 \cdot 10^{16} \text{ n} \cdot \text{cm}^{-2}$  at  $j=8,46 \cdot 10^9 \text{ n} \cdot \text{cm}^{-2} \cdot \text{s}^{-1}$ . The average reactor neutron energy was equal to  $E=1.5 \text{ MeV}$ , the portion of thermal and intermediate neutrons present in the total neutron flux was equal to 20% and 25% of the total neutron flux, respectively.

Such experiment with the location of magnetic field source and Hall samples in the neutron reactor channel was performed for the first time. It became possible, thanks to the specially produced magnetomeasuring MMS1 facility, to extract, amplify and protect from noises the weak signals generated by hall voltage magnetic field in miniature samples and to transfer them over a long distance.

In a MMS1 magnetomeasuring facility, the special noise resistant methods for signal processing, which are based on the synchronous detection [2], are used. The developed facility is multifunctional. It provides a measurement accuracy of 0,01% on those parameters changes that occur in the investigated samples while exposed to neutrons. Besides, it allows the control of the temperature in the zone, where the samples are located, with an accuracy of 0,1°C. It also allows periodically the control of possible changes of induction of the permanent magnet, being placed in the neutron reactor channel under the influence of the fast neutrons flux. For this purpose, the testing measurement method is used, with which the Hall sensor, placed between the permanent magnet poles, measures by turns the magnetic fields of permanent magnet and actuating coil, which is formed on the cylindrical poles of the permanent magnet and is fed by alternating current. As a result of the appropriate processing of the measurements, the drift of pole of the permanent magnet is calculated, which can take place during the fast neutrons exposure onto the permanent magnet material. In this case, within the limits of experiment accuracy, the permanent magnet pole, made of  $\text{SmCo}_5$ , did not practically change during the experiment up to a maximal irradiation dose of  $3.1 \cdot 10^{16} \text{ n} \cdot \text{cm}^{-2}$ .

The samples under investigation, the permanent magnet and the measuring device were located in three zones (fig.1).

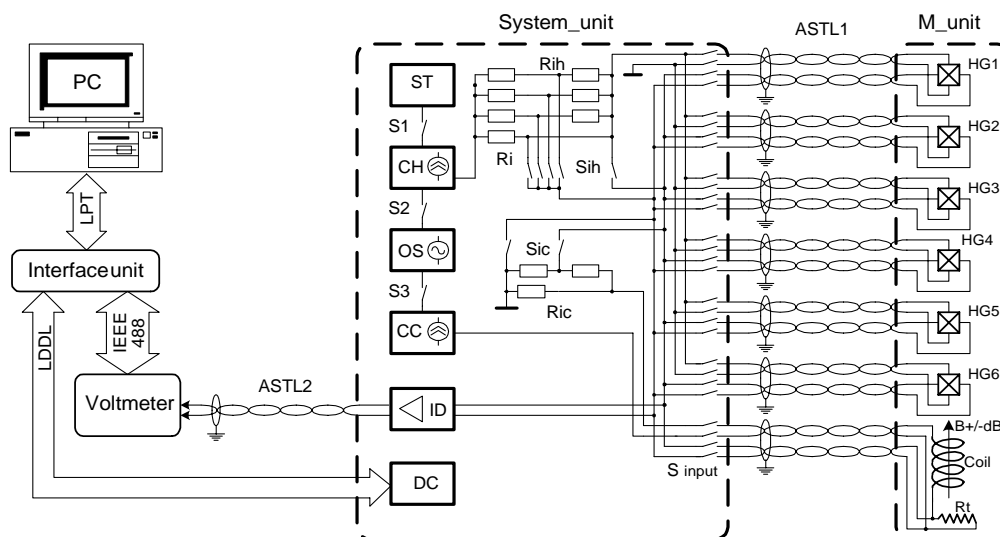

Fig. 1. Structure chart of MMS1 system: HG – the samples under investigation, ST – a stabilizer, CH and CC – a current source, OS – a former of reference voltage, ID – input amplifier, DC or CD – command decoder, ASTL – signals' transmission line

In the first zone- in the reactor zone- was placed the permanent magnet unit together with investigated M\_unit samples. In the second zone – in the technical room at the 10-meter distance from the reactor channel- was installed the basic unit of the measuring system\_unit facility. In the third zone –in the room for personnel work at the 30-meter distance from the reactor channel- were placed the Keithley? – 2000 voltmeter, an interface unit and a personal computer.

The experiment in the LVR-15 reactor lasted for 20 days. The fast neutron flux intensity, with an average neutron energy of more than 1 MeV, was  $1.4 \cdot 10^{11} \text{ n} \cdot \text{cm}^{-2} \cdot \text{s}^{-1}$ . The irradiation temperature was  $90^\circ\text{C}$ .

An automatic system for periodical sensor calibration during the whole irradiation cycle was built for the study of sensor samples in this reactor. Eight sensors at the measurement head together with measurement head were placed in vertical channel next to the reactor core [3].

All eight sensors were irradiated with fast neutrons up to a fluence of  $2,5 \cdot 10^{17} \text{ cm}^{-2}$ . The total fluence accumulated by each sensors was different due to the differences of sensor position inside the reactor channel. This difference was within the range  $2,5 \cdot 10^{17}$  to  $1,3 \cdot 10^{18}$ .

## Results

### The experiment at the IBR-2 reactor.

Among 6 samples under investigation, three, labelled 1, 2, and 3, were manufactured from discrete monocrystalline whiskers with a initial carrier concentration of  $n_1=8,6 \cdot 10^{16}$ ,  $n_2=6,4 \cdot 10^{17}$ , and  $n_3=9,7 \cdot 10^{17}$ , respectively. The other three, labelled 4, 5, and 6 belonged to film InSb samples with a initial carrier concentration of  $n_4=3,0 \cdot 10^{18}$ ,  $n_5=7,5 \cdot 10^{17}$ , and  $n_6=3,4 \cdot 10^{17}$ , respectively. The level of electron concentration in each sample was regulated by the introduction of an amount of major impurity Sn. The other impurity complex added, i.e., Al and Cr, played the role of getters for background impurities and radiation defects drains.

The results of measurement related to sensor sensitivity change under irradiation are shown in fig. 2, where the experimental points representing numerous measurements (about three hundred thousands) are merged in solid lines on a given scale.

From the analysis of the measurement results shown in Fig. 2, it follows that sensor 2 is the most stable over the whole fluence interval. The initial electron concentration in this sample is  $n_2=6,4 \cdot 10^{17} \text{ cm}^{-3}$ . Up to the highest neutron fluence of  $3,1 \cdot 10^{16} \text{ n cm}^{-2}$ , the change in its sensitivity did not exceed 1% relatively to the initial value, and at the fluence of  $1 \cdot 10^{15} \text{ n cm}^{-2}$ , it amounted to only 0,05%.

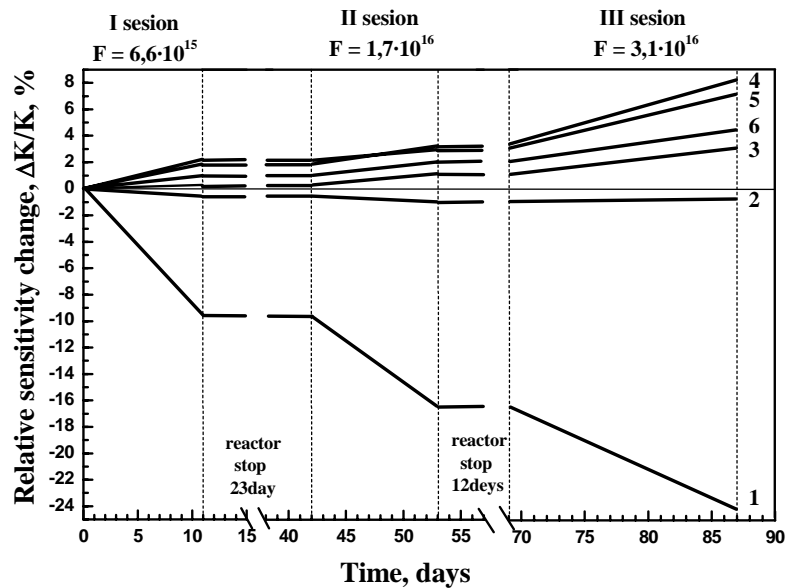

Fig. 2. The relative sensitivity change of sensors based on whiskers (curves 1,2,3) and based on films (curves 4,5,6) of InSb under the neutron irradiation (direct measurements) in the IBR-2 reactor channel

The stability of the film sensors with an electron concentration being close to the optimal one for whiskers, is considerably worse: at the same concentration at a fluence of  $3,1 \cdot 10^{16} \text{ n}\cdot\text{cm}^{-2}$ , their sensitivity has changed by approximately 7%. It may possibly be caused by the structure defects, as thin films following the way of development present more defects than whiskers monocrystals, obtained during a free crystallisation from gas phase.

During reactor stops in between irradiation sessions, the facility continued to perform measurements during the next several days in order to find out if sensors characteristics were affected by relaxation after the irradiation.

The results of the measurements showed, that the characteristics of sensors based on whiskers do not relax at all after the reactor stop (fig.3).

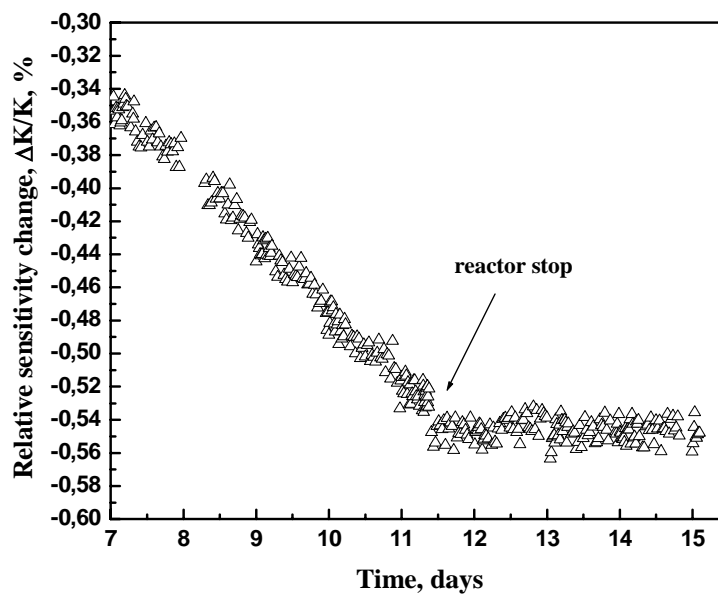

Fig. 3. The dependence as a function of time of relative sensitivity change of crystalline sensor (whisker 2) at the end of the first irradiation session and during the first reactor stop

Some relaxation could be observed in film samples after the reactor stop (fig. 4).

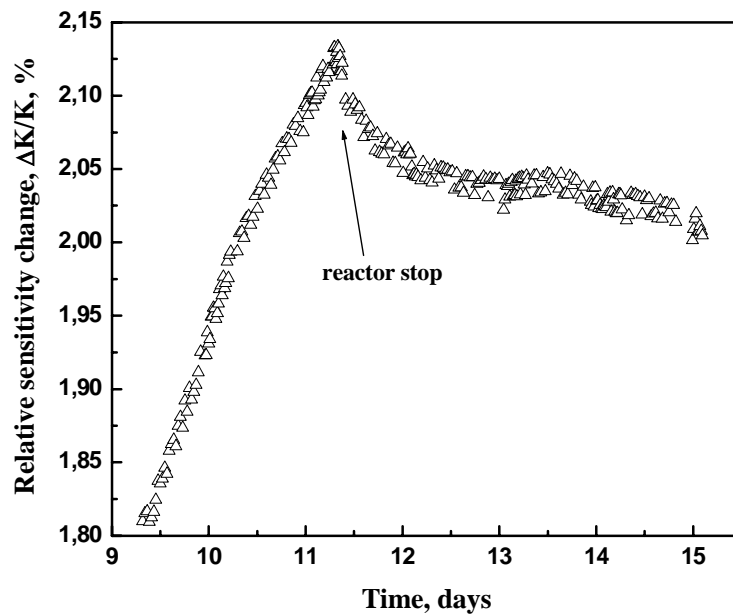

Fig. 4. The dependence as a function of time of relative sensitivity change of film sensor (sample 5) at the end of the first irradiation session and during the first reactor stop

In fig. 5, is shown the fragment of measurement of a sensor on the other scale. One can see that the accuracy of the facility measuring channels is very high and amounts to  $\pm 0,01\%$ . Such high measurement accuracy allowed us to state even short-term power discharges of the reactor, one of which can be seen in this figure.

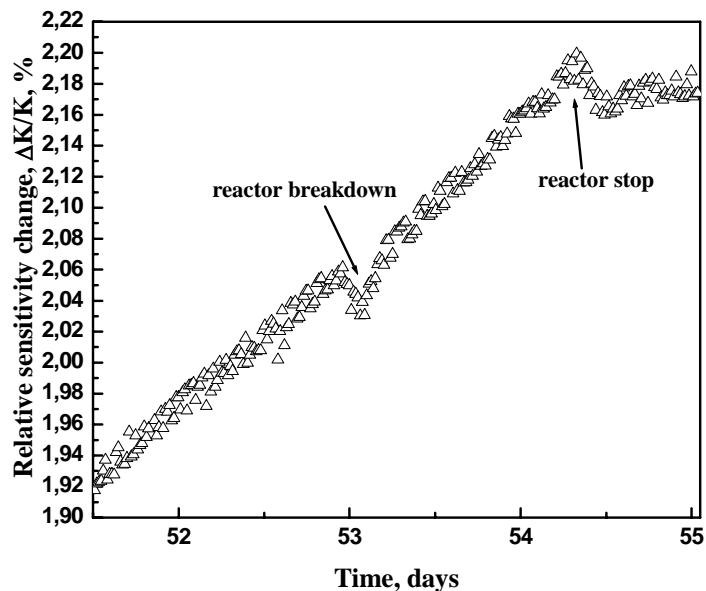

Fig. 5. The dependence as a function of time of relative sensitivity change of film sensor (sample #6) sensitivity during the second irradiation session and reactor breakdown

#### The experiment in LVR-15 reactor.

In this experiment 8 sensors have been studied. Four of them were made by the US companies F.W. Bell and Lake Shore Cryotronics, and the rest were manufactured by Magnetic Sensor Laboratory (MSL) of the Lviv Polytechnic National University (table 1).

Table 1

**The set of Hall sensors used for the tests in LVR-15 reactor**

Type	Manufacturer	Material	Sensitivity, mV/T	Max. control current, mA	Max. operation temperature, °C
MSL-1	MSL, Lviv, Ukraine	InSb	15	40	100
MSL-2	MSL, Lviv, Ukraine	InSb	6	40	100
MSL-3	MSL, Lviv, Ukraine	InSb	10	50	100
MSL-4	MSL, Lviv, Ukraine	InSb	10	75	100
HGT-3010	Lakeshore, USA	InAs bulk, highly doped	10	100	100
HGT-3030	Lakeshore, USA	InAs, bulk low doped	100	100	100
HS-100	F.W. Bell, USA	InAs thin film	240	30	185
GH-800	F.W. Bell, USA	GaAs bulk	1000	5	175

The results of the irradiated sensors sensitivity change are shown in table 2. The best results were obtained for the set of sensors, manufactured at MSL, Lviv. The sensitivity of the best MSL-2 sensor from this set remain stable (change by less than 10%) during the whole irradiation campaign up to the fluence of  $3 \cdot 10^{17}$  n cm<sup>-2</sup>. The other two sensors of Magnetic Sensor Laboratory – MSL-3 and MSL-4 were irradiated up to the maximal fluences ( $1,1 \cdot 10^{18}$  n cm<sup>-2</sup> and  $1,3 \cdot 10^{18}$  n cm<sup>-2</sup>, respectively). After irradiation they remain quite fit for operation. Such changes in the sensor sensitivity can be handled by in-situ recalibration techniques, if properly applied.

Table 2

**The results of sensors tests in LVR-15 reactor**

Type of Hall sensor	Total fast neutron (E>1MeV) accumulated fluence [n/cm-2]	Remaining sensitivity after irradiation by fast neutron fluence of $2.5 \times 10^{17}$ cm <sup>-2</sup> (in % of original values).	Remaining sensitivity after irradiation by the total fast neutron fluence (in % of original values).
MSL-1	$2.5 \times 10^{17}$	<b>77 %</b>	77 %
MSL-2	$3.0 \times 10^{17}$	<b>94 %</b>	93 %
MSL-3	$1.1 \times 10^{18}$	<b>82 %</b>	62 %
MSL-4	$1.3 \times 10^{18}$	<b>85 %</b>	70 %
HGT-3010	$4.8 \times 10^{17}$	<b>58 %</b>	44 %
HGT-3030	$8.4 \times 10^{17}$	<b>13.8 %</b>	5.6 %
HS-100	$3.6 \times 10^{17}$	<b>30.2 %</b>	25 %
GH-800	$9.8 \times 10^{17}$	<b>destroyed</b>	destroyed

### Conclusion

The direct measurement of semiconductor magnetic sensor characteristics was performed for the first time during fast neutron exposure in reactor channel.

It was shown that the semiconductor sensor characteristics can be sufficiently stable up to high fluences  $10^{15} \div 10^{18} \text{ n}\cdot\text{cm}^{-2}$ . This makes possible their application for the magnetic field measurement in accelerators and thermonuclear fusion facilities.

For magnetic field monitoring, the special magneto-measuring system with measuring channels accuracy of 0.01%, possessing self-control and self-correction functions was created.

1. Bolshakova I. *Sensors and Actuators: A Phys.*, 106, p. 344-347, 2003.
2. Bolshakova I. et al., *IEEE Trans. Appl. Superc.*, 12 (1), p. 1655-1658, 2002.
3. Duran et al.: *Irradiation effects on candidate Hall probes, final report on EFDA Technology Task TW3-TPDC-IRRCER Deliverable 9, June 2004.*

**O. Hotra<sup>1</sup>, E. Lychkovskij<sup>1</sup>, B. Stadnyk<sup>2</sup>**

<sup>1</sup>Department of Biophysics, Lviv National Medical University,

<sup>2</sup>Department of Information Measuring Technique,  
Lviv Polytechnic National University, Lviv, Ukraine

## **THERMOSENSITIVE INTEGRATED CIRCUITS WITH RELATIVE TEMPERATURE SCALE**

© Hotra O., Lychkovskij E., Stadnyk B., 2004

**On the basis of the received results of investigations new thermosensitive IC based on negative differential conductivity are created. These IC provide the possibility of temperature control in the wide temperature range of  $-50\dots+120^{\circ}\text{C}$ .**

Thermometry is one of directions of development of devices and methods of measuring of thermal quantities. Measuring of temperature is connected with many directions of man's activity. The requirements to the methods of temperature measuring and temperature measuring devices raise all the time. Measuring devices, which provide higher accuracy, high speed, protection from the external influence are needed. Medicine, biology need creation of temperature measuring devices for a narrow range from a few Celsius degrees in a wide range ( $-50\dots+150^{\circ}\text{C}$ ), with high speed, miniature sizes, with possibility of their introduction into the body or in a biological object.

The search of new methods and devices of temperature control is continued all the time. Lately temperature sensors, in which the functions of primary and secondary transducers are in single structural performance, were wider researched and developed. In these sensors (intelligent sensors) miniaturization and self-correction considering the changes of external factors, including changes of parameters of supply, are carried out. One of directions of realization of such sensors are single chip thermosensitive integrated circuits, which eliminate direct dependence of transduction function on the parameters of elements and allow to make devices without their individual calibrating. Range of temperature measuring of these IC is equal  $(-50\dots+125)^{\circ}\text{C}$ , error of transduction function is equal  $(1\dots3)\%$ . Interchangeability, simplicity of switching, small sizes, low cost are advantages of these IC. Such thermosensor devices are widely used in a domestic technique, biomedical electronics, apparatus of the ecological monitoring. The problems of their development, increase of accuracy, providing the given temperature range of measuring, principles of their structure are studying.

Analyzing modern development state one can show that research and elaboration of temperature sensors on the basis of integrated electronics is an actual task, the solving of which is needed for acceleration of scientific and technical progress in all directions of science, technique, medicine, ecology, etc.

Thermosensitive IC were one of the directions of our investigations. Nowadays there are thermosensitive IC with absolute temperature scale, output signal of which is proportional to the absolute temperature. But in some cases the signal that have information about an absolute temperature (for example, 300K, that corresponds to  $27^{\circ}\text{C}$ ) is not enough informational for measuring of  $0,1^{\circ}\text{C}$  or  $0,01^{\circ}\text{C}$ .