

Drawing capitals of classical orders at the early stages of architectural activity

Taras Baran¹, Oksana Bilinska²

1 Department of Restoration and Reconstruction of Architectural Complexes, Lviv Polytechnic National University, UKRAINE, Lviv, S. Bandery Street 12, E-mail: beirieman@gmail.com

2 Department of Design and Architecture Basics, Lviv Polytechnic National University, UKRAINE, Lviv, S. Bandery Street 12, E-mail: oksanabilinska@gmail.com

The research outlines the importance and value of drawing architectural details (capitals of classical orders) during the process of studying architecture. It describes the successive stages of drawing capitals, provides graphical schemes of their construction and emphasizes the key features of modeling capitals of Tuscan, Doric, Ionic and Corinthian orders.

Keywords - drawing, perspective, architectural detail, architectural order, Tuscan capital, Doric capital, Ionic capital, Corinthian capital, decoration.

I. Introduction

The classic way of studying and researching the best samples of the Ukrainian architecture by drawing architectural details and small forms was established at the Department of History of Architecture at Lviv Polytechnic by Yulian Zakharevych, back in 1880-85. This tradition of academic drawing continues up to this day at the Department of Design and Architecture Basics. Drawing both separate capitals and their involvement in still nature settings helps students to get acquainted with classical architectural forms during the I - III years and is essentially important at the initial stage of students' learning. In such a way students learn classical fragments of buildings, architectural orders, outstanding works of international and domestic architecture. The study of monuments occurs as well in the process of drawing expressive nature sketches of historic buildings by using various techniques and means of architectural graphics, subsequently leading to high-quality sketches, restoration and tonnage drawings etc.

Acquiring the skills of drawing architectural details of classical orders is very important at the initial stage of training architects, as these skills are organically and systematically related to such majors as architectural design, architectural graphics, architectural composition and provide the formation of three-dimensional thinking, artistic taste and observation, learning by drawing and memorising classical forms of architecture. Drawing promotes creativity skills of architects in their further education and professional activity.

II. Capital - the Optimal Model for Drawing

The main objectives of drawing capitals of architectural orders are to transfer onto the paper surface three-dimensional shapes of plaster models of capitals using the

method of linear perspective and visual perception, by using pencil graphics; to analyse volume patterns by partitioning it, using auxiliary lines as simple, clear volume connectors; to ensure the unity of the parts and the whole, using light and shadow tones to identify local character and form of nature, its design and proportions [1-11].

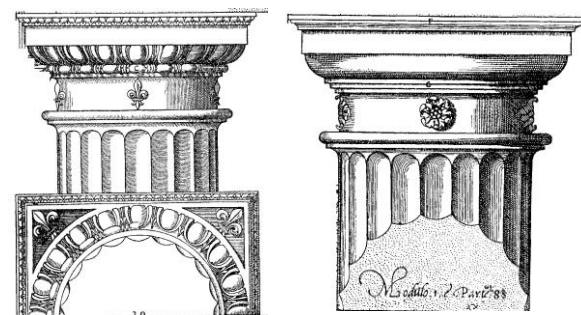

Fig. 1. Doric order by Vignola

The variety of capitals makes these parts of classical orders the best educational model for drawing. The capital is the top of a column, which shows how the load is transferred from the beam to the column. This architectural element of an order is the universal language of architecture, one of the most amazing inventions of the mankind. It is so universal that it has been used in architecture for nearly three thousand years.

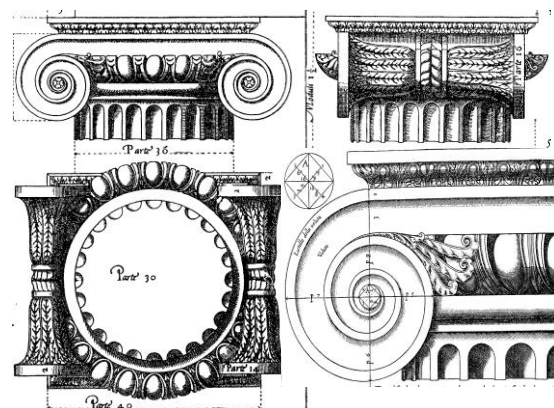

Fig. 2. Ionic order by Vignola

The system of orders was established in ancient times and was widespread in the global architectural practice, expressing the specificity of post and lintel system and most fully revealing its artistic and constructive nature. During this time, the image of capitals has transformed many times, but the original semantic meaning of the elements has remained unchanged. However, the role of detail is not sustainable even in the monostylistic domestic architecture. The decoration of individual elements is changing, but the essence, simple geometric volumes, remains constant.

Experience has shown that students can often make a mistake when drawing a capital from nature by measuring proportions and describing details. To avoid it, one can

first draw the frontal projection (facade) of the capital, and then, through constructing ellipses, build the volume. In addition, it is very important to understand the structural model, its spatial organization, geometric patterns and external plastic construction, its functions. It is essential to see and understand such features of form as geometric base, structural and plastic relationship of elements in general.

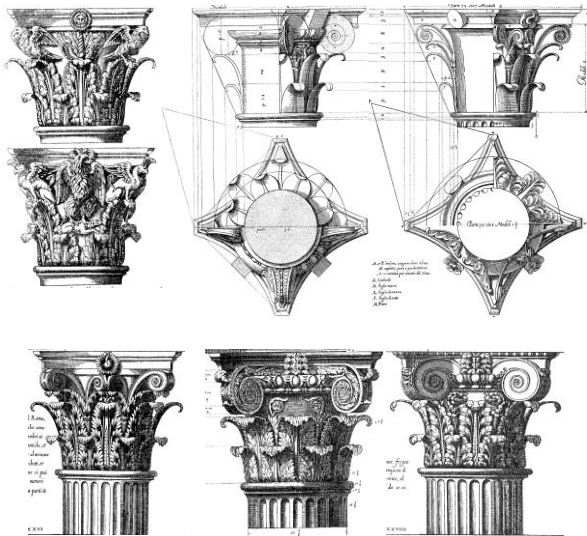

Fig. 3. Corinthian order by Vignola

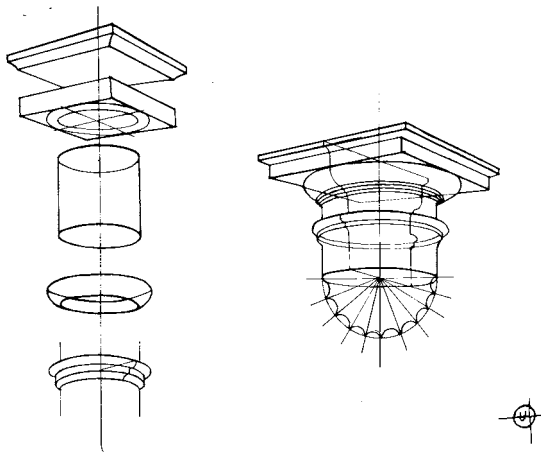

Fig. 4. Division of the Tuscan capital into simple geometric bodies

The stages of drawing capitals include: composition of picture position; identification of the main dimensions of the parts of the capital (vertical and horizontal directions); determination of the exact proportions; identification of the horizon line, the areas of the sides of a square plinth of an abacus; based on frontal projection, depiction of ellipses on the horizontal axes corresponding to the main segmentation of capitals; drawing the top ellipse of the echinus, drawing the ellipse of the echinus around the square of the abacus; drawing details of columns, analysis of their geometry of their own and falling shadows in accordance with the perspective; identification of the

main tonal relationships (identifying forms of capitals by means of light and shade, using the knowledge of the nature of light and shade on simple geometric forms) detailed study of chiaroscuro relations (tone, semitone, reflexes), detection of midtones and reflexes; revealing reflections; harmonious combination and subordination of all tonal relationships, using the tools of pencil graphics.

To illustrate the features of the shape of capitals, it is important to consider options for changing perspective regarding the horizon and abacus angle by rules of linear perspective: a) view when viewer is placed at the lowest point (called the frog perspective) b) view from the point of the horizon; c) the view above the horizon (bird's eye view).

III. Drawing of Tuscan and Doric Capitals

Drawing of Tuscan Capitals

The Tuscan capital consists of three main parts: a cylindrical barrel - a neckplate covered with a square on the top, an abacus (located symmetrically in the center on the top of the cylinder), an echinus - a convex molding, which has a cross section in the form of an ellipse and forms a transition between the curved shaft and the flat square abacus.

The abacus is a square plate with the top of an ogee molding with curved edges. The echinus, in turn, is supported by the shelf from the bottom. The transition from the echinus to the shaft can be carried out using the right angle or curved molding. The astragalus is a body formed by the movement of the ball in a circle at some distance from the cylinder surface and adjacent to the bottom shelf. Typically, the size of the abacus, the echinus and the neck in height is approximately equal.

Drawing capitals can be started from square plates of the abacus or the circle of the echinus top basis. The main thing is to build a combination of these two elements: inscribed in a square circle (in perspective), and regardless of the position of plate angles, the ellipse must be built strictly in a horizontal position using the rule of foreshortening. The middle of each side of the square plate must be confirmed with the convexity of the ellipse. It is unacceptable to try to fit the shape of an ellipse to the wrongly built square, which will lead to significant distortions of the entire image.

After finishing the construction of the abacus, we begin building a shaft. Our drawing should be based on the laws of linear perspective. If the capital is located highly above the horizon, there will be wider ellipses, circles that are closer to the horizon line will be projected in line and so on. It is also important to draw not only visible but also invisible elements of capitals, which helps to show the image volume and the construction of capitals.

Correlating the whole and partial proportions, it is important to refine their location based on logic constructive structure of elements and their parts. While working on a drawing, it is important to come closer to the depicted model to study the shape of parts, which helps to clarify the picture.

While drawing the pilaster capitals (half-forms), it is necessary to build the image of the whole form of the

capital, not just its visible part, then determine half of the capital and separate the halves of the ellipses due to perspective rules. After checking and making additional refinements, the unnecessary half can be weakened slightly, but do not get rid of it immediately.

Particular attention should be paid to the proportions, perspective, character, three-dimensional shape and the overall tone of the picture. After clarifying the construction and correcting errors, detect the volumetric form using light and shade. Firstly, identify the boundaries of their own and falling shadows, then put on light tone of gray areas, followed by the study of light and shade across the image and around it, gradually completing the picture.

Drawing of Doric Capitals

Harmony and conciseness, unity of shapes and constructive solutions make the Doric capital essential for the study by architecture students. The Doric capital is very similar to the Tuscan one, also containing such main elements as an echinus, an abacus and a neck, but differs in some decoration and molding. The shaft of the column contains twenty vertical flutes, to each of them correspond the ionics on the echinus of the capital and elongated element in the shaft. The Doric capital has some decorations, while the Tuscan one is plain, without decoration.

Considering the proportional features of the Doric capital and the choice of view point in academic settings, the capital is placed above the horizon. It is necessary to define the horizon line and points of foreshortening of capital lines and to determine all the features of proportional parts. To facilitate the construction of the geometrical perspective, all the invisible lines of the capital are also built of fine lines and remain visible to ease the comprehension of the capital's perspective in the process. At the final stage, volume and linear perspective are increased by gradation of the line width: visible lines and lines of the first plan are more active, contrast and thicker; lines on remote plans - less active; invisible lines - thin and weak. Volume of the capital is expressed by tonal means: the direction of light falling on the detail, its own and falling shades (shade from the abacus to the echinus, etc.) are determined.

Tonal processing of the Doric capital is quite similar to the Tuscan one. It is particularly important to be able to allocate the most contrast places, to make softer and tone down less contrast places. It is also necessary to choose the main direction of light - left or right from the capital. Front lighting visually makes form flat, indistinct, because beginners often depict shadows on the form, not the form itself. With properly selected light source, it is easier to determine the overall tonal scope of the drawing, recalling the principles of tonal shaping of simple forms: cylinder, cone, sphere, cube, and based on them - small parts such as ionics (convex ovoid shape spherical forms), beads (cylinders), flutes (hemispherical concave grooves). With the top lighting the shades will be the darkest; shadows on a plane inclined inward (the echinus of the capital) - lighter; shades on vertical planes (barrel capitals) - the lightest.

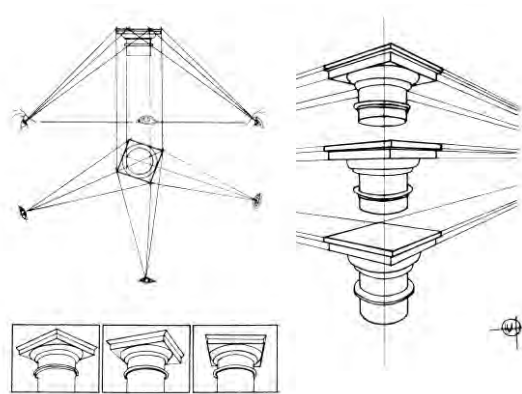

Fig. 5. Appearance of the Doric capital from different view points

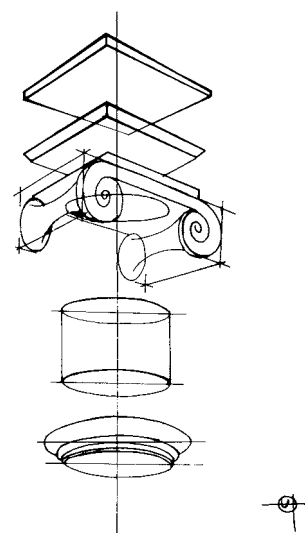

Fig. 6. Division of the Ionic capital into simple geometric bodies

IV. Drawing of Ionic capitals

The Ionic capital consists of three main elements - a barrel of a column (cylinder), an abacus (thickened square plate) and an echinus adhering to it (quaternary shaft). A distinctive feature of the Ionic capital is that two sides have one character of processing, the other two - another one.

Key elements of the Doric capital, such as an abacus, an echinus and an astragal also form the basis of the Ionic capital, but the shelf of its abacus seems to be stretched and wrapped in the spirals of the volutes. The ovolo molding of the echinus, treated with ionics, is partially closed by curls of volutes, and the junction of the echinus to the curls of volutes - by petals (palmetto). The spiral of the volute has three turns and comes to the center in the form of a small concave circle. The scrolls of balustrades on the side façade look as if they were tightened in the middle with a belt.

The barrel of the Ionic order column is usually treated with flutes, which are deeper than the Doric and separated from each other with stripes. The abacus has the shelf

supported by rings. The abacus with volutes is raised above the echinus, which extends from the front edge of the abacus, because it has a larger diameter than the length of the shelf of the abacus. Such construction is also an important feature of the Ionic capital compared with the construction of the Tuscan and Doric ones, and therefore there is greater difficulty in its drawing. The Ionic capitals also differ from the Doric by more intensive decoration of the surface with additional elements - ionics and volutes. This actually complicates the task of drawing capitals, because the decorative elements distract and interfere with the view of the main structural nature, which does not differ from the Doric one.

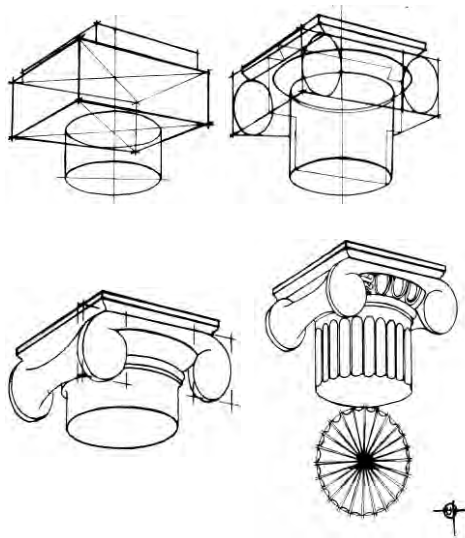

Fig. 7. Stages of constructing the Ionic capital

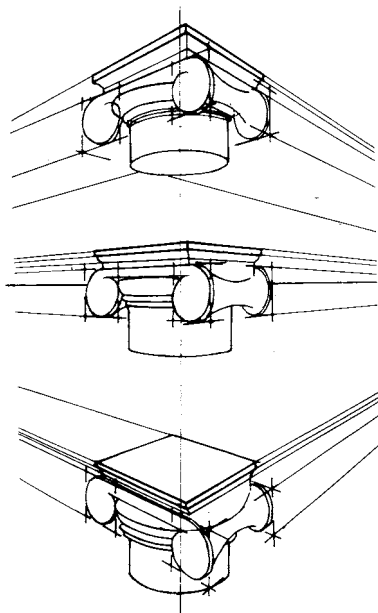

Fig. 8. Appearance of the Ionic capital from different view points

There is another important point. To properly draw the foreshortening of the visible part of the echinus between the volutes, it is necessary to identify its full form (as in

the Tuscan and Doric capitals) on the symmetry axis of the trunk, and then start laying out axes of ionics. It is important to remember the following provisions of proportions of certain parts of the form (at three times or normal distance) - they remain approximately in the same proportions as that they are in the frontal location. The Ionics has an ovoid shape with a cut-off top, framed by stylized leaves and separated by arrows. Then draw the contours of details of the ornament, specifying their proportions in accordance with the perspective, bringing the drawing to the stage of chiaroscuro study.

To draw the Ionic capital correctly, it is important to understand design patterns of building decorative details in relation to the constructive basis of the capital - a square base with a cylinder abacus string. If you mentally remove the parts, what remains is the constructive basis of the Doric capital: the trunk of the column and the abacus with the ovolo molding. This method gives a clear understanding of the fundamental design of capitals. Further details are specified later. Drawing the Ionic capital does not differ fundamentally from drawing the Doric or Tuscan ones. Firstly, we sketch the bulk of the capital on the centre line: the cylinder of the barrel and the abacus with volutes. The volutes can be represented collectively, being inscribed in a box, which height is equal to the height of volutes and seems to be threaded onto the shaft of the capital. On the front side (the long side of the parallelepiped), the size of volutes in width (it is smaller than the size in height) and the distance between them (it is about one and a half times the width of the volutes) are planned. Then, it is necessary to find the height of the echinus with the molding and the shelf underneath and identify the height of the abacus.

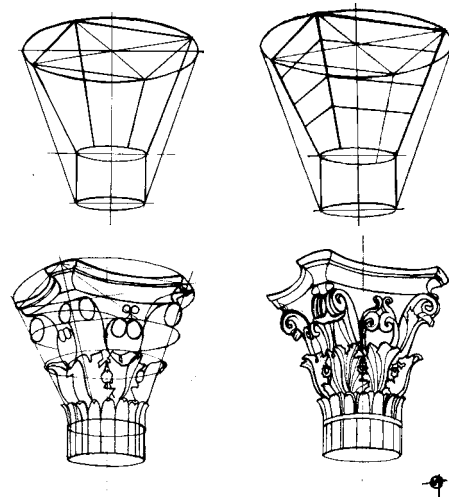

Fig. 9. Stages of constructing the Corinthian capital

The next step is to draw boxes reserved for the volutes, and inscribe the spirals of the volutes with foreshortening. It is important to remember that scrolls of balustrades on the side facade of the capital are shaped as a tubular cylinder and the thickness of the rim of volutes should be shown as the part of the cylinder for proper drawing of connections between external and internal contours. In addition, it is important to show the foreshortening of two cylinders, in which balustrades are inscribed.

Concerning the proportions of the Ionic capital, its height is $\frac{2}{3}$ module due to the absence of a necking. Its most difficult part is the volute. The abacus of the Ionic capital contains a thin plate, which has the ogee molding of the Greek orders, or the astragalus of the Romans. Its edges are moved from the axis of the column for one module. From the bottom of the echinus draw vertical lines, which will record the centers (eyes) of the volutes in relation to the axis of the column. The distance from the bottom of the abacus to the eyes is $\frac{1}{2}$ module or 9 parts (Module of the Ionic order has 18 parts). The bottom of the echinus is located on the distance of $\frac{2}{3}$ of the module from the abacus, and its height is $\frac{1}{3}$ module. The space between the abacus and the echinus is formed by balaustres. The eyes of volutes fix the position of the axes of balaustres.

After making this construction, we can draw volutes. Volute is a spiral that starts spinning from the eyes. Therefore, the outline of its outer surface will be formed by different distances from the center. The distance from highest point to the center is 9 parts, the distance from the outer point to the center is 8 parts .

In the construction of the half of the Ionic capital (pilaster capital), it is important to begin with the depiction of the contours of the whole shape, and then draw a symmetrical vertical cross-section, leaving the main half for further continuation of the work, and the supporting one - for further clarification of the main.

V. Drawing of Corinthian capitals

It is important to stress attention on the basic shape of the capital, to generalize and reject random elements, to combine the parts with the whole construction. The height of the Corinthian capital is equal to $2\frac{1}{3}$ module. $\frac{1}{3}$ of the module is the abacus. The diagonal of the abacus is 4 modules.

Four sides of the abacus are concaved in the middle. The abacus is supported by curls similar to volutes. The smaller curls are located in the circle of the abacus. Under the curls, there are two rows of leaves. The bottom row of leaves is twice at height, and their axes are located between the axes of the bottom row.

It is necessary to define the order of rows of acanthus leaves, volutes and various curls. In drawing decoratively rich capitals, it is important to understand their structural nature, base and parts of the general form. It is usually an inverted cutted cone or four-sided pyramid. Its top element, the abacus is the plate of a tricky configuration, which has a square form. This is clearly noticeable when considering the plate from the top, when all rough edges are equally distant from the center. To draw such capital, we should try to understand its construction features.

Therefore, the construction should be started from the halfway line – the axis of symmetry, as in constructing the Doric and Ionic capitals. In the construction of densely decorated capitals, it is important to understand the structural basis of the capital, which creates the full form.

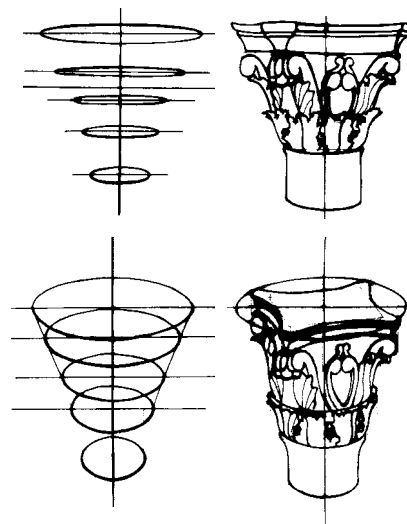

Fig. 10. The Corinthian capital from different points relative to the horizon

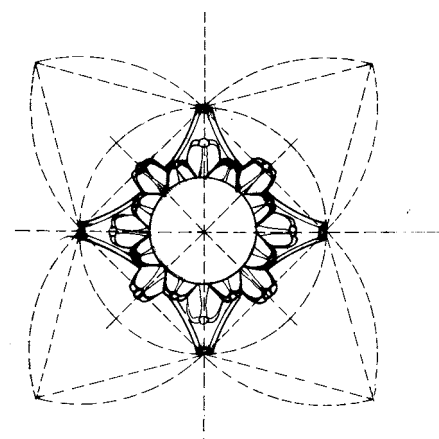

Fig. 11. Plan of Corinthian capital

VI. Conclusions

The research emphasizes the importance and value of studying capitals of classical architectural orders by drawing, which allows students to meaningfully analyze architectural forms, volume and space at the early stages of architectural activity. Therefore, it is important to learn to consciously see the constructive and geometrical base, three-dimensional shape, logically analyze and correctly represent them on the paper surface by using various graphical tools and techniques, with the knowledge of the rules of linear perspective, to be able to keep in unity the internal and external volume of forms.

In this article, the constructive forms of capitals have been analysed; the simple geometrical components and volumes of the shape have been determined; the methods of constructing capitals - from the total, common form to specific details – have been consistently described, taking into consideration interrelated issues of composition, proportion, perspective, lighting, light and shade, construction, plastic, tone, matching of components, which create a completed form; the graphical schemes of the Tuscan, Doric, Ionic and Corinthian capitals have been elaborated; the main features of modeling forms have been established.

References

- [1] T.M. Baran, Graphical schemes of construction of classical orders. Lviv, 2013.
- [2] O. B. Bilinska et.al., Rysunok arkhitekturnoi detali. Metodichni vказivky do dystsypliny “Rysunok, zhyvopys, skulptura” dlia studentiv I–III kursiv bazovoho napriamu 6.060102 “Arkhitektura” [Drawing architectural details. Guidelines for the discipline “Drawing, painting, sculpture” for the students of the I-III years of the direction 6.060102 “Architecture”]. Lviv: Vydavnytsvo Lvivskoi politekhniki Publ., 2013.
- [3] N. G. Li, Osnovy uchebnogo akademicheskogo risunka [Fundamentals of educational academic drawing]. M.: Jeksmo Publ., 2009.
- [4] O. I. Liaskovskiy, B. N. Skyba, Metodichni vказivky z kursivoi roboty “Rysunok, zhyvopys, skulptura” dlia studentiv I-IV kursiv bazovoho napriamku 6.1201 “Arkhitektura” [Guidelines for the course work “Drawing, painting, sculpture” for the students of the I-IV years of the direction 6.1201 “Architecture”]. Lviv: Vydavnytsvo Lvivskoi politekhniki Publ., 2003.
- [5] V. P. Mamugina, M. V. Nikol'skij, Risovanie geometricheskikh form i kompozicij [Drawing geometric shapes and compositions]. Tambov: Izdatel'stvo Tambovskogo gosudarstvennogo tehnikeskogo universiteta Publ., 2009.
- [6] M. L. Ovchinnikova, Risunok dlja dizajnerov 1 kursa [Drawing for the designers of the first year]. Vladivostok: Izdatel'stvo Vladivostokskogo gosudarstvennogo universiteta jekonomiki i servisa Publ., 2002.
- [7] Rysunok kapitely [Drawing capitals]. [Online]. Available: <http://urokizo.ru/risunok/risunok-kolonnyi-kapiteli/>. [Accessed: Sept. 10, 2013].
- [8] S. V. Tihonov, Risunok : uchebnoe posobie dlja vuzov [Drawing: Textbook for higher educational establishments]. M.: Strojizdat Publ., 2005.
- [9] O. V. Vdovytska et. al., Metodichni vказivky do praktychnykh zaniat, vykonannia kursivoi roboty i samostiinoi roboty z kursu “Arkhitekturne proektuvannia” (dlia studentiv 1 kursu dennoi formy navchannia napriamu 6.060102 - “Arkhitektura”) [Guidelines for the practical classes, course paper and independent work for the course “Architectural design”]. Kharkiv: KNAME, 2009.– 73s.
- [10] Dzh. B. Vin'ola, Pravilo pjati orderov arhitektury: Per. s ital. [The rule of five orders of architecture: Translated from Italian]. M.: Izdatel'stvo Vsesojuznoj Akademii Arhitektury Publ., 1939.