

INDIRECT DETERMINATION OF ENERGY DATA AND OUTPUT POWER OF AN INDUCTION MOTOR

Mykhaylo Zagirnyak, Andrii Kalinov, Anna Kostenko, Igor Nesterov

Kremenchuk Ostrohradskyi National University, Kremenchuk, Ukraine
mzagirn@kdu.edu.ua, scenter@kdu.edu.ua, annakostenko.knu@gmail.com

© Zagirnyak M., Kalinov A., Kostenko A., Nesterov I., 2014

Abstract: A method for indirect determination of energy data and output power on the shaft of an induction motor (IM) is presented. It is demonstrated that the application of the proposed method makes it possible to estimate power efficiency of IM operation without its withdrawal from the manufacturing process with minimum information about electric drive (ED) parameters and under the conditions of the impossibility of using power equipment for the creation of special operating conditions and testing actions. The possibility of the calculation of IM output power both under static and dynamic conditions on the basis of the motor constant losses determined for an idle mode without their division into core losses and losses in mechanical assemblies is substantiated. Experimental research has proved the efficiency and sufficient accuracy of the proposed method for the calculation of IM output power.

Key words: induction motor, energy data, output power, power components, losses.

1. Introduction

Objective estimation and improvement of power efficiency of the IM contained in a variable-frequency ED is impossible without accurate data about its real energy parameters and output power [1]. Efficiency and a power coefficient ($\cos(\varphi)$) are basic conventional energy data. For their determination it is necessary to know the losses in the basic structural elements and in the whole machine. Energy data of the IM and the whole ED significantly depend on the conditions of its operation, on the load moment, angular speed, mains voltage and frequency.

Modern means of control and diagnostics based on measuring electric machine parameters provide the possibility for controlling the state of both mechanical and electromagnetic systems of electric drives. However, most of these methods imply the use of expensive measuring diagnostic equipment, partial dismantling or withdrawal of the diagnosed power equipment from the manufacturing process to perform testing at specialized stands.

During operation of a number of EDs the problem of determination of real energy data of the IM or its current

load under the conditions of minimum information about ED parameters and without its withdrawal from the manufacturing process often arises. If a sufficiently developed electrotechnical laboratory and mobile computer-aided measuring equipment are available at the enterprise, measurement of the object without its disconnection does not present any essential problem. However, regulations related to testing processes [2 – 4] do not allow the determination of output power of the IM and its energy data without testing with specialized equipment.

Paper [5] contains the algorithm of determination of IM energy data on the basis of instantaneous signals of stator phase currents and voltages which can be measured and fixed quite easily and without the motor withdrawal from the manufacturing process. However, this method requires information about core losses and some parameters of an IM equivalent circuit (EC), such as active resistances and inductions of stator phase windings. Usually this information, as well as information about rated data of the researched motor is not available.

2. Theoretical research

When a method for determination of the output power of the IM and its energy data is created and there is no information on the motor parameters, the following assumptions of measurement possibilities are made: a) testing during idle mode operation and under load (nominal and close to it); b) measurement of active resistances of stator phases when the motor is cold or heated; c) measurement of currents and voltages of stator phases and measurement of angular rotation frequency of the rotor.

The main idea of the method consists in the use of idle mode to determine constant motor losses without their division into core losses and losses at mechanical assemblies. Constant losses determined by this method are used later in calculation of IM output power during on-load operation mode.

It is known that IM output power can be determined from the equation of power balance [6]. In a general case the balance can be presented according to instantaneous values of power components:

$$p_2(t) = p_{em}(t)(1 - s(t)) - \Delta p_{f/w} - \Delta p_{ad}(t), \quad (1)$$

where $p_{em}(t)$ is electromagnetic power;

$\Delta p_{f/w}$ are friction and windage losses; $\Delta p_{ad}(t)$ are additional losses; $s(t)$ is slip.

In this case electromagnetic power is equal to:

$$p_{em}(t) = p_1(t) - \Delta p_{Cu1}(t) - \Delta p_c(t), \quad (2)$$

where $p_1(t) = u_A(t)i_A(t) + u_B(t)i_B(t) + u_C(t)i_C(t)$ is input power; $\Delta p_{Cu1}(t)$ are copper losses; $\Delta p_c(t)$ are core losses; $u_A(t), u_B(t), u_C(t), i_A(t), i_B(t), i_C(t)$ are voltages and currents of corresponding stator phases.

Then, taking (2) into account, output power is:

$$p_2(t) = p_1(t) - \Delta p_{f/w}(t) - \Delta p_{ad}(t) - \Delta p_{Cu1}(t) - \Delta p_c(t) - p_1(t)s(t) + s(t)(\Delta p_{Cu1}(t) + \Delta p_c(t)). \quad (3)$$

The analysis of expression (3) for a wide range of powers of conventional IMs has demonstrated that the component $s(t)(\Delta p_{Cu1}(t) + \Delta p_c(t))$ can be neglected as insignificant in comparison with other components. So, for the IM of a medium or high power P_r in a steady operation state with nominal slip s_r a component $\frac{s(\Delta p_{Cu1} + \Delta p_c)}{P_1} 100\% \leq 1\%$, where P_1 is an average value of $\Delta p_1(t)$, Δp_{Cu1} is an average value of $\Delta p_{Cu1}(t)$ and Δp_c is an average value of $\Delta p_c(t)$, (Table. 1).

Table 1

Analysis of input power components

Parameter	Motor	$P_r = 30$ kW, $s_r = 0.023$	$P_r = 160$ kW $s_r = 0.014$
$\frac{s(\Delta p_{Cu1} + \Delta p_c)}{P_1}, \%$		0.16	0.1

Thus, output power is:

$$p_2(t) = p_1(t) - \Delta p_{f/w}(t) - \Delta p_{ad}(t) - \Delta p_{Cu1}(t) - \Delta p_c(t) - p_1(t)s(t). \quad (4)$$

The components of equation (4) can be expressed through idle mode power as all input power in the idle mode is consumed by losses in motor mounts:

$$p_{1id}(t) = \Delta p_{id}(t) = \Delta p_{f/w} + \Delta p_{ad}(t) + \Delta p_c(t) + \Delta p_{Cu1id}(t), \quad (5)$$

where $\Delta p_{Cu1id}(t) = i_{Aid}^2(t)R_A + i_{Bid}^2(t)R_B + i_{Cid}^2(t)R_C$ denotes electric copper losses in the idle mode; $i_{Aid}(t), i_{Bid}(t), i_{Cid}(t)$ are currents of corresponding stator phases in the idle mode; R_A, R_B, R_C are active resistances of corresponding stator phases.

Let us assume that all components of expression (5), except copper losses, are constant and do not depend on the load. Then on the basis of the mentioned above and knowing instantaneous input power in the idle mode:

$$p_{1id}(t) = u_{Aid}(t)i_{Aid}(t) + u_{Bid}(t)i_{Bid}(t) + u_{Cid}(t)i_{Cid}(t), \quad (6)$$

which is calculated using instantaneous values of IM stator voltages and currents, it is possible to write down the equation for IM constant losses which do not depend on the load:

$$\Delta p_k(t) = p_{1id}(t) - \Delta p_{Cu1id}(t) = \Delta p_{f/w} + \Delta p_{ad}(t) + \Delta p_c(t). \quad (7)$$

Taking (7) into account, IM output power:

$$p_2(t) = p_1(t)(1 - s(t)) - \Delta p_{Cu1id}(t) - \Delta p_k(t), \quad (8)$$

where $\Delta p_{Cu1id}(t) = i_{Aid}^2(t)R_A + i_{Bid}^2(t)R_B + i_{Cid}^2(t)R_C$ are electric copper losses in on-load operation; $i_{Aid}(t), i_{Bid}(t), i_{Cid}(t)$ are currents of corresponding stator phases on-load.

Motor shaft moment can be calculated using the expression:

$$T(t) = \frac{p_2(t)}{\omega(t)}, \quad (9)$$

where $\omega(t)$ is angular rotation frequency.

The calculation of the mentioned power parameters showed the sufficient accuracy of the method. For example, the error of determining IM output power does not exceed 5% and for motors of the power higher than 160 kW it approaches 1% (Table 2).

Table 2

Errors of calculation of power P_2

Parameter	Motor	$P_r = 30$ kW, $s_r = 0.023$	$P_r = 160$ kW $s_r = 0.014$
Error of calculation of output power $P_2, \%$		2.1	1.03

The efficiency of an electric drive during an operation cycle is determined according to found output power $p_2(t)$ and measured input power by expression [5].

$$\eta = \frac{\int_0^{T_c} p_2(t) dt}{\int_0^{T_c} p_1(t) dt}, \quad (10)$$

where T_c is cycle time.

Fig. 1 contains the algorithm of the calculation of IM energy data for a general case using instantaneous values of ED ($s(t), u_A(t), u_B(t), u_C(t), i_A(t), i_B(t), i_C(t)$), components of input power ($p_1(t), p_{1id}(t)$) and power losses ($p_{Cu1}(t), \Delta p_{Cu1id}(t), \Delta p_{Cu1}(t), \Delta p_k(t)$). By averaging the calculated energy data and power losses during the voltage cycle of the supply mains it is possible to pass to their integral values.

The proposed method has some advantages. There is no necessity of determining all EC parameters, except active resistances of stator phases, and carrying out a classical experiment in the idle mode with variation of supply voltage. There is no need either to withdraw the IM from the manufacturing process or to apply equipment for the creation of special testing actions.

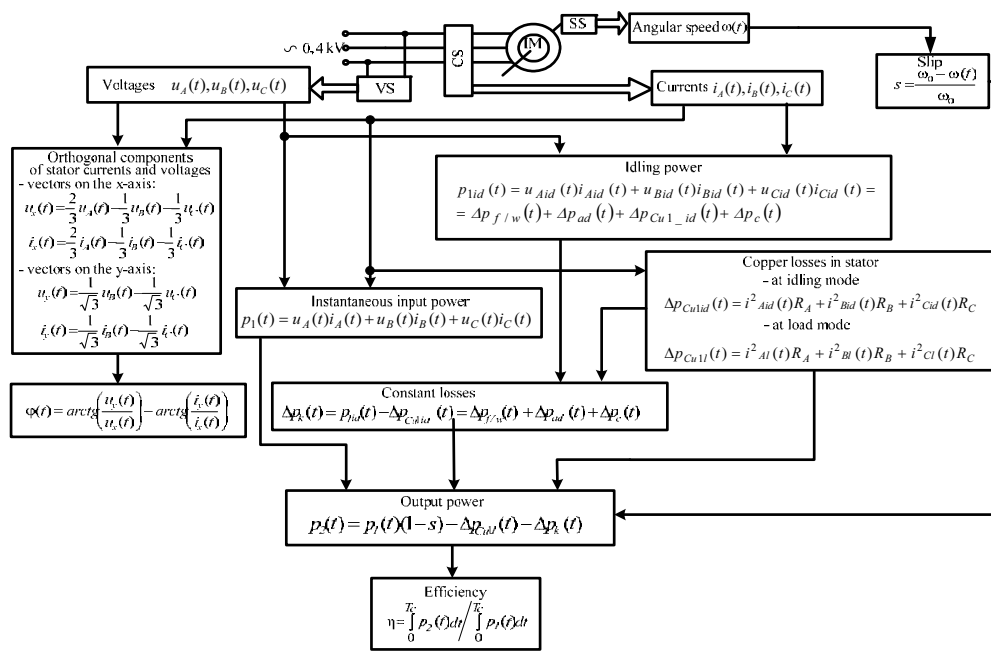

Fig. 1. Algorithm of indirect determination of energy data and output power of induction motors under the conditions of a manufacturing process.

3. Experimental results

To confirm theoretical theses the method of calculation of output power was verified by experiment. To realize measurements of the required parameters a mobile measuring complex was used (Fig. 2) [7]. Current was measured by means of current pincers-adapter with analog output ATA-2504. Angular rotation frequency was measured with the use of an encoder E40S T-24 and also by a contactless method using optical tachometer TX01. Application of current pincers-adapters allows measuring without the break of power circuits of IM supply.

Using the encoder together with the corresponding unit of software makes the measurements of instantaneous values of rotation frequency more accurate in comparison with tachogenerators, even with a small number of impulses per revolution (100 imp/rev). Measurements of winding active resistances were carried out with the use of a measuring bridge according to [3].

Experiments were made with AIR80V4U2 IM ($P_r = 1.5$ kW; $I_r = 6.3/3.6$ A; $\eta_r = 77$ %; $n_r = 1395$ rpm; $\cos(\varphi_r) = 0,81$; operation mode S1; insulation class F1; nominal excess of the insulation temperature 155 °C; nominal total losses $\Delta P_{\Sigma r} = 448$ W). The analyzed IM was loaded by a direct current generator with an adjustable voltage source of an exciting winding.

The diagrams of transient processes according to the current of a phase A, vectors of current and voltage when the IM is started without load (Fig. 3) and transient processes according to electromagnetic moment and

angular rotation frequency (Fig. 4) are given as the examples of measurements and processing of the measured data.

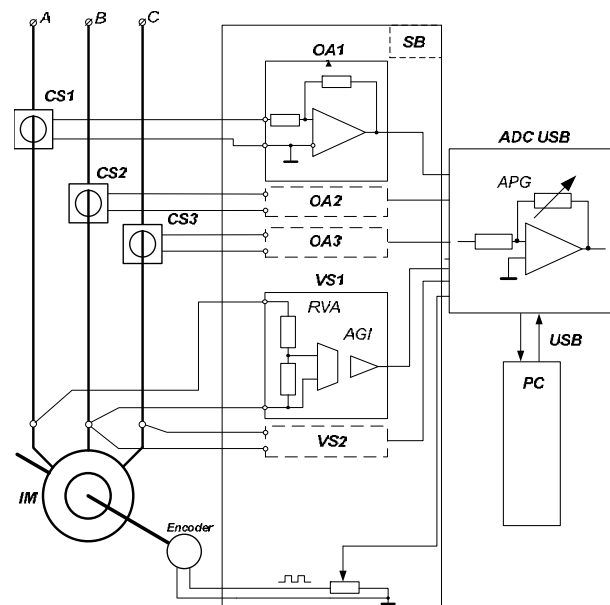

Fig. 2. Structural circuit of a measuring complex: SB – sensors block; VS – voltage sensor; RVA – resistive voltage attenuator; AGI – amplifier with galvanic isolation; CS – current sensor ATA 2504; OA – operational amplifier; IM – induction motor; ADC – analog-to-digital converter; APG – amplifier with programmable gain; PC – personal computer; USB – PC bus.

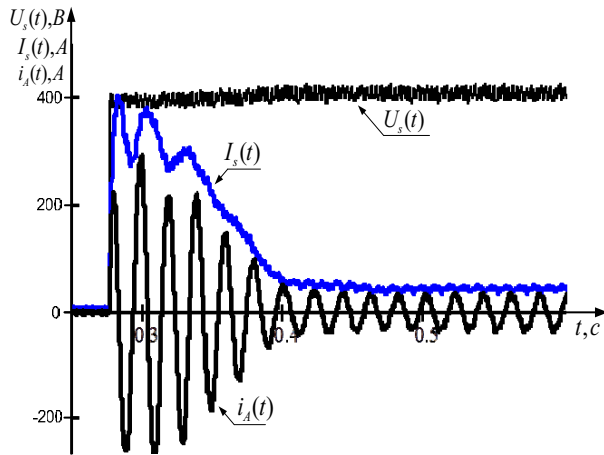

Fig. 3. Transient processes according to phase A current $i_A(t)$, current $I_s(t)$ and voltage vectors $U_s(t)$ when IM is started without load.

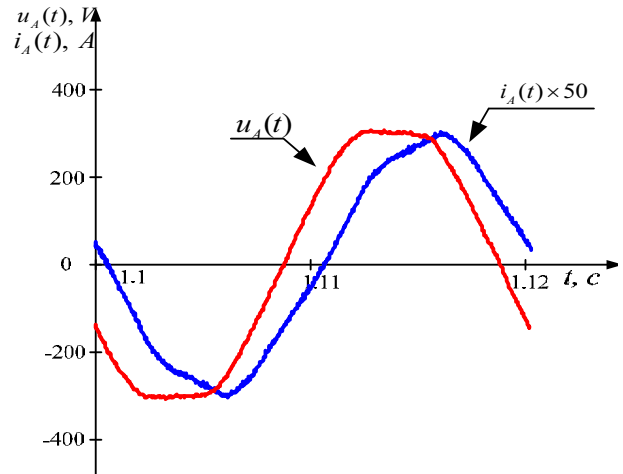

Fig. 6. Current $i_A(t)$ and voltage $u_A(t)$ of phase A of IM stator on-load.

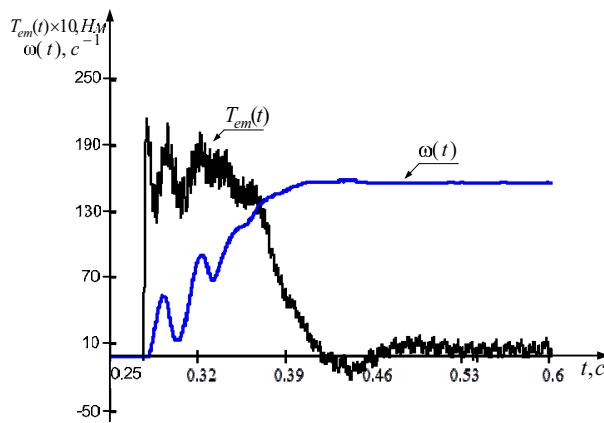

Fig. 4. Transient processes according to electromagnetic moment $T_{em}(t)$ and angular rotation frequency $\omega(t)$.

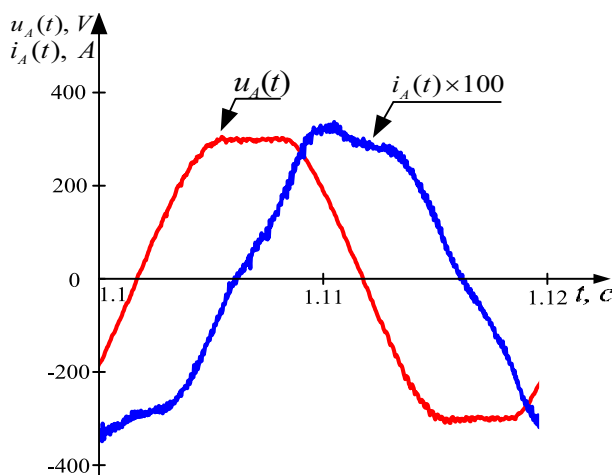

Fig. 5. Current $i_A(t)$ and voltage $u_A(t)$ of phase A of IM stator in idle mode.

Figs. 5, 6 show signals of the current of the phase A and voltage in the idle mode and on-load.

The results of experiments on IM operation in the idle mode and on-load mode are given in Table 3:

Table 3

Results of processing experimental data of the method of determination of IM energy data

Parameter	Mode	
	idling	load
measured parameters		
I_{rmsA}, A	2.217	4.094
I_{rmsB}, A	2.191	4.29
I_{rmsC}, A	2.168	4.15
R_{ϕ}, Ohm	5.068	7.957
n, rpm	1494	1400
Calculated parameters		
s	0.004	0.067
P_1, W	189.93	$2.445 \cdot 10^3$
$\Delta P_{Cub}, W$	73.15	418.42
$P_1 - P_{Cub}, W$	116.78	$2.027 \cdot 10^3$
$\cos(\varphi_r)$	0.157	0.842
$\Delta t, ^\circ C$	17.3	143.64
P_2, W	–	$1.746 \cdot 10^3$
T, Nm	–	11.92
$\eta, \%$	–	71.4

The analysis of the calculated parameters of the on-load operation demonstrates that stiffness of mechanical characteristic of the analyzed IM essentially exceeds the stability of the characteristic that can be determined on the basis of rated data. Due to this fact, when the experiment of IM on-load operation with the angular rotation frequency approaching the nominal one was made, the motor was overloaded by 16.4% compared with the rated output power.

To provide a possibility of comparing the results obtained the experiment on the idle mode with the variation of the amplitude of supply voltage and the experiment of a short circuit were carried out according to [2, 6]. The results of the experiment on the idle mode

were used to determine losses in mechanical units $\Delta P_{f/w} = 70.31$ W (which makes 4.7% of the nominal power) and constant losses $\Delta P_c = 45.54$ W (which makes about 10% of IM nominal total losses). The determination of power loss components during the experiment of the idle mode allowed the determination of IM output power on-load which made 1771.2 W.

The comparison of the values of output power calculated according to the proposed method (Tab. 3) and according to classical equations of IM power balance with the use of losses determined in the idle mode and the short circuit mode [6] demonstrated discrepancy of less than 2%. The analysis showed that the greater IM rated power, the smaller the value of the error is. It should be noted that the accuracy of calculation during the realization of the method significantly depends on the accuracy of measurement of IM stator active resistances, especially after carrying out the experiment on-load.

4. Conclusion

A method for indirect determination of energy data and output power of an induction motor, making it possible to estimate its power efficiency under the condition of minimum available information on the electric drive parameters has been proposed. The experimental verification of the method has demonstrated that the error of determination of the output power of the analyzed induction motor does not exceed 2%. The greater the nominal power of the analyzed motor becomes, the smaller the value of the error is. The advantages of the described method include: a possibility of its application without the withdrawal of the equipment from the manufacturing process; the necessity of minimum information on the parameters of the motor equivalent circuit; application under the condition of practical impossibility of using power equipment for the creation of special modes of operation and special testing actions; the necessity of the measurement of a minimum number of values to perform further calculations.

References

- [1] B. Blanus, "New Trends in Efficiency Optimization of Induction Motor Drives." In Meng Joo Er, eds, *New Trends in Technologies: Devices, Computer, Communication and Industrial Systems*, pp. 341–358, InTech, 2010.
- [2] *IEEE Std 112-B, 1996: IEEE Standard Test Procedure for Polyphase Induction Motors and Generators*. New York, USA: IEEE Power Eng. Society.
- [3] *IEC Std 60034-2: 1972. Rotating electrical machines - Part 2: Methods for determining losses and efficiency of electrical machinery from tests (excluding machines for traction vehicles) with amendments 1: 1995 and 2: 1996.*
- [4] *IEC Std 61972: 2000. Method for determining losses and efficiency of three phase, cage induction motors.*
- [5] A. Kalinov, D. Mamchur, and A. Chumachova, "Research of the Asynchronous Motor's Observability for Estimation Operating Conditions And Energy Efficiency," in *X International PhD Workshop OWD 2008, Conference Arhives PTETiS*, vol. 26, pp. 357–362, Poland, 2008.
- [6] A. Ivanov-Smolenskiy, *Electrical machines*, vol. 2, Moscow, Russia: Mir, 1983.
- [7] A. Kalinov and A. Gladyr, "Universal teaching and research equipment for electromechanical laboratories", *Elektromekhanichni i energozberihayuchi systemy*, vol 3, pp. 14–19, Kremenchuk, Ukraine: KDPU, 2007. (Russian).

НЕПРЯМЕ ВИЗНАЧЕННЯ ЕНЕРГЕТИЧНИХ ПОКАЗНИКІВ І ПОТУЖНОСТІ НА ВАЛУ АСИНХРОННОГО ДВИГУНА

Михайло Загірняк, Андрій Калінов,
Анна Костенко, Ігор Нестеров

Представлено метод непрямого визначення енергетичних показників та потужності на валу асинхронного двигуна (АД). Показано, що застосування цього методу дає змогу оцінити енергетичну ефективність роботи АД без вилучення його із технологічного процесу за мінімальної можливої інформації про параметри електроприводу (ЕП) і в умовах практичної неможливості використання силового обладнання для створення спеціальних режимів роботи і тестових впливів. Обґрунтовано можливість розрахунку потужності на валу АД як в статичних, так і в динамічних режимах, на базі постійних втрат двигуна, що визначаються у режимі холостого ходу, без їх поділу на втрати в сталі і втрати в механічних вузлах. Експериментальні дослідження довели точність і ефективність запропонованого методу при розрахунку потужності на валу АД.



Mykhaylo Zagirnyak –

Corresponding Member of the National Academy of Pedagogical Sciences of Ukraine; Honored Scientist and Engineer of Ukraine; Doctor of Sciences (Engineering), professor, rector of Kremenchuk Mykhailo Ostrohradskyi National University, Ukraine; Head of the Department of Electric Machines and Apparatus of Kremenchuk Mykhailo Ostrohradskyi National University, Ukraine. Author of more than 400 papers, including six monographs, eight brochures, four manuals, and nine textbooks approved by the Ministry of Education and Science of Ukraine; 41 inventor's certificates and 28 patents for inventions.



Andrii Kalinov – Ph. D (Engineering), Associate Professor of the Department of Automated Control Systems and Electric Drive of Kremenchuk Mykhailo Ostrohradskyi National University, Ukraine. Author of more than 80 papers and 12 patents for inventions and utility models.



Ihor Nesterov – undergraduate student at the Department of Automated Control Systems and Electric Drive of Kremenchuk Mykhailo Ostrohradskyi National University. Author of three papers and one patent for a utility model.



Anna Kostenko – postgraduate student at the Department of Automated Control Systems and Electric Drive of Kremenchuk Mykhailo Ostrohradskyi National University, Ukraine. Author of 14 papers and three patents for utility models.