

## MATHEMATICAL MODEL OF DYNAMIC PROCESSES DURING FRICTION HARDENING OF FLAT SURFACES

© Gurey V., Korendiy V., Dmyterko P., 2014

**Представлена математична модель динамічних процесів, які виникають у разі фрикційного зміцнення плоских поверхонь деталей машин з використанням інструмента з нарізаними поперечними пазами на його робочій частині.**

**The mathematical model of dynamic processes which arise during frictional hardening of the flat surfaces of machine parts using the tool with transverse grooves cut into the working surface is presented.**

**Introduction.** Finishing processing significantly affects the quality indicators of the mechanisms i.e. reliability, working capacity, as well as technical and economic characteristics. The durability of assembly parts of machines depends on the quality of the parts' processing and condition of their surface layer that is formed during the finishing operations of manufacturing process. The condition of the surface determines the operational characteristics of the assembly parts of machines that are defined by geometric (macro-deviations, waviness, roughness) and physical-mechanical (microhardness, residual stresses, structure) characteristics and relative position of the microscopic inequalities on the contacting surfaces. All these parameters depend on the processing technology of parts and the assembly process of products. The use of surface hardening allows to reduce the speed of wearing off and to increase the life of the product. Ways of hardening may affect both the microgeometry of the surface, and the physical and chemical properties at the volume of surface metals, their structure and phase composition, which determines the state of the surface layer. It is known that the mechanical properties of materials are associated with the initial microstructure, while operating properties are determined by the dynamic structure that is formed during deformation. Insufficient consideration of this factor significantly limits targeted management of the structure and properties of the surface layers of assembly parts and makes it virtually impossible to obtain products with desired characteristics [1].

**Problem statement and analysis of known research and publications.** To strengthen the working surfaces of machine parts various surface treatment methods are used. One of these methods is the frictional hardening, which belongs to the methods of surface treatment using sources with high concentration of energy. The source of concentrated energy occurs in the contact zone between the working disc-tool and the processed surface of the assembly part during high-speed friction. In the contact zone of the tool and the assembly part fast heating and shear deformation of the surface layer take place simultaneously. The surface layer of the metal is heated to a temperature above the phase transitions ( $A_{c3}$ ). Due to the removal of the heat into the depth of the metal a fast cooling occurs in the surface layer and the formation of nanocrystalline white layer [2].

The process of frictional hardening of the working surfaces of the assembly parts of machines is as in terms of kinematics similar to the grinding process. At the same time, the formation of nanocrystalline hardened layer during friction hardening workflow is different from the process of grinding for power,

temperature interactions that occur in the contact zone of the tool and the assembly part. While enhancing frictional virtually almost no cutting of the surface layer happens, the process of high-speed friction in the contact zone between the tool and the assembly part causes intense shear deformation of the surface layer. The study of frictional hardening has been carried out in terms of materials, such as the formation of hardened layer, its properties and influence of hardened layer on durability. Currently, the study of dynamic processes during frictional hardening of the machine assembly parts is missing [1; 2].

**Formulation of research purposes.** The purpose of this study was to develop a mathematical model of the dynamic processes that occur during frictional hardening the surface layers of flat surfaces of machine assembly parts.

**Body part.** Friction hardening in the principle of its performance is similar to grinding. Therefore, flat- or circular grinding machines or specially designed machines or equipment can be applied. Friction hardening has been performed on a modernized flat grinding machine by KNUTH model HFS 3063 VS. Key diagram of surface grinding machine for frictional hardening of flat surfaces shown in Fig. 1. For the friction hardening the linear velocity at the periphery of the tool  $V_t=60-80$  m/s is necessary. To do this, we modernized the main motor unit of the machine. We replaced the alternating-current motor with a direct-current motor with more speed and more power; other functional movements of the machine were left unchanged. Instead of an abrasive disc, a metal tool-disc made of stainless steel 12X18H10T was installed. The diameter of the tool-disc was  $\varnothing 360$  mm. The metal disc has been installed onto the faceplate, which is part of the machine set. Before the installation of the tool-disc to the machine, its static balancing has been performed. For the balancing, a device that is used for balancing of abrasive tools has been used.

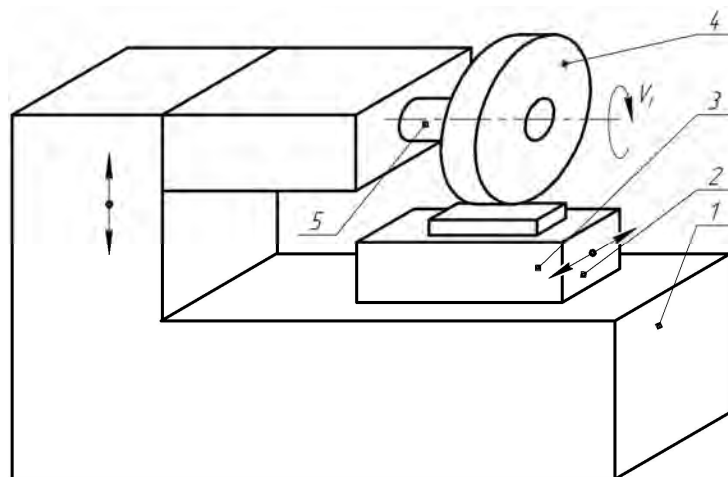

Fig. 1. Key diagram of surface grinding machine for frictional hardening of flat surfaces.  
1 – housing; 2 – machine table; 3 – assembly parts; 4 – tool-disc; 5 – spindle.

To increase the shear deformation in the surface layers of the assembly parts in the contact zone between the tool and the part during frictional hardening, a tool with transverse grooves cut into the working surface has been used (Fig. 2). The width of the groove was chosen from the condition of guaranteed full disengagement of the tool-disc and the assembly part. When the smooth part of the tool-disc touches the surface first there appears an impulsive load of the contact area and then a friction. After the disengagement of the contact, when the groove is above the smooth surface of the part, the contact zone unloads drastically. In the surface layer of the processed metal the following processes take place: heating due to high-speed friction; impulsive load during regular contact with the smooth part; cyclic heating and cooling; cyclic deformation in both normal and tangential directions. Number of grooves that are cut in the working zone, determine the correlation of the length of the smooth part and the width of the groove on the working part of the tool-disc. As the number of grooves increases, increases the frequency of impulse loading in the contact area between the tool and the assembly part that leads to the grinding of metal structure and formation of nanocrystalline surface layer of the processed part.

Imagine the system of flat surface grinding machine as multi-mass mechanical system. For this reason we divide the machine into several units (spindle, part, machine table, housinf) each with its own mass. In addition, one of the parts can be conditionally accepted with infinite mass; all other parts will be assembled to it. The design model of elastic surface-grinding machine can be represented as a two-mass mechanical model (Fig. 3). As part with infinite mass we accept the housinf, which is fixed and to which all other masses will be tied. The interaction between the individual masses we describe with two types of coupling: elastic coupling which is characterized by stiffness and damper coupling, which is characterized by the damping coefficients. The described elastic system allows movement along the horizontal and vertical axes. The tool-disc has a rotating movement, the axis of the spindle is fixed; the processed assembly part moves in the longitudinal direction. Normal and tangential component of the force of interaction of the tool and the processed assembly part surface in the area of contact will be considered as the excitation force. The working surface of the tool is discontinuous, with transverse grooves the number of which ( $n$ ) is to be even, cut in its working surface. The width of the groove is determined by the angle  $\varphi_g$ . The grooves divide the working part of the tool-disc into segments consisting of a smooth part and a groove. The length of the segment is determined by the angle  $\varphi_s$ . The ratio of the smooth surface to the groove is defined by the ratio of corresponding angles. We will model the interaction between the assembly part and the tool (vertical) as contact stiffness and power damping of local elastic-plastic deformation of the assembly part's surface.

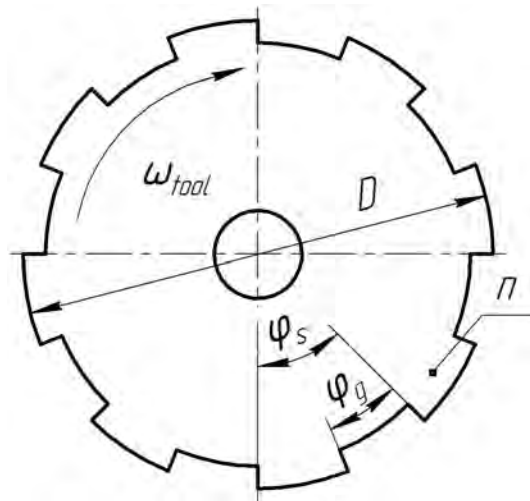

Fig. 2. Geometric parameters of the tool for frictional processing

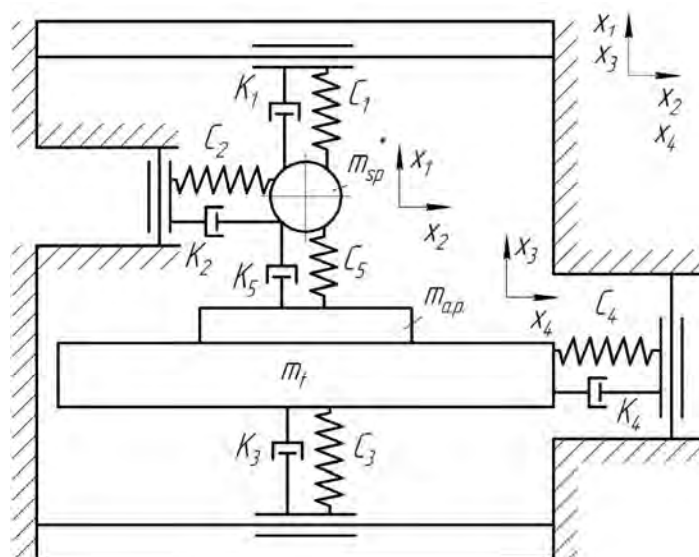

Fig. 3. Cyclic circuit of the machine's oscillations

Mechanical system of the machine has four degrees of freedom: movement of the spindle and the assembly part together with the table in the horizontal and vertical planes. As generalized coordinates, the relevant linear movement of the spindle and the table with the assemble part were taken. The differential equations that describe the motion of the system that are based on Lagrange equations of the second kind [3] have the following form:

$$\frac{d}{dt} \left( \frac{\partial E_k}{\partial \dot{x}_i} \right) - \frac{\partial E_k}{\partial x_i} + \frac{\partial E_p}{\partial x_i} + \frac{\partial \Phi}{\partial \dot{x}_i} = Q_{x_i}, \quad i = 1 \dots 4 \quad (1)$$

where  $E_k$  – kinetic energy of the system;  $E_p$  – potential energy of the system;  $\Phi_d$  – function of the energy dissipation in the system (Rayleigh dissipation function);  $Q_{x_i}$  – generalized forces corresponding to the chosen generalized coordinates  $x_i$ .

When formulating a mathematical model we make the following assumption: we assume that the variation in the stiffness of elastic elements does not exceed the linear and corresponds with the Hooke's law. This is justified by the conditions for the implementation of small deviations from the equilibrium position of the spring; we consider the mechanical system of the machine as being composed of rigid bodies connected by ideal holonomic constraints and elastic elements with strictly defined stiffness; into the dynamic model we will introduce viscous friction coefficients in form of dampers, which are proportional to the velocity of the moving sliders along the respective guiding axis and reflect energy dissipation in the corresponding elastic elements of the system [3].

The pinning force (normal pressure) between the surfaces of the tool to the assembly part and the friction between the surfaces of contact will be active in the system. Exposure to the active work force is equal to:

$$\sum_{k=1}^2 dA(\vec{F}_k) = dA(F_{p.f.}) + dA(F_{fr}); \quad (2)$$

$$dA(F_{p.f.}) = F_{p.f.} \cdot (-dx_1 + dx_3); \quad dA(F_{fr}) = F_{fr} \cdot (dx_2 + dx_4);$$

where  $F_{p.f.}$  is the pinning force (normal pressure) between the surfaces of tools and the assembly part;  $F_{fr}$  is the friction that occurs as a result of the force of normal pressure between the moving surfaces of the tool and the assembly part.

Analytical dependences for establishing appropriate generalized forces  $Q_{x_i}$  are as follows:

$$Q_{x_1} = Q_{x_3} = \begin{cases} \Delta x \cdot \frac{c_1 \cdot c_3 \cdot c_5}{c_3 \cdot c_5 + c_1 \cdot c_5 + c_1 \cdot c_3}, & wt = (0 \dots j \dots g) + \frac{2p}{n} \cdot j; \\ \left( \Delta x - (R - R \cdot \cos(wt)) \right) \cdot \frac{c_1 \cdot c_3 \cdot c_5}{c_3 \cdot c_5 + c_1 \cdot c_5 + c_1 \cdot c_3}, & \left| wt = (j \dots g \dots j \dots s) + \frac{2p}{n} \cdot j, \right. \\ \left. \left[ 0, \left( \Delta x - (R - R \cdot \cos(wt)) \right) < 0, \right. \right. \end{cases} \quad (3)$$

$$j = 0, 1, 2, \dots, n-1,$$

$$Q_{x_2} = -Q_{x_4} = F_T = Q_{x_1} \cdot f = Q_{x_3} \cdot f. \quad (4)$$

where  $c_1$  – stiffness of the machine spindle in vertical direction;  $c_2$  – stiffness of the machine spindle in horizontal direction;  $c_3$  – stiffness of the machine table in vertical direction;  $c_4$  – stiffness of the machine table spindle in horizontal direction;  $c_5$  – contact stiffness between the tool and assembly part;  $f$  – coefficient of friction between the materials of tool and the assembly part,  $n$  – number of grooves that cutting on the working part of the tool.

Kinetic energy of the system (fig. 3) we will define as the sum of four summands, taking into account the rectilinear motion of the spindle and the table in the vertical and horizontal planes:

$$E_k = \frac{m_{sp}^*}{2} \cdot (\dot{x}_1^2 + \dot{x}_2^2) + \frac{m_{a.p.} + m_t}{2} \cdot (\dot{x}_3^2 + \dot{x}_4^2); \quad (5)$$

where  $m_{sp}^*$  – weight of the machine spindle with weight of the tool;  $m_{a.p.}$  – weight of the assembly part;  $m_t$  – weight of the machining attachment.

Weight of the machine spindle with weight of the tool we will calculate with the following expression:

$$m_{sp}^* = m_{tool} + \frac{1}{3}m_{sp}, \quad (6)$$

where  $m_{tool}$  – weight of the tool;  $m_{sp}$  – weight of the machine spindle shaft

To find the corresponding derivatives from the expression of the kinetic energy, that belong to the left side of the Lagrange equations of the 2<sup>nd</sup> kind:

$$\begin{aligned} \frac{d}{dt} \left( \frac{\partial E_k}{\partial \dot{x}_1} \right) &= m_{sp} \cdot \ddot{x}_1; & \frac{d}{dt} \left( \frac{\partial E_k}{\partial \dot{x}_2} \right) &= m_{sp} \cdot \ddot{x}_2; \\ \frac{d}{dt} \left( \frac{\partial E_k}{\partial \dot{x}_3} \right) &= (m_{a.p.} + m_t) \cdot \ddot{x}_3; & \frac{d}{dt} \left( \frac{\partial E_k}{\partial \dot{x}_4} \right) &= (m_{a.p.} + m_t) \cdot \ddot{x}_4. \end{aligned} \quad (7)$$

Potential energy in the system is stored in the corresponding elastic elements. For its use of the following relationship:

$$E_n = c_1 \frac{x_1^2}{2} + c_2 \frac{x_2^2}{2} + c_5 \frac{(x_3 - x_1)^2}{2} + c_3 \frac{x_3^2}{2} + c_4 \frac{x_4^2}{2} \quad (8)$$

To find the corresponding derivatives from the expression of the potential energy, that belong to the left side of the Lagrange equations of the 2<sup>nd</sup> kind:

$$\begin{aligned} \frac{\partial E_p}{\partial x_1} &= c_1 \cdot x_1 - c_5 \cdot (x_3 - x_1); & \frac{\partial E_p}{\partial x_2} &= c_2 \cdot x_2; \\ \frac{\partial E_p}{\partial x_3} &= c_5 \cdot (x_3 - x_1) + c_3 \cdot x_3; & \frac{\partial E_p}{\partial x_4} &= c_4 \cdot x_4. \end{aligned} \quad (9)$$

Dissipative function  $\Phi$  for the system, assuming that the energy dissipation is directly proportional to the velocity, we will calculate with the following expression:

$$\Phi_d = k_1 \cdot \frac{\dot{x}_1^2}{2} + k_2 \cdot \frac{\dot{x}_2^2}{2} + k_5 \cdot \frac{(\dot{x}_3 - \dot{x}_1)^2}{2} + k_3 \cdot \frac{\dot{x}_3^2}{2} + k_4 \cdot \frac{\dot{x}_4^2}{2}, \quad (10)$$

where  $k_1$  – vertical spindle machine damping coefficient;  $k_2$  – horizontal spindle machine damping coefficient;  $k_3$  – vertical damping factor of the machine table;  $k_4$  – horizontal damping factor of the machine table;  $k_5$  – damping coefficient between tool and assembly part.

To find the corresponding derivatives from the expression of the dissipative function, that belong to the left side of the Lagrange equations of the 2<sup>nd</sup> kind:

$$\begin{aligned} \frac{\partial \Phi_d}{\partial \dot{x}_1} &= k_1 \cdot \dot{x}_1 - k_5 \cdot (\dot{x}_3 - \dot{x}_1); & \frac{\partial \Phi_d}{\partial \dot{x}_2} &= k_2 \cdot \dot{x}_2; \\ \frac{\partial \Phi_d}{\partial \dot{x}_3} &= k_5 \cdot \dot{x}_3 + k_5 \cdot (\dot{x}_3 - \dot{x}_1); & \frac{\partial \Phi_d}{\partial \dot{x}_4} &= k_4 \cdot \dot{x}_4 \end{aligned} \quad (11)$$

Mathematical model describing the dynamics of the mechanical system of the machine according to the equations (1), (3), (4), (7), (9), (11) will look like:

$$\begin{cases} \frac{d^2 \dot{x}_1}{dt^2} m_{sp}^* + c_1 \cdot x_1 - c_5 \cdot (x_3 - x_1) + k_1 \cdot \dot{x}_1 - k_5 \cdot (\dot{x}_3 - \dot{x}_1) = Q_1; \\ \frac{d^2 \dot{x}_2}{dt^2} m_{sp}^* + c_2 \cdot x_2 + k_2 \cdot \dot{x}_2 = Q_2; \\ \frac{d^2 \dot{x}_3}{dt^2} (m_{a.p.} + m_t) + c_5 \cdot (x_3 - x_1) + c_3 \cdot x_3 + k_3 \cdot \dot{x}_3 + k_5 \cdot (\dot{x}_3 - \dot{x}_1) = -Q_3; \\ \frac{d^2 \dot{x}_4}{dt^2} (m_{a.p.} + m_t) + c_4 \cdot x_4 + k_4 \cdot \dot{x}_4 = -Q_4. \end{cases} \quad (12)$$

The initial conditions:

$$\mathfrak{A}_1|_{t=0} = 0; \quad \mathfrak{A}_2|_{t=0} = 0; \quad \mathfrak{A}_3|_{t=0} = 0; \quad \mathfrak{A}_4|_{t=0} = 0;$$

$$x_1|_{t=0} = \frac{\Delta x \cdot \frac{c_1 \cdot c_3 \cdot c_5}{c_3 \cdot c_5 + c_1 \cdot c_5 + c_1 \cdot c_3}}{c_1}; \quad x_2|_{t=0} = 0;$$

$$x_3|_{t=0} = -\frac{\Delta x \cdot \frac{c_1 \cdot c_3 \cdot c_5}{c_3 \cdot c_5 + c_1 \cdot c_5 + c_1 \cdot c_3}}{c_3}; \quad x_4|_{t=0} = 0.$$

Additionally, we must enter the condition check availability contact (the contact stiffness and contact damping) due to the relative displacement of the tool and workpiece ie if  $x_1 - x_3 > 0$ , then  $c_5 = 0$ ,  $k_5 = 0$ .

The width of the groove on the working surface of the instrument affects the rise of arc. The wider the groove, the bigger the rise of arc will be. At low groove width the rise of arc is smaller. This will limit the movement of the processed surface while passing over the zone of contact between the tool and the assembly part on the working surface of the tool and unload the contact area. The unloaded processed surface under the influence of elastic deformation rises and will thrust against the edges of the groove. In this case, the shock load will not occur at a point that is on the normal to the processed surface, which is drawn through the axis of rotation of the tool, but a little sooner. The value of the rise of arc  $\Delta R$  (Fig. 4) is determined by the relationship:

$$\Delta R = R - R' = R - R \cdot \cos\left(\frac{j_s - j_g}{2}\right) = R \left(1 - \cos\left(\frac{p}{n}(1-k)\right)\right),$$

where  $k$  – ratio of the smooth part of the segment.

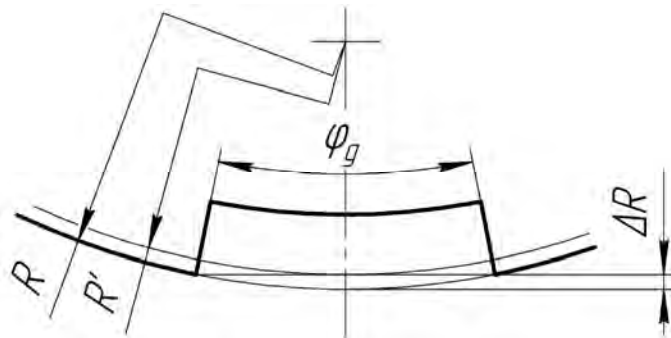

Fig. 4. Geometry of the groove

The initial displacement of the spindle (position of the instrument about parts (working surface)):

$$\Delta x = F \cdot c.$$

The initial pressing force of the spindle (working surface):

$$F = \Delta x \frac{c_1 \cdot c_3 \cdot c_5}{c_3 \cdot c_5 + c_1 \cdot c_5 + c_1 \cdot c_3}.$$

The initial pressing force of the spindle (groove):

$$F = (\Delta x - \Delta R) \cdot \frac{c_1 \cdot c_3 \cdot c_5}{c_3 \cdot c_5 + c_1 \cdot c_5 + c_1 \cdot c_3},$$

where  $F$  – pressing force of the tool to the machined surface of the workpiece.

**Conclusions.** A mathematical model for determination of dynamic parameters which occur during frictional hardening of flat surfaces of assembly parts of machines using a tool with a discontinuous working part has been received.

1. *Инженерия поверхности деталей / Под ред. А.Г. Сулова. – М. : Машиностроение, 2008. – 320 с.* 2. *Гурей І.В. Формування нанокристалічного зміцненого шару деталей машин під час*

*фрикційного зміцнення / І.В. Гурей, В.І. Гурей, П.Р. Дмитерко // Прогресивні технології і системи машинобудування. – 2013. – Вип. 1,2 (46) – С. 98–106. 3. Бать М.И. Теоретическая механика в примерах и задачах. Т. 3. Специальные главы механики / М.И. Бать, Г.Ю. Джанелидзе, А.С. Кельзон. – М.: Наука, 1973. – 488 с.*

УДК 621.833:666.94

А.О. Kychma, Ye.V. Kharchenko  
Lviv Polytechnic National University

## DETERMINATION OF VIBROPARAMETERS IN ELECTROMECHANICAL DRIVES WITH LARGE-SIZED OPEN GEARS

© Kychma A.O., Kharchenko Ye.V., 2014

**Запропонована математична модель для визначення перехідних режимів роботи обертових печей, сушильних барабанів і млинів з урахуванням електромагнітних процесів у асинхронному двигуні, механічних коливань елементів приводного механізму і довгомірної металоконструкції корпусу, а також зношення зубців відкритої зубчатої передачі. Наведено результати числових розрахунків.**

**A mathematical model of determining the transient regimes of operation of rotary furnaces, heating drums, and mills with taking into account electromagnetic processes in asynchronous motor, mechanical oscillations of elements of drive mechanism, and long-sized metal bodies, as well as wearing of the teeth of an open gearing is suggested. Results of numerical calculation are presented.**

**Introduction.** Electromechanical drives find their wide application in technological machines (heating drums, mills, rotary furnaces, and other analogues), which are complex systems with high vibroacoustic activity. In the general case, they can be considered as oscillation systems with accidental oscillations which are caused by impulsive force between two solids, as well as by periodical vibration which are caused by disbalance of rotating machine parts, ovality of shafts journals, variable rigidity, and form of involute profile of teeth of large-sized open gears and reduction gears. The control and removal of high vibration of driving mechanisms of such aggregates is a necessary condition of their effective operation, this facilitates the work of service personnel.

Practice of operating the driving mechanisms of rotary furnaces, mills, and heating drums shows that the assembly of open gearing of drive mechanisms is one of the least reliable links of such drives [1]. Problems of longevity of large-sized gearings of drive mechanisms of rotary furnaces, mills, and heating drums are considered in the works [2, 3]. In the course of operation of large-sized rotary furnaces, mills, and heating drums, the teeth of the open gears of the drive intensively wear because of specific condition of operation, which causes extra dynamic load in their meshing [4–6].

The main causes of excess vibration of aggregates are errors of manufacturing, inaccuracies of assembly of structural components, as well as intensive abrasive wearing of open gearings. Under a certain operating speed, the frequency of oscillations of forces of interaction between individual parts of the drive mechanism may coincide with the natural oscillation frequency of a machine of the considered type. The harmful influence of resonance phenomena which emerge in such case is described in the work [7].