

VOLTAGE CONTROL IN THE STATOR CIRCUIT OF CAGE INDUCTION MACHINE OPERATING AS GENERATOR IN SMALL SCALE HYDROPOWER PLANT

Andrzej Kandyba^{1,3}, Marian Kalus², Igor Piotr Kurytnik³

¹Department of Power Electronics, Electrical Drives and Robotics, Faculty of Electrical Engineering, Silesian University of Technology,

²Institute of Innovative Technologies Emag, Poland,

³Department of Electrical Engineering and Automation University of Bielsko-Biala
ikurytnik@ath.bielsko.pl

Abstract: The synthesis of RMS voltage control system in the stator circuit of squirrel cage induction machine based on the linear criterion of " optimum magnitude" by C. Kessler 'a was performed. The squirrel cage induction machine was operating as a generator in autonomous (isolated) network. Induction machine is driven by an induction machine supplied from the inverter, which simulates the low pressure head water turbine. Synthesis process of the control system was supported by experimental studies of this system.

Key words: Small hydroelectric power plant, asynchronous generator, isolated grid, control system.

1. Introduction

Three-phase induction machine is a electromechanical transducer and as such may operate either as motor or as generator. When machine is connected to the grid, change of operation mode may be achieved by varying its rotational speed. If machine is to operate as a generator in isolated grid, additional conditions must be met [4, 5]. Proper excitation of the machine is the crucial requirement if machine is to operate within a isolated grid (for instance in small hydro-electric power plant). Variable magnetic field may be generated by a capacitor bank connected in parallel to the stator windings. The machine will generate electrical energy, if self-excitation condition is fulfilled. This condition relates capacitor's capacitances to asynchronous machine (MA) parameters in the initial stages of core saturation [1,2,3]:

$$C \geq \frac{1}{2\pi f (X_s + X_\mu)} \quad (1)$$

where: X_μ – magnetizing reactance of asynchronous generator, X_s – asynchronous generator leakage reactance, f – frequency of generated voltage. In order to initialize self-excitation process, additional provisions must exist, i.e. magnetic remanence in the machine must be present. It is essential that the slope of initial part of voltage-current curve in no-load operation $U_1=f_1(I_0)$ is situated above the curve of capacitor bank $U_C=f_2(I_0)$.

2. Conception of rms voltage control in stator circuit of slip-ring asynchronous machine (MAP) operating as generator and driven with cage induction machine (MAK) supplied via frequency converter and simulating a water turbine

Scheme of rms voltage control circuit in MAP stator of machine operating as generator connected to isolated grid, driven with cage asynchronous machine supplied via frequency converter and simulating a water turbine is shown in Figure 1 [4, 5]. This scheme has been designed basing on standard control theory. Rms voltage in MAP stator circuit of machine connected to isolated grid is the controlled quantity in discussed control circuit. The principle of operation of rms voltage control circuit in MAP stator circuit is based on controlling voltage and frequency in frequency converter supplying MIK machine (which simulates a water turbine).

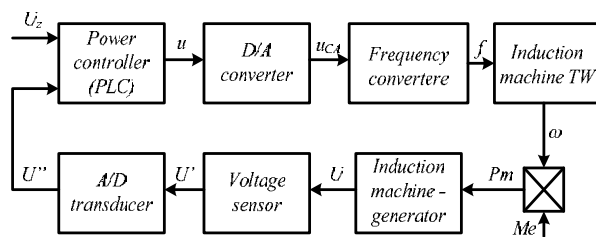

Fig. 1. Schematic diagram of voltage control system in MAP stator circuit; MAP operates as generator and is driven with cage asynchronous machine supplied via frequency converter and simulating a water turbine

Following designations are used: U_z – set rms voltage, bit; U'' – signal obtained at the output of A/D converter PAC, bit; U' – signal proportional to real value of rms voltage obtained at the output of power measurement sensor, mA; U – real value of rms voltage, V; u – control signal obtained at output of voltage controller (PLC), bit; u_{CA} – control signal obtained at output of D/A converter (PAC), mA; f – output frequency of frequency converter, Hz; ω – angular speed

of induction machine simulating a water turbine, rad/s; Me – electromagnetic torque at shaft of induction machine simulating a water turbine. If control algorithm $U/f=\text{const}$ is used, $Me = \text{const}$, electromagnetic torque, Nm, P_m – power at shaft of induction motor simulating a water turbine, W.

3. RMS voltage control circuit in MAP stator circuit

The block diagram of rms voltage control circuit in MAP stator circuit of machine operating as a generator connected to isolated grid and driven with MIK supplied via frequency converter is shown in Figure 2. The diagram has been constructed on the basis of schematic diagram shown in Figure 1.

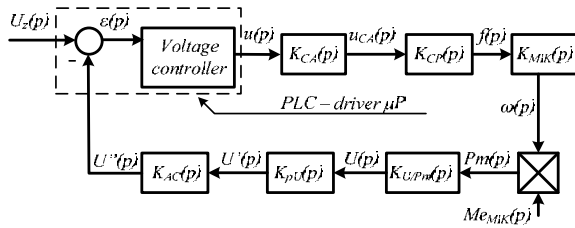

Fig. 2. Block diagram of active power control circuit in stator circuit of slip-ring asynchronous machine operating as generator connected to isolated grid, driven with cage induction motor supplied via frequency converter and simulating a water turbine

Following designations have been introduced in Figure 2:

$U_z'(p)$ – set rms voltage, bit; $\varepsilon(p)$ – comparison error, bit; $u(p)$ – output (control) signal from voltage controller (PLC), bit;

$u_{CA}(p)$ – output signal from PCA, mA;

$K_{CA}(p)$ –Laplacian transfer function for PCA, bit/mA:

$$K_{CA}(p) = \frac{u_{CA}(p)}{u(p)} = \frac{u_{CA\max}}{u_{\max}} \quad (2)$$

$K_{PC}(p)$ – Laplacian transfer function for inverter, Hz/mA:

$$K_{PC}(p) = \frac{f(p)}{u_{CA}(p)} = \frac{f_{\max}}{u_{CA\max}} \quad (3)$$

$K_{MIK}(p)$ – Laplacian transfer function for MIK (machine simulating a water turbine), rad/Hz•s:

$$K_{MIK}(p) = \frac{\omega(p)}{f(p)} = \frac{\frac{\omega_{\max}}{f_{\max}}}{1 + p \cdot T_{MIK}} \quad (4)$$

where: T_{MIK} – mechanical time constant related to inertia of induction machine simulating a water turbine and asynchronous machine operating as generator (in seconds), hence:

$$T_{MIK} = \frac{(J_{MIK} + J_{MAK}) \cdot \Omega_b^2}{p_b^2 \cdot S_N} = \frac{2 \cdot \pi \cdot (J_{MIK} + J_{MAK}) \cdot f_N}{3 \cdot p_b^2 \cdot U_{SKN} \cdot I_{SKN}} \quad (5)$$

where: J_{MIK} – moment of inertia of cage induction machine simulating a water turbine, kgm^2 ; J_{MAK} – moment of inertia of asynchronous machine operating as generator, kgm^2 ; f_N – rated frequency of MIK, simulating a water turbine, Hz; p_b – number of pole pairs of cage induction machine, simulating a water turbine, dimensionless quantity; U_{SKN} – rated MIK rms phase voltage, V; I_{SKN} – rated MIK rms phase current, in A; $Me_{MIK}(p)$ – electromagnetic torque at shaft, Nm; $P_m(p)$ – MIK power at shaft, W; $K_{U/Pm}(p)$ – Laplacian transfer function relating rms voltage in MAP stator (machine operating as generator) to power at shaft of the same machine, V/W:

$$K_{U/Pm}(p) = \frac{\Delta U(p)}{\Delta P_m(p)} = \frac{\frac{\Delta U}{\Delta P_m}}{1 + p \cdot T_{U/Pm}} \quad (6)$$

where: $T_{U/Pm}$ – time constant related to the process of generating rms voltage vs. MIK power at shaft (MIK – machine simulating a water turbine), s; $U(p)$ – real value of rms voltage in MAP stator circuit (machine operating as generator), V; $K_{PU}(p)$ – transfer function of rms voltage measurement sensor, mA/V

$$K_{PU}(p) = \frac{U'(p)}{U(p)} = \frac{U'_{\max}}{U_{\max}} \quad (7)$$

where: $U'(p) = U'_{\max}$ – signal obtained at the output of measurement transducer, proportional to real value of voltage $U(p)$, mA;

$K_{CA}(p)$ – PAC transfer function, bit/mA:

$$K_{AC}(p) = \frac{U''(p)}{U'(p)} = \frac{U''_{\max}}{U'_{\max}} \quad (8)$$

and $U''(p)$ – PAC input signal, bit.

4. Selection of structure of rms voltage controller operating in MAP stator circuit

Synthesis of control system of MAP stator rms voltage, where MAP operates as generator connected to isolated grid and is driven with MIK machine supplied via frequency converter and simulating a small water turbine, has been conducted basing on “optimum magnitude” criterion suggested by C. Kessler. Starting point for the synthesis based on this criterion is transmittance (transfer function) of open-loop control system (without controller), obtained with block diagram shown in Figure 3 [1.3.5].

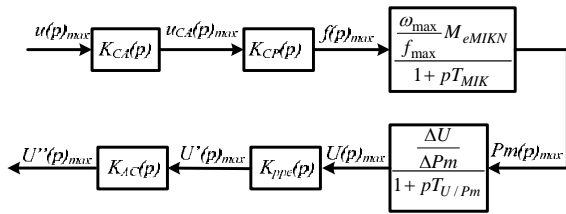

Fig. 3. Block diagram of open-loop MAP stator rms voltage control system; MAP machine operates as generator within isolated grid and is driven with MIK machine supplied via frequency converter and simulating a water turbine

Open-loop control system transfer function obtained on the basis of block diagram presented above may be defined as:

$$K_o(p) = \frac{K_{CA} \cdot K_{PC} \cdot \frac{\omega_{max}}{f_{max}} \cdot M_{eMIKN} \cdot \frac{\Delta U}{\Delta P_m} \cdot K_{pU} \cdot K_{AC}}{(1 + p \cdot T_{MIK}) \cdot (1 + p \cdot T_{U/P_m})} \quad (9)$$

Basing on Kessler's "Optimum magnitude" criterion, PI voltage controller was adopted. Parameters of this structure may be described by following relationships:

integral time of I element:

$$T_Z = T_{MIK} \quad (10)$$

gain coefficient of P element:

$$K_P = \frac{T_{MIK}}{2 \cdot K_o \cdot T_{U/P_m}} \quad (11)$$

where:

$$K_o = K_{CA} \cdot K_{PC} \cdot \frac{\omega_{max}}{f_{max}} \cdot M_{eMIKN} \cdot \frac{\Delta U}{\Delta P_m} \cdot K_{pU} \cdot K_{AC} \quad (12)$$

and finally:

$$K_P = \frac{T_{MIK} \cdot f_{max}}{2 T_{U/P_m} K_{CA} K_{PC} \omega_{max} M_{eMIKN} \frac{\Delta U}{\Delta P_m} K_{pU} K_{AC}} \quad (13)$$

Experimental tests of small hydro-electric power plant MEW operating within isolated grid

Schematic diagram of MEW operating within isolated grid, and simulated by MIK supplied from frequency converter, running on common shaft with slip-ring induction machine with short-circuited rotor, is shown in Figure 4. MEW turbine is simulated by voltage frequency converter *FNI* together with *MIK*. Role of cage asynchronous generator operating within isolated grid *SW* is played by slip-ring asynchronous machine *MAP*, with short-circuited rotor windings and commutation capacitors *CI - C3* connected to the stator windings. Control and protection processes within the small hydro-electric power plant structure are carried out in control and protection circuits with the help of

software implemented in microprocessor driver *SμP*. In particular, the control and protection system in question fulfils following functions:

Ensures automatic start-up of MEW connected to isolated grid;

Assures stabilisation of rms voltage in isolated grid in accordance with set value;

Ensures failure-free operation of over-speeding protection of small hydro-electric power plant (over-speeding caused by e.g. load decay of low-speed slip-ring induction machine with rotor windings short-circuited);

Ensures failure-free operation of short-circuit protection in stator circuit of low-speed slip-ring induction machine with rotor windings short-circuited;

Ensures failure-free operation of overvoltage protection in stator circuit of low-speed slip-ring induction machine with rotor windings short-circuited.

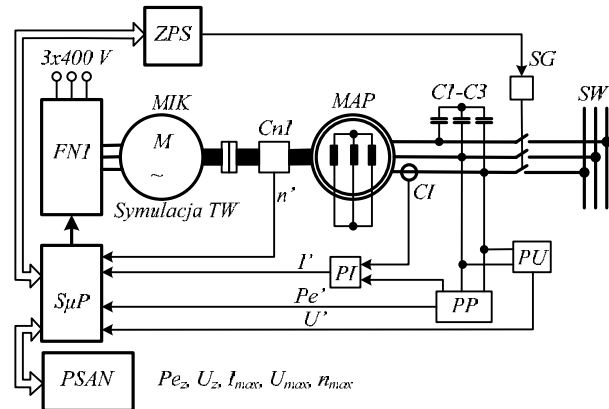

Fig. 4. Laboratory model of small hydro-electric power plant, connected to isolated grid and simulated by cage induction motor supplied from frequency converter and mounted on common shaft with slip-ring induction machine having rotor windings short-circuited.

The following designations are adopted here: *MIK* – cage induction machine, simulating a water turbine, *FNI* – voltage inverter; *SμP* – microprocessor driver; *Cn1* – slip-ring asynchronous machine rotational speed sensor; *MAP* – slip-ring asynchronous machine operating with short-circuited rotor windings; *CI* – current sensor (current transformer) in stator phase winding; *I* – signal proportional to real (instantaneous) current value, stator W phase; *PI* – current transducer (real value *I* to standardized value 4 ... 20 mA); *PU* – voltage transducer (real value *U* to standardized value 4 ... 20 mA); *PP* – three-phase power transducer (real value *Pe* to standardized value 4 ... 20 mA); *Pe'* – electric power transferred from slip-ring asynchronous machine stator to isolated grid circuit *W*; *n'* – standardized rotational speed signal 4 ... 20 mA; *I'* – standardized current signal 4 ... 20 mA; *U'* – standardized voltage signal 4 ... 20 mA;

Pe' – standardized three-phase power signal 4 ... 20 mA; SG – main contactor; SW – isolated grid; ZPS – relay-contactor unit; $PSAN$ – Alpha Numeric control panel; Pe_z – set value of electrical power (option), W; U_z – set value of rms voltage (phase-to-phase) in stator circuit (option), V; I_{max} – maximum value of rms stator current value, A; U_{max} – maximum value of rms phase-to-phase voltage in stator circuit, V; n_{max} – maximum value of rotational speed of slip-ring asynchronous machine rpm $C1 - C3$ – commutation capacitors in slip-ring asynchronous machine stator circuit.

Experimental tests have been conducted for system consisting of following elements:

Voltage frequency converter FNI : type ESMD752L4TXA, rated power 7.5 kW; supply 3x400 V, rated frequency 50 Hz; rated current 14.0 A;

Cage induction machine MIK simulating a water turbine: type DM1 160 M 6; rated power 7.5 kW; supply 3x400 V, rated frequency 50 Hz; rated speed 965rpm; rated power factor: 0.8; efficiency at rated load 85.2 %;

Rotational speed sensor $Cn1$ of slip-ring asynchronous machine operating with rotor windings short-circuited, range 0... 99999 rpm output signal 4 ... 20 mA; transducer fitted with display;

Slip-ring asynchronous machine MAP , operating with rotor windings short-circuited: type SUDg 160 L-8; rated voltage U_N 3 x 380 V; rated power P_N 7.5 kW; rated speed at rated load, for motor mode n_N 955 rpm efficiency η_N : 86.4 %; power factor 0.69 (dimensionless quantity); rated current (rms) I_{SN} 19.1 A; rated electromagnetic torque at shaft M_{eN} 75 Nm; moment of inertia J 0.105 kgm²; number of pole pairs $p=3$;

Current transformer CI in stator A phase, type WSK 60;: rated primary current 15 A; rated secondary current 1 A; accuracy class 0,5 %; rated power 10 VA;

Current transducer PI (real value I to standardized value 4 ... 20 mA); input range 0 – 1 A; output range 4 ... 20 mA;

Voltage transducer PU (real value U to standardized value 4 ... 20 mA); input range 0 – 400 V; output range 4 ... 20 mA;

Microprocessor driver $S\mu P$ with following components: central processing unit CPU 226 for S7-200 driver, with ratings: memory 8 kBytes; supply voltage DC-24 V; digital inputs module EM 221 for S7-200 driver, with ratings: number of digital inputs 8; type supply voltage of digital inputs DC-24 V; I/O module, analog, EM 235 for S7-200 driver, with ratings: number of analog inputs 4; number of analog outputs 1; processing resolution 12 bit; Analog input module EM 232 for S7-200 driver, with ratings: number of analog inputs 2; resolution 12 bit; Digital outputs module EM 222 for S7-200 driver, with ratings: number of digital inputs 8;

type of digital outputs supply voltage DC-24 V; type EM 222; number: 2; Alpha Numeric control panel OP15;

Commutation capacitors $C1 - C3$ 280 μF ;

Isolated grid (SW) load: 3x100 Ω ;

Rms voltage PI controller parameters: integral time $T_z = T_{MIK}$: 1.32 s; proportional gain K_p : 7.3.

Fig. 5 shows part of the test stand (photo).

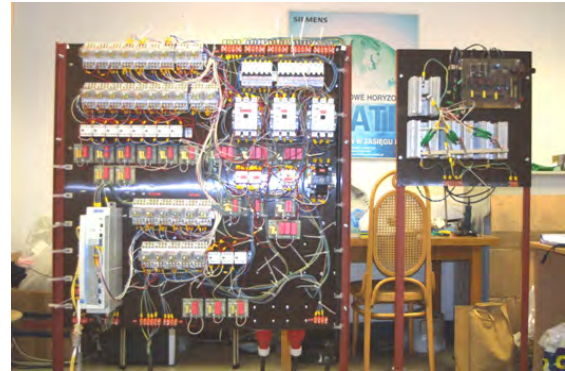

Fig. 5. Control panel and frequency converter – test stand

Fig.6 presents waveforms of MAP output voltage (real) U and rotational speed n , generated in response to change in set voltage U_z .

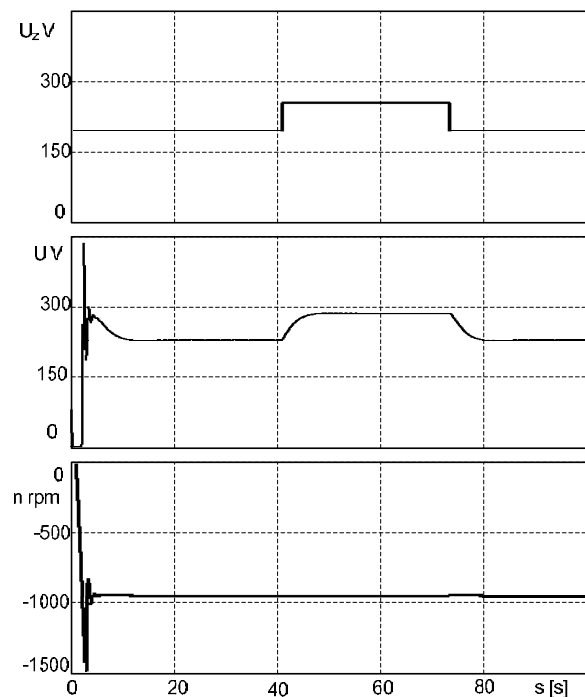

Fig. 6. Output voltage U and speed n waveforms in closed-loop control system NMAK as response to change in set voltage U_z

7. Conclusion

Synthesis of voltage control system for slip-ring asynchronous machine stator has been conducted. This machine operates with rotor windings short-circuited, is driven with cage induction motor supplied via frequency

converter and simulating a water turbine, and is connected as generator to isolated grid. The control system is based on linear “optimum magnitude” criterion as formulated by C. Kessler.

Experimental tests of rms voltage control system for stator circuit of slip-ring asynchronous machine with rotor windings short-circuited, driven with cage induction motor supplied via frequency converter and simulating a water turbine, connected as generator to isolated grid have been run.

The experiments were aimed at determining the following waveforms: real rms voltage in stator circuit of slip-ring asynchronous machine with short-circuited rotor windings and real rotational speed of this machine, operating as generator connected to isolated grid. These waveforms were found for closed-loop control system as response to change in set rms voltage value.

The following conclusions have been drawn on the basis of conducted experiments:

Selection of structure and tuning of parameters for rms voltage controller operating in stator circuit of slip-ring asynchronous machine with short-circuited rotor windings, on the basis of linear “Magnitude optimum” criterion as suggested by C. Kessler, have made it possible to attain good dynamics (with minimum overshoot) of rms voltage waveform obtained as a response to unit step change in rms voltage;

Current and voltage frequency as well as rotational speed of slip-ring asynchronous machine operating as generator connected to isolated grid are constant versus such quantities as: shaft torque of cage induction machine simulating a water turbine, electromagnetic torque, magnitudes of voltages and currents in slip-ring machine circuit and power output to isolated grid. However, they strongly depend on the capacitance of three-phase commutation capacitor connected into the stator and on equivalent scheme parameters of slip-ring asynchronous machine with rotor windings short-circuited.

Reference

1 Orlewski W. Elektryczne charakterystyki generatora asynchronicznego pracującego samodzielnie w instalacji biogazowej // Proceedings of Conference: VII Ogólnopolskie Forum Odnawialnych Źródeł Energii. Międzybrodzie Żywieckie, Poland. – 2002.

2 Kasprowicz A. Sterowanie samowzбудnym generatorem indukcyjnym // Przegląd Elektrotechniczny – 2008. –No. 11. –P. 334 – 339. [Pol]

3 Andreica M.; Bacha S. Roye D.; Exteberria-Otaui I.; Munteanu I.; Micro-hydro water current turbine control for grid connected or islanding operation

// Power Electronics Specialists Conference. – 2008. PESC 2008. IEEE. P. 957 – 962.

4 Hickiewicz J. Moch J. Pomiarowa ocena maszyny indukcyjnej pracującej jako generator w małej elektrowni wodnej Wiadomości Elektrotechniczne. – 2005. – No. 12 – P.14-16.[Pol]

5 Kandyba A. Kalus M. Kurytnik I.P. Synthesis and simulation of stator rms voltage control circuit of cage induction machine operating as generator in small hydropower plant supplying off-grid customers // Przegląd Elektrotechniczny. – 2012. –№. 6. –P. 138–141.

РЕГУЛЮВАННЯ НАПРУГИ В КОЛІ СТАТОРА АСИНХРОННОЇ МАШИНИ З КОРОТКОЗАМКНЕНИМ РОТОРОМ, ЩО ПРАЦЮЄ В РЕЖИМІ ГЕНЕРАТОРА МАЛОЇ ГІДРОЕЛЕКТРОСТАНЦІ

А. Кандиба, М. Калюс,
І.-П. Куритнік

За лінійним критерієм модульного оптимуму (за Кесслером) синтезовано регулятор діючої напруги статора асинхронної машини з короткозамкненим ротором. Асинхронна машина з короткозамкненим ротором працює в режимі генератора в автономній мережі. Асинхронний генератор приводиться в рух асинхронним двигуном, що живиться від інвертора, для імітації гідротурбіни низького тиску. Адекватність отриманих результатів підтверджено експериментом.



Andrzej Kandyba – Ph.D.

Research and academic worker in the Department of Power Electronics, Electrical Drives and Robotics. His interests concern on power electronic supply systems for electrical drives and electrothermal devices, especially on plasma devices and power electronic converters applied in

renewable energy systems using wind, water and solar energy.



Igor Piotr Kurytnik – Prof. dr hab. inż is a graduate of the Politechnika Lwowska. Head of Electrical Engineering and Automation department at University of Bielsko-Biala (Poland). Author of 300 patents, standards, books, technical scientific papers, range from automation, telecommunication, information and measuring techniques.

The member of Engineering Academy in Poland and Scientific Engineering Academy in Ukraine.