

Scanning Television Optical Microscope with Illumination of Microobject in a Ultra-Violet Range

Yurij Balanjuk, Yurij Matiieshyn, Anatoliy Pedan

Abstract – Ways of construction of a scanning television optical microscope with use of an electron beam tube of a ultra-violet range of radiation, suitable for research of various biological microobjects are analyzed. The block diagram of a microscope is offered from the point of view of program-algorithmic maintenance of its work.

Key words – Scanning television optical microscope, Ultra-violet microscopy, Microobject.

I. INTRODUCTION

The task of formation of the image in a seen range of a spectrum at illumination of microobject (MO) in ultra-violet (UV) range is enough actual for modern microscopy. Use in classical optical UV microscope instead of an irradiator on a mercury lamp of a high pressure of the scanner on projective electron beam tube (EBT) of high resolution with the monocrystal luminescent screen allows to form scanning raster in the television standard of the image [1].

II. SCANNING TELEVISION OPTICAL MICROSCOPE ON THE BASIS OF ULTRA-VIOLET EBT

The block diagram of scanning television optical microscope (STOM) with use of the EBT of UV range of radiation is submitted on fig. 1.

Into its structure enter: the block of formation of scanning raster BFSR, the block of management of operating modes of scanning electron beam tube BMOM, the block of an electron beam tube of high resolution with a ultra-violet luminescence of screen BEBT, the block of the optical channel BOCH, the block of photoelectronic multiplier BPEM, the block of formation of video signal BFVS, the block of processing of video signal BPVS, the block of interface to personal computer BIPC, a personal computer PC and the monitor M on which screen the image of researched MO which is scanned in a ultra-violet range is formed.

Use of the UV STOM for research various biological and medical MO has a number of advantages before other types of microscopes:

- higher resolution due to smaller length of a wave;
- an opportunity of research MO in UV range of illumination;
- an opportunity of reception of a secondary luminescence at UV illumination of researched MO;

Yurij Balanjuk, Yurij Matiieshyn, Anatoliy Pedan – Polytechnic National University, S. Bandery Str., 12, Lviv, 79013, UKRAINE, E-mail: shkliarskyi @ polynet. lviv.ua

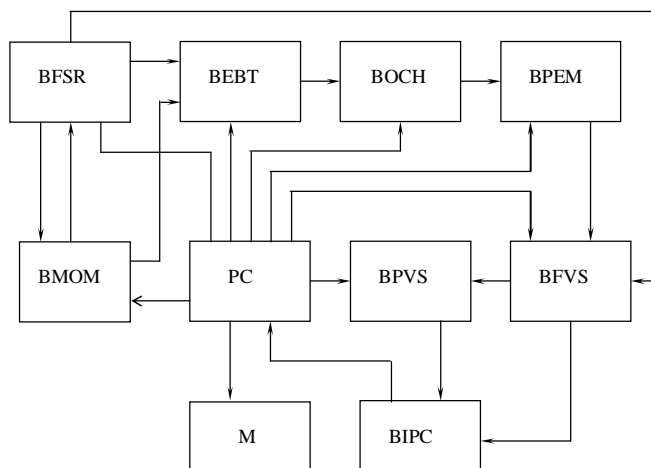

Fig.1. Block diagram of the UV STOM for research of biological MO

- an opportunity of reception of researched MO images in pseudo-colors at UV illumination of researched MO;
- an opportunity of reception of seen images at UV illumination of researched MO;
- extremely low power of illumination of researched MO, that allows to carry out their researches without drawing harm (power of illumination in millions times below than, for example, in laser microscopy).

III. CONCLUSIONS

Use in STOM an electron beam tube for illumination of microobjects in a ultra-violet range of radiation will essentially expand measuring and functionalities at research of biological microobjects in real time in medical and biological establishments in comparison with usual television microscopes.

REFERENCES

- [1] Pedan A.D. Research of a relief of biological microobjects surface in a ultra-violet scanning television-optical microscope / A. D. Pedan, B. I. Lubinecka // Visnik of the National university "Lvivska Polytechnica" – "Radioelectronics and telecommunications". – 2011. – № 705. – P. 84-89 (In Ukrainian).